

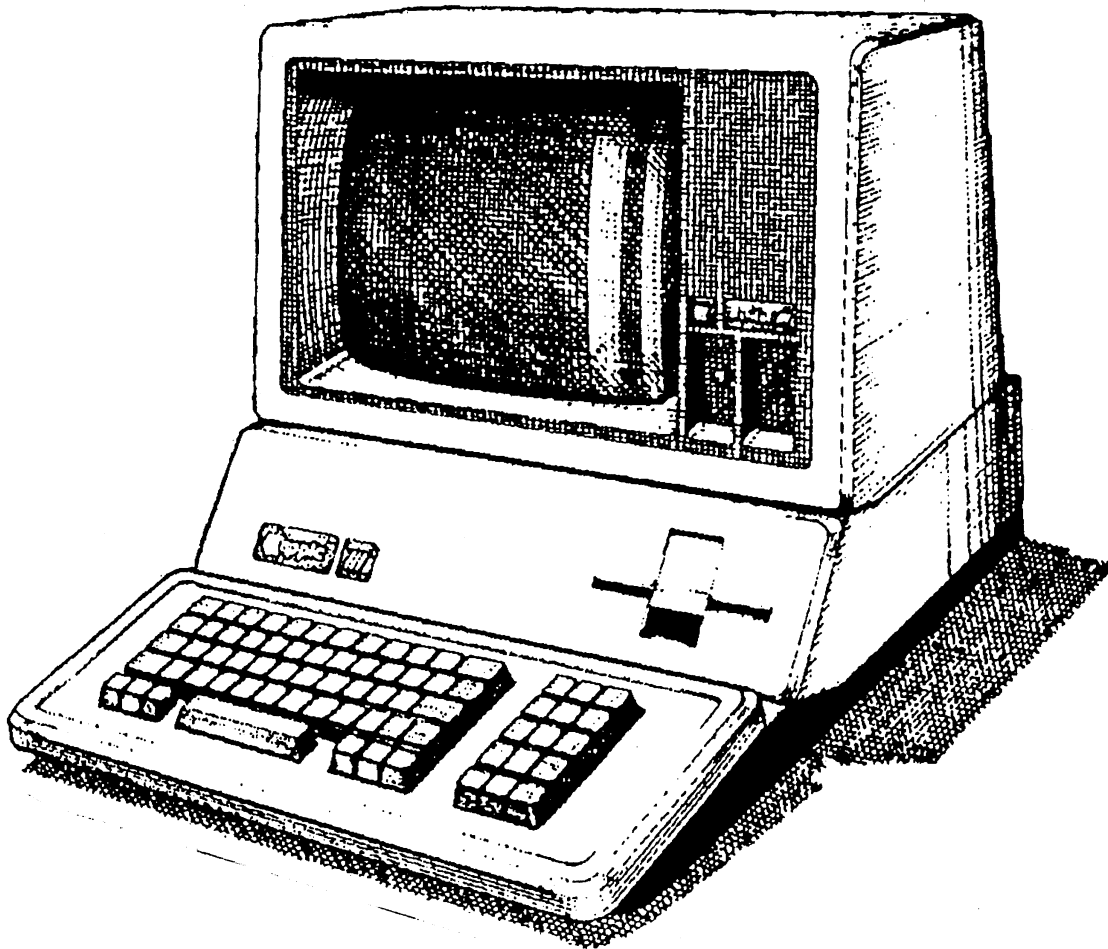

Apple III Computer Information



DOCUMENT NAME		#
<i>Repair Info:</i>	<i>Apple</i>	227
<i>Apple III and III Plus Computer</i>	<i>Sep. 1988</i>	

Ex Libris David T. Craig

🍏 **Apple Technical Procedures**

Apple III/III Plus

Technical Procedures

□ TABLE OF CONTENTS

Section 0 – Service Notes	0.4	Memory and Logic Board Exchanges
	0.4	Automatic Upgrades
	0.4	Returning Logic Boards: Removing Video Interlace ROM
	0.4	Installing Logic Boards: Removing Foam
	0.4	Power Supply Cables
Section 1 – Take-Apart	1.3	Removing the Cover
	1.3	Replacing the Cover
	1.5	Removing the Analog Board
	1.7	Replacing the Analog Board
	1.9	Removing the Disk Assembly
	1.9	Replacing the Disk Assembly
	1.11	Removing the Keyboard
	1.11	Replacing the Keyboard
	1.13	Removing the Power Supply
	1.13	Replacing the Power Supply
Section 2 – Diagnostics (Apple III Only)	2.3	Diagnostics Setup
	2.3	Diagnostics Menu
	2.4	Making Test Diskettes
	2.5	Test All
	2.5	Video Tests
	2.7	Sound Tests
	2.7	Disk Test
	2.8	Keyboard Tests
	2.9	ROM Test
Section 3 – Troubleshooting	3.3	Using the Diagnostic Flowchart
	3.4	Lettered Boxes of the Flowchart
	3.9	ProFile Problems with the Apple III

Section 4 – Modifications	4.2	Installing the Apple III Clock Kit
	4.4	Setting the Apple III Clock
	4.6	Adjusting the Apple III Clock Speed
	4.10	256K RAM Upgrade
	4.12	Apple III Keyboard Replacement

Section 5 – Diagnostics (Apple III Plus Only)	5.3	Introduction
	5.3	Diagnostics Setup
	5.3	Diagnostics Menu
	5.4	Make Test Disks (Diskettes)
	5.5	RAM Test
	5.6	ROM Test
	5.6	Calender/Clock Test
	5.6	Disk Test
	5.7	Keyboard Tests
	5.9	Sound Tests
5.10	Video Tests	
5.13	Test All	

Section 6 – Illustrated Parts List	6.3	Finished Goods Assembly
	6.5	Universal Parallel Printer Boards
	6.5	Logic Board
	6.5	Memory Board

Appendix A	A.1	Apple III Keyboard/Keyswitch Identification
-------------------	-----	---------------------------------------------

Note: These Technical Procedures apply to both the Apple III and Apple III Plus (unless otherwise noted).

©Apple Computer, Inc., 1982-1988. No portion of this document may be reproduced in any form without the written permission of Apple Computer, Inc.

Apple and the Apple logo are registered trademarks of Apple Computer, Inc.

Apple /// Technical Procedures

Section 0

Apple /// Service Notes

Contents:

Memory and Logic Board Exchanges
 Automatic Upgrades..... 0.4
 Returning Logic Boards: Removing Video Interlace ROM....0.4
 Installing Logic Boards: Removing Foam.....0.4
Power Supply Cables.....0.4

APPLE /// MEMORY AND LOGIC BOARD EXCHANGES

Automatic Upgrades

The 256K 5V Memory Board and the 5V Apple /// Logic Board are the only modules now available from Apple for purchase or exchange.

Because of this:

- All Apple 12V systems and 128K 5V systems will be upgraded to 256K 5V systems for a nominal charge when a Memory Board or a 12V Logic Board fails.
- If one board in a 12V system fails, both boards (Logic and Memory) will have to be replaced.

IMPORTANT: All 5V Memory Boards are to be returned WITH RAM. The exchange modules come fully stuffed with 256K of RAM.

Returning Logic Boards: Removing Video Interlace ROM

Before returning an Apple /// Logic Board for exchange, you must remove and keep the video interlace ROM (if present). The ROM (P/N 342-0145) is at location F5 on the Logic Board. The exchange board will not include this ROM.

Installing Logic Boards: Removing Foam

The Apple /// Logic Board is shipped with a piece of black foam taped to the bottom of the board to protect the encoder chip. Be sure to remove the black foam before installing the Logic Board. Failure to do so can cause damage to the encoder chip and/or the Logic Board.

POWER SUPPLY CABLES

There are two types of power supply cable connectors: one has two rows of four pins, and the other has one row of ten pins. Check which type of connector is on the logic board before ordering the cable. The one row with ten pins requires the part listed as **Cable, Power Supply to Apple /// Logic Board**. The two rows with four pins requires the part listed as **Cable, Power Supply RFI Apple /// Plus**.

Apple /// Technical Procedures

Section 1

Take-Apart

Contents:

Removing the Cover.....1.3
Replacing the Cover.....1.3
Removing the Analog Board.....1.5
Replacing the Analog Board.....1.7
Removing the Disk Assembly.....1.9
Replacing the Disk Assembly.....1.9
Removing the Keyboard.....1.11
Replacing the Keyboard.....1.11
Removing the Power Supply.....1.13
Replacing the Power Supply.....1.13
Removing the Main Logic Assembly.....1.15
Replacing the Main Logic Assembly.....1.17

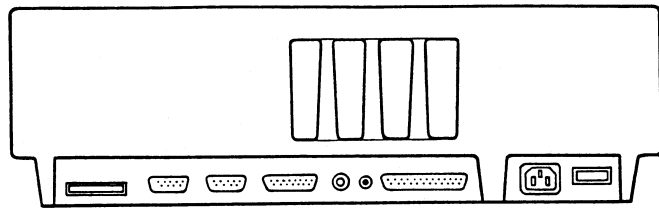

FIGURE 1

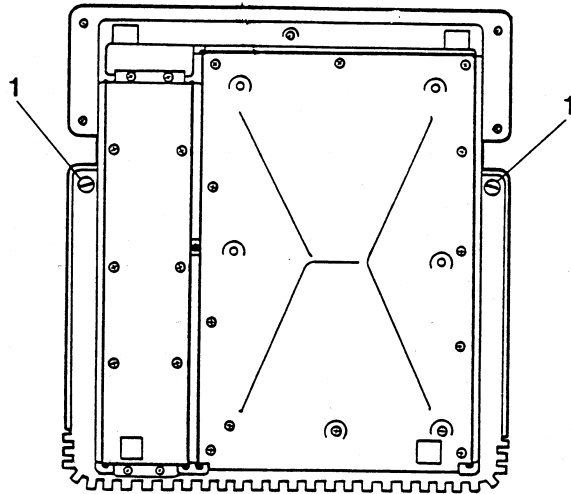

FIGURE 2

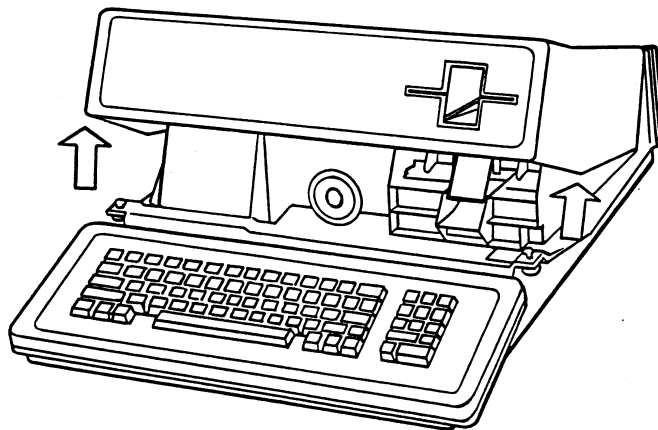

FIGURE 3

A. REMOVING THE COVER

1. Power down and disconnect the AC power cord from the source and then from the back of the Apple ///.
2. Disconnect all other external cables from the back of the Apple ///. (See Figure 1).
3. Lift up the front edge of the Apple and tip it up so it rests on the back of the casing.
4. Use a flat blade screwdriver to turn the locking screws, one on each side of the Apple III, 1/4 turn counterclockwise. (See Figure 2, Item 1).

DO NOT REMOVE THESE SCREWS--they are self-capturing and are supposed to stay in.

5. Lower the Apple /// to the operating position and with a hand on each side, lift the cover up and pull it forward to remove it. (See Figure 3).

B. REPLACING THE COVER

1. With the Apple /// in operating position, place the cover on making sure that it is seated properly all the way around. Be sure that the four tabs on the back of the cover fit into the four slots in the back of the Apple.
2. Tip up the front edge of the Apple and tighten the two locking screws by turning them 1/4 turn clockwise.

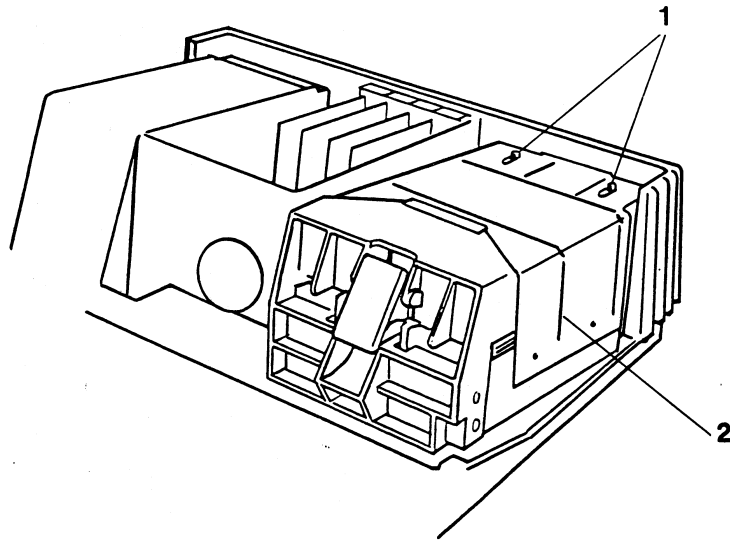

FIGURE 4

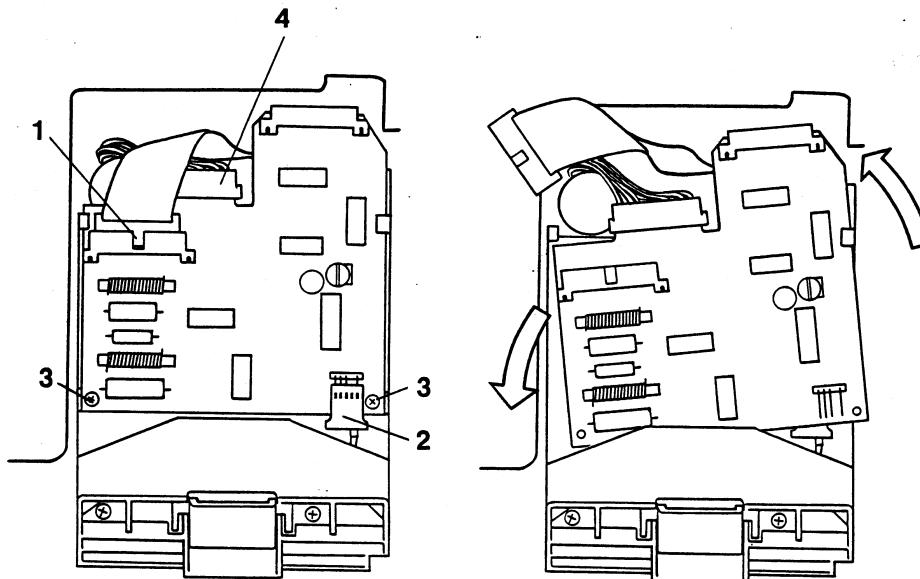

FIGURE 5

FIGURE 6

C. REMOVING THE ANALOG BOARD

1. Remove the cover.
2. To get to the analog board you must first remove the disk assembly shield. To do this, use a flat blade screwdriver to slide the two Tinnerman retaining clips on the disk assembly shield forward. (See Figure 4, Item 1).

NOTE: The clips should come off easily. However, they sometimes fly so you should keep a finger on them.

3. Remove the disk assembly shield by flexing the side out (See Figure 4, Item 2) and lifting up on the shield.

The shield is only retained by the spring tension of the sides and four dimples which fit into depressions of the disk casting.

4. Disconnect the disk ribbon cable. If it is hard to remove, work it off by pushing on the center tab or the sides of the plug with a small screwdriver. DO NOT PULL IT OUT BY THE CABLE! (See Figure 5, Item 1).
5. Disconnect the read/write head cable. (See Figure 5, Item 2).

NOTE: Do not try to remove the motor control cable yet. (see Figure 5, item 4).

6. Remove the two small Phillips head mounting screws which hold the analog board at the front of the casting. (See Figure 5, Item 3).
7. Remove the analog board by gently twisting it counterclockwise and moving it forward until it clears the guide on the left. Unhook it from the guide on the right. (See Figure 6).
8. Remove the motor control plug (Figure 5, Item 4) by disengaging the four nylon locking pawls which engage the two holes in the board from both top and bottom. Lift the pawls free and disconnect the motor control cable.

P. 1.6 blank

D. REPLACING THE ANALOG BOARD

1. Connect the motor plug. Make sure the nylon pawls are engaged in the holes.
2. Turn the board slightly counterclockwise and hook the board under the right retainer and then the left retainer.
3. Replace the two screws in front.
4. Replace the disk ribbon cable.
5. Replace the read/write head cable.
6. Replace the disk assembly shield.
7. Replace the Tinnerman clips by putting them over the posts and sliding them back. Use a screwdriver to press down firmly on the sides of the clips to secure them.
8. Replace the cover.

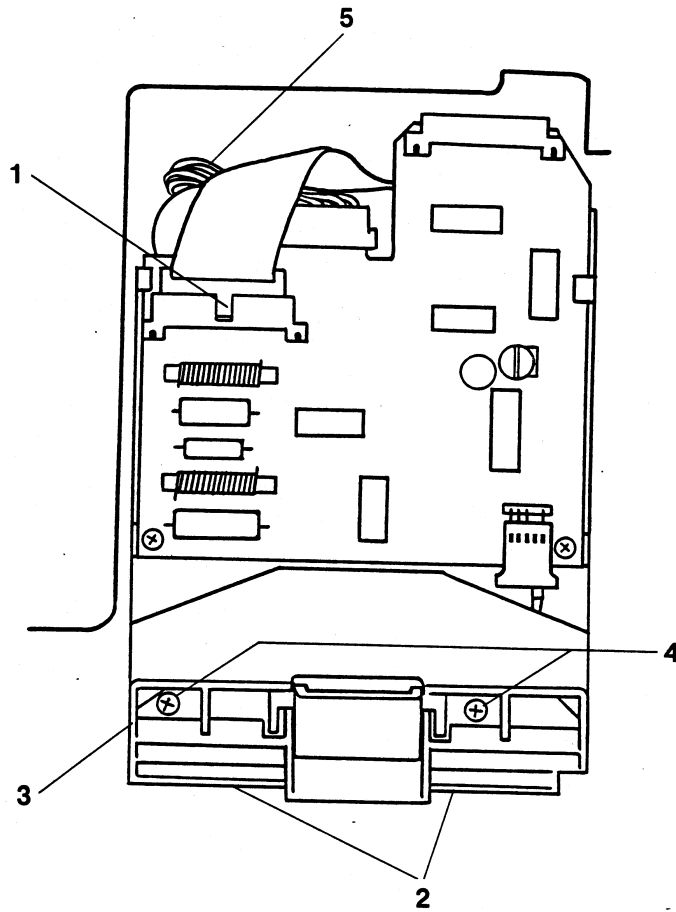

FIGURE 7

E. REMOVING THE DISK ASSEMBLY

1. Remove the cover.
2. Remove the Analog card.
3. Draw a pencil line on the Apple III chassis along the front (See Figure 7, Item 2) and left side (Figure 7, Item 3) of the disk assembly bezel. This will serve as a location reference when the disk assembly is re-inserted.
4. Loosen completely (but don't remove yet) the two Phillips head screws that mount the disk assembly to the Apple /// chassis. They can be seen by looking down through the front diskette guide and door assembly. (See Figure 7, Item 4).
5. Loosen but don't remove the screw in the double retaining clip that secures the back of the disk assembly. (See Figure 7, Item 5).
6. Remove the assembly by sliding it forward until it clears the retaining clip. Lift it from the chassis.
7. Recover the two front screws from the disk assembly.

F. REPLACING THE DISK ASSEMBLY

1. Slip the disk assembly under the double retaining clip so that the front is in line with the pencil line you drew earlier.
2. Replace the two front screws.
3. Tighten the retaining clip screw in the back.
4. Replace the Analog card.
5. Replace the cover.

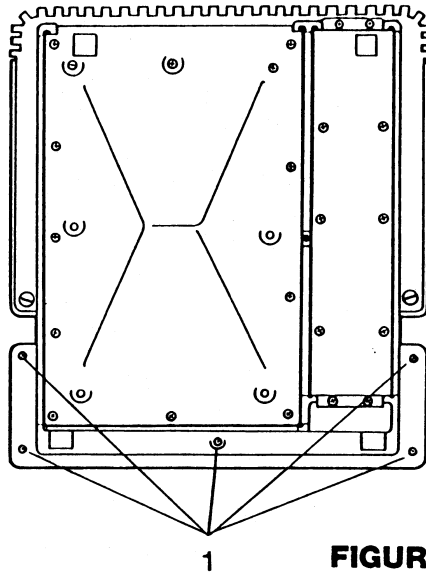

FIGURE 8

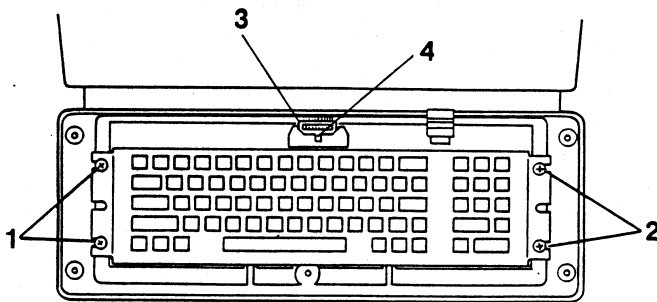

FIGURE 9

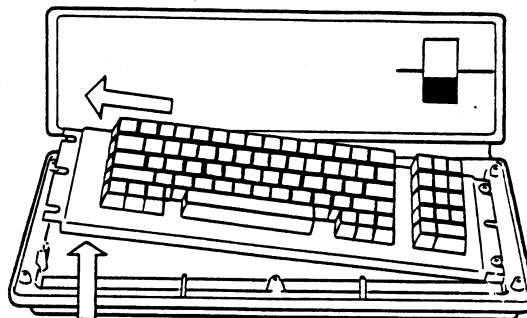

FIGURE 10

G. REMOVING THE KEYBOARD

1. Check to see that the power is off on the Apple /// and that the AC power cord is disconnected.
2. Turn the Apple completely over.
3. Remove the five keyboard cover mounting screws. (See Figure 8, Item 1).
4. Remove the keyboard cover.
5. Turn the Apple rightside up again.
6. Remove the two retaining screws on the left end of the keyboard. (See Figure 9, Item 1).
7. Loosen but don't remove the two retaining screws on the right. (See Figure 9, Item 2).
8. Remove the keyboard by lifting the left end and sliding the right end from under the loosened screws. (See Figure 10).
9. Disconnect the keyboard cable (See Figure 9, Item 3) by using a screwdriver to push on the tab or the sides of the cable connector (See Figure 9, Item 4).

CAUTION: Do not pull on the cable!

H. REPLACING THE KEYBOARD

1. Replace the keyboard cable. Make sure it wraps tightly around the printed circuit board and does not stick out.
2. Replace the keyboard.
3. Replace the two retaining screws on the left end of the keyboard.
4. Tighten down the two screws on the right side of the keyboard.
5. Replace the keyboard cover.
6. Tip the Apple /// up, keeping one hand on the loose keyboard cover.
7. Carefully replace the five keyboard cover mounting screws. Don't overtighten them because they are just threaded into the plastic of the cover and will strip very easily.

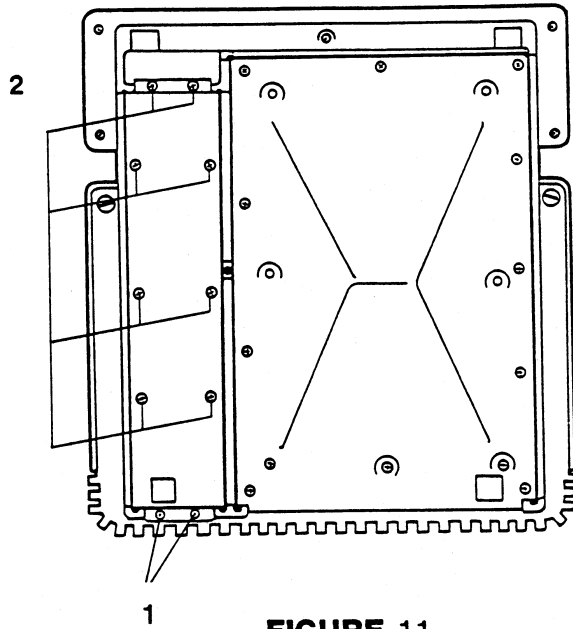

FIGURE 11

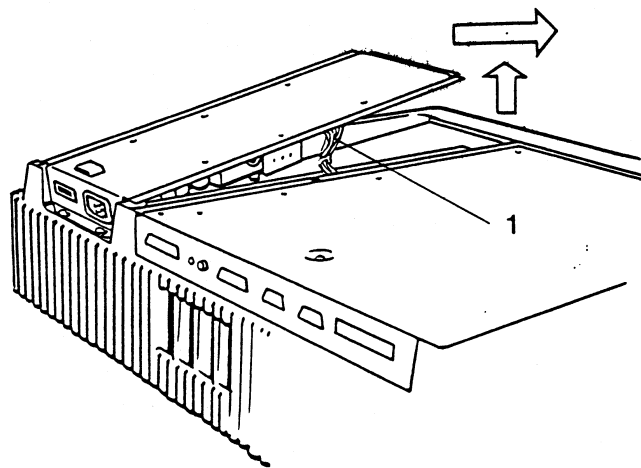

FIGURE 12

I. REMOVING THE POWER SUPPLY

1. Make sure that the power is off on the Apple /// and that the AC power and all other external cables are disconnected.
2. Turn the Apple upside down with the back facing you, putting it on a soft pad.
3. Loosen but don't remove the two Phillips head screws located on the rear edge of the power supply bottom cover, near the on/off switch and power supply receptacle. (See Figure 11, Item 1).
4. Completely loosen the eight screws that secure the power supply to the chassis. Do not try to take them out (See Figure 11, Item 2).
5. Lift up the edge of the power supply and slide it until it clears the two rear mounting screws. Lift the power supply out. (See Figure 12).
6. Turn the power supply over.
7. Disconnect the power supply connector by squeezing in on the tabs and gently (with a rocking motion) pull the connector out. (See Figure 12, Item 1).
8. If there is a wire tie holding the cable, clip it.

J. REPLACING THE POWER SUPPLY

1. Place a new wire tie on the cable.
2. Plug in the cable connector.
3. Replace the power supply. Slide the cover under the two rear screws and lower the power supply into place.
4. Tighten down all the screws. **BE CAREFUL! DON'T FORCE THE SCREWS!** If excessive force is applied, the screws will strip out the chassis. Make sure the screws are not crossthreaded. If one doesn't go in easily, back it out and try again.

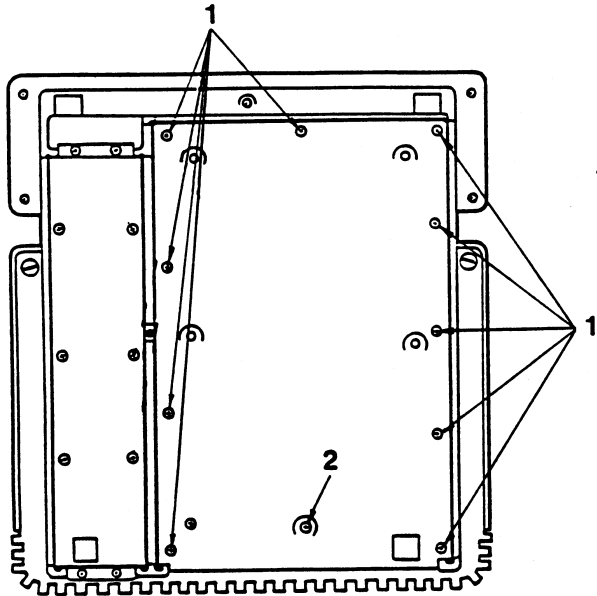

FIGURE 13

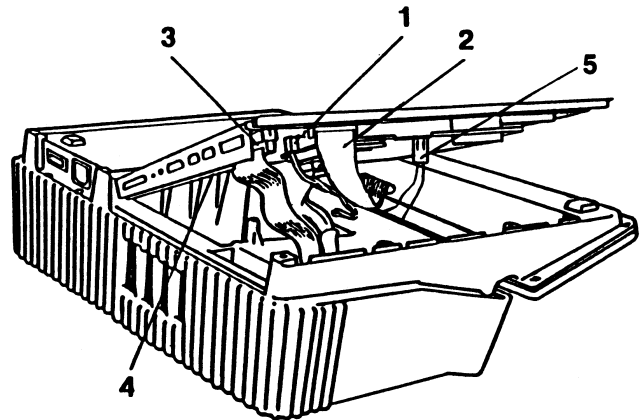

FIGURE 14

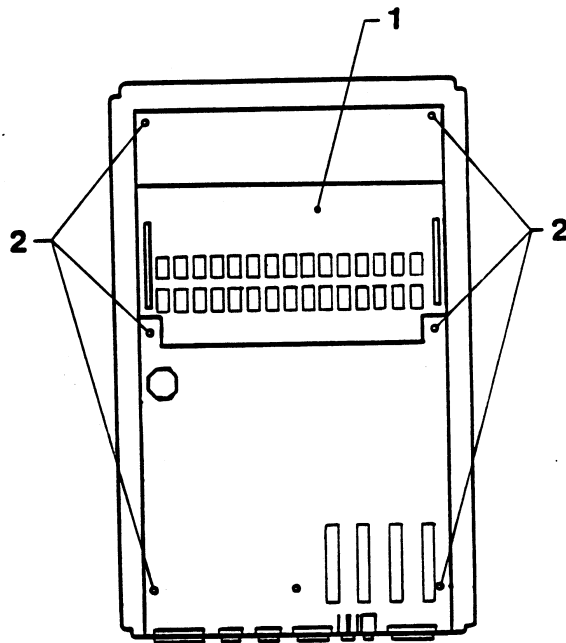

FIGURE 15

K. REMOVING THE MAIN LOGIC ASSEMBLY

1. Make sure that the power on the Apple is off and that all external cables are disconnected.
2. Tip the Apple /// on its side.
3. Loosen the two locking screws that hold the cover on.
4. Remove the cover.
5. Remove any peripheral cards installed in slots 1 - 4.
6. Put the Apple cover back on to protect the disk bezel.
7. Place the Apple upside down and put it on a pad with the rear facing you.
8. Remove the ten Phillips screws around the edge of the logic access panel. (See Figure 13, Item 1.)
9. Remove the additional recessed screw that is about one and a half inches in from the rear edge of the panel. (See Figure 13, Item 2).
10. Lift up the logic board carefully from the right side. Allow the panel to remain resting on its edge nearest the power supply. (See Figure 14.)
11. While holding the logic board on the underside, disconnect the clock/calendar cable, if present (Figure 14, Item 5) the speaker cable (Figure 14, Item 1), the keyboard cable (Figure 14, Item 2), and the disk drive cable (Figure 14, Item 3). Note which plug goes where.

NOTE: The clock/calendar is optional on the Apple /// but standard on the Apple /// Plus.

12. Lift the assembly so that you can unplug the power supply plug. (Figure 14, Item 4).
13. Lift out the logic assembly.
14. Place the logic assembly flat on the work surface. Using both hands, lift off the memory board (See Figure 15, Item 1) from the main logic board (Motherboard).

NOTE: Lift the memory board straight up so that the male connector pins mounted on the main logic board will not be bent or broken.

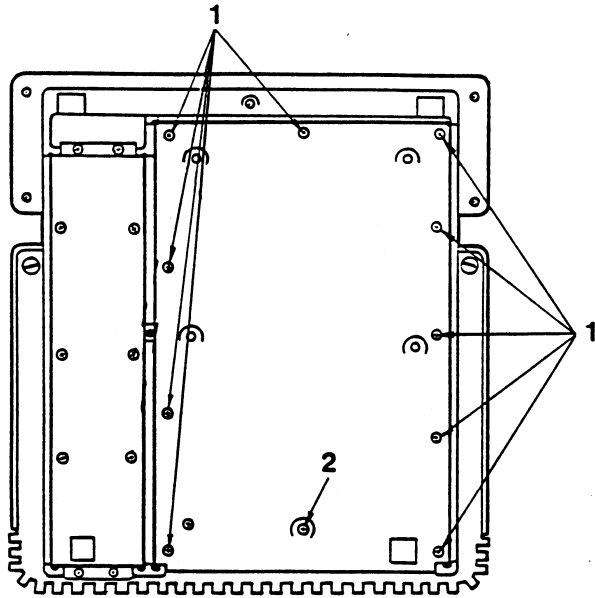

FIGURE 13

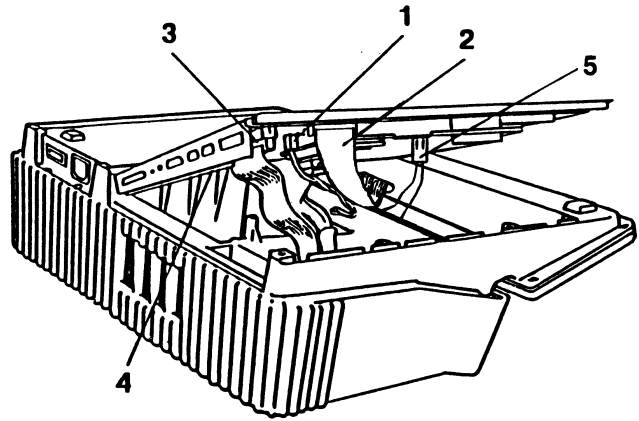

FIGURE 14

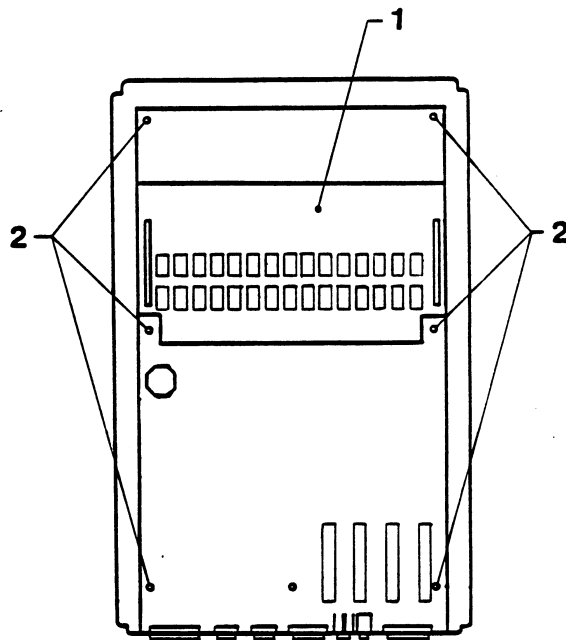

FIGURE 15

15. Remove the six retaining screws on the main logic board. (See Figure 15, Item 2).
16. Ease the main logic board forward so that the peripheral connectors slip out of their cutouts.
17. Remove the main logic board.

NOTE: Be sure to remove the clock chip (location B3) and the battery adapter and clamp prior to returning the main logic board for exchange. Refer to "Installing the Apple /// Clock Kit" in **Section 4, Modifications**, for the location of these components.

L. REPLACING THE MAIN LOGIC ASSEMBLY

NOTE: See **Section O, Apple /// Service Notes** for module exchange information.

1. Make sure that the insulating shield (present only on early models of the Apple ///) is in place to keep the board from shorting on the access panel.
2. Replace the main logic board by slipping the peripheral connectors into their cutouts in the rear access panel, and then replacing the retaining screws with the screwdriver (Figure 15, Item 2).
3. Replace the memory board (Figure 15, Item 1), making sure memory board is properly oriented. (The RAM chips on the memory board point in the opposite direction to the chips on the main logic board. The notches on the memory board IC's should be facing the output connectors.)

Align the end pin in the end hole of the memory board and then tip the board flat. When all pins are properly started, press the board gently but firmly into place.

4. Rest the access panel on the power supply side and reach under and plug in the power supply (Figure 14, Item 4).
5. Plug in the speaker cable (Figure 14, Item 1).
6. Plug in the keyboard cable (Figure 14, Item 2).
7. Plug in the disk cable (Figure 14, Item 3).
8. Plug in clock/calendar cable, if present (Figure 14, Item 5).
9. Put the entire logic assembly panel in place and tighten down the 11 Phillips screws on the logic assembly access panel. (See Figure 13, Items 1 and 2).

10. Turn the Apple /// rightside up.
11. Remove the cover.
12. Replace the peripheral cards.
13. Replace the cover.

Apple /// Technical Procedures

Section 2

Diagnostics

Contents:

Diagnostics Setup..... 2.3
Diagnostics Menu.....2.3
Making Test Diskettes.....2.4
Test All.....2.5
Video Tests.....2.5
Sound Tests.....2.7
Disk Test.....2.7
Keyboard Tests.....2.8
ROM Test.....2.9
RAM - 5V and RAM - 12V Tests.....2.9

The Apple /// Dealer Diagnostics diskette (P/N 077-0013A) is to be used with the Troubleshooting Flowchart (below, section 3). This section describes how to run the tests on the diskette. Normally (see section D) you will use the TEST ALL option to run all the tests in sequence. If you wish to run or repeat an individual test, simply use the up- and down-arrow keys to select that test from the main menu and press RETURN to accept it.

1

FIGURE 1

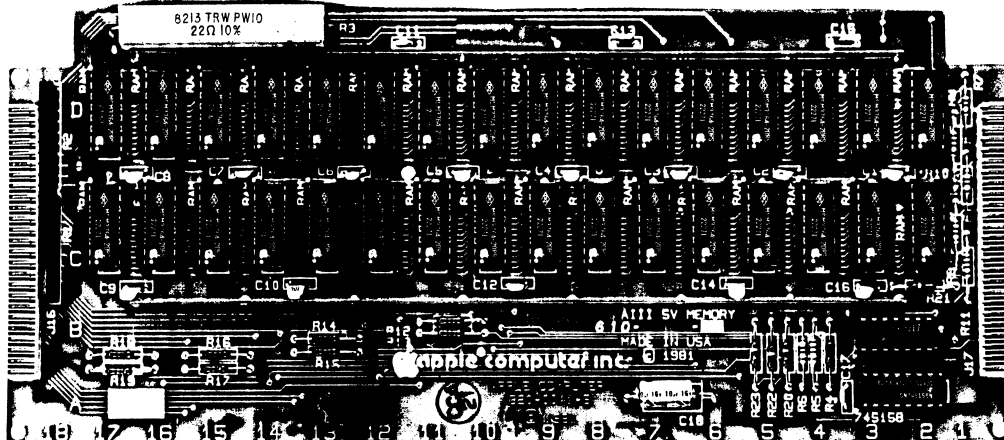

5V MEMORY BOARD

1

FIGURE 2

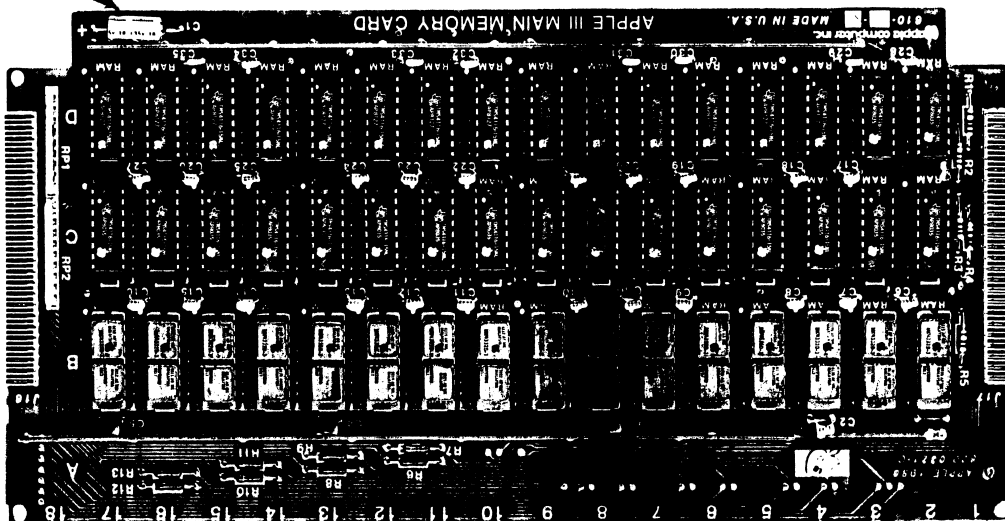

12V MEMORY BOARD

A. DIAGNOSTICS SETUP

NOTE: Before using the Diagnostic Diskette, make a backup by using the Device Handling Commands on the System Utilities diskette.

1. Determine whether the system under test has a 5-volt or a 12-volt memory board. (Early models of the Apple /// use a 12-volt memory board; later models use a 5-volt board. For the RAM tests (below, p.2.9), you need to know which style board is in the system under test.)
 - a) Power down the Apple /// and remove the top cover.
 - b) Look straight down through the main opening toward the front of the chassis. You will see the edge of the memory board projecting from under the keyboard, and on the left corner of the board you will see either a large grey ceramic resistor (5V board: Figure 1, #1), or a small blue tubular capacitor (12V board: Figure 2, #1).
 - c) Write down which type board is in the Apple ///.
2. Replace the cover, and check to see that your Apple /// and associated peripherals are all properly connected.
3. Insert the diagnostics diskette into the internal disk drive and boot the system.

B. DIAGNOSTIC MENU

After you have successfully booted the diagnostic program, you will see the menu below displayed on the monitor screen.

```

                MAIN MENU
TEST ALL

VIDEO                (NOT TESTED)
SOUND                (NOT TESTED)
RAM TEST - 5V        (NOT TESTED)
DISK                 (NOT TESTED)
KEYBOARD            (NOT TESTED)
ROM                 (NOT TESTED)

RAM TEST - 12V        (NOT TESTED)
MAKE TEST DISKS

PRESS:  UP/DOWN ARROWS TO SELECT TEST
        RETURN TO RUN TEST
PRESS:  ESC(APE) TO QUIT
    
```

NOTE: Because the Apple /// runs several internal diagnostics before booting, having come this far is a vote of confidence for correct system operation.

You will notice that TEST ALL is highlighted in inverse video. The inverse video indicates which test will be run when RETURN is pressed.

The UP/DOWN Arrows will move the inverse cursor line through the list of menu options one-by-one. Pressing RETURN will accept and run the highlighted menu option.

Pressing the ESCAPE key will exit the diagnostics program altogether.

C. MAKE TEST DISKS

In order to run the DISK TEST (below, p. 2.7), you must first make a test diskette for each disk drive in the system.

1. Press the Down Arrow several times until "MAKE TEST DISKS" is highlighted.
2. Accept this option by pressing the RETURN key.
3. Remove the diagnostic diskette from the internal drive.
4. When asked for the drive number for which you will create your test diskette, type a number which corresponds to the drive (1 = INTERNAL; 2, 3, and 4 = EXTERNAL) and press RETURN. If you have more than one drive, you must make a test diskette for each drive.
5. Insert a blank diskette into the internal drive. Close the door and press RETURN.
6. When the test diskette is complete, you will be asked if you want to make another test diskette. To create a test diskette for another drive type "Y", press RETURN, and follow the directions on the screen.
7. When finished, reinsert the Dealer Diagnostic Diskette into the internal drive and reboot the system.

Now you are ready to run the diagnostics on your Apple ///.

D. TEST ALL

Normally you should run all the tests when checking out a system. Accepting the TEST ALL option will cause all the tests on the menu (except the RAM - 12V test) to be run one-by-one as if they were selected one at a time.

1. Skip through the tests with the arrow keys until TEST ALL is highlighted.
2. Accept this option by pressing RETURN, and follow through the tests, referring to the notes below where necessary.
3. TEST ALL runs the RAM - 5V test automatically, but **not** the RAM - 12V test. If you are testing a system that has a 12V memory board, the RAM - 5V memory test will check the RAM. If no errors are encountered, the RAM on the 12V board is good. Should the RAM - 5V test fail, run the RAM - 12V test to get the proper location of the failed components. (See RAM - 5V and RAM - 12V TESTS, p. 2.9.)
4. If any errors are encountered, refer to the Apple /// Troubleshooting job aid to determine follow-up action.

E. VIDEO TESTS

The VIDEO diagnostic tests all the various screen and color modes available on the Apple ///. You will be presented with 13 different video displays and be asked to make a subjective evaluation of each one. After each display is presented, press:

SPACE BAR.....IF THE DISPLAY PASSES
RETURN KEY.....IF THE DISPLAY FAILS
ESCAPE KEY.....TO LEAVE THE VIDEO TESTS
LEFT ARROW KEY.....TO RETRY THE TEST

NOTE: With a B&W monitor, different colors will be displayed as different shades of grey. Some B&W monitors are not capable of displaying all the different shades with a single setting of the monitor controls; in particular, parts of the AHIREs screens will be hard to see. You can adjust the brightness control on the back of the monitor to make the picture visible; you should not expect it to be perfectly clear on a B&W monitor.

You will find the chart describing your video display on the next page. The list is in the same order as the test.

WHAT YOU SEE

TEST DISPLAY	B&W MONITOR	COLOR MONITOR
HIRES MODE 1	B&W Pattern only	No Color
HIRES MODE 2	B&W Pattern only	No Color
280 x 192 COLOR HIRES MODE	Negative image	Red and Black
280 x 192 COLOR HIRES MODE 2	B&W Pattern	Green & White/ or Yellow
SUPER HIRES TEST 1	B&W Pattern only	No Color
SUPER HIRES TEST 2	B&W Pattern only	No Color
AHIRES TEST 1	Pattern divided into 4 different shades of grey.	From top to bottom, the pattern is colored: blue, green, & gold or orange.
AHIRES TEST 2	Pattern divided into 4 different shades of grey.	From top to bottom, the pattern is colored: blue, green, & gold or orange.
COLOR BAR & GREY SCALE TEST.	16 shades of grey from white on left to black on right— may be difficult to resolve.	16 color shades, from left to right: white, aqua, yellow, green, pink, grey, orange, brown, light blue, medium blue, grey, dark green, light purple, dark blue, magenta and black.
APPLE II TEXT MODE 1	Sentence and Alphabet are displayed.	Same as B&W
APPLE II TEXT MODE 2	large #2 is displayed.	same as B&W
APPLE /// 40 COLUMN TEXT MODE	16 blocks of different shades of grey, with color names printed in each box.	16 different colored blocks with the color names printed in each box.

TEST DISPLAY	B&W MONITOR	COLOR MONITOR
APPLE ///	smaller characters	same as B&W
80 COLUMN	across 80 columns	
TEXT MODE		

F. SOUND TESTS

The SOUND diagnostic has 3 parts: a soft bell, a hard bell, and a sound that gradually grows in amplitude. After each sound, press:

SPACEBAR.....IF YOU HEAR THE SOUND
 or RETURN KEY.....IF YOU DO NOT HEAR THE SOUND

G. DISK TEST

The DISK TEST tests the seek and the read-write functions of the disk drives. IT IS VERY SENSITIVE AND MAY FAIL A DRIVE THAT IS ACCEPTABLE AND USABLE. If a drive passes this test, you can be sure it is good. If it fails, see note at end of this section.

NOTE: Before running the DISK TEST you must have made test diskettes (see section C above).

1. Remove the dealer diagnostic diskette from the internal drive.
2. Insert the test disk that you created earlier. Close the drive door and press RETURN.
3. You will now be asked for the number of external drives. Type the number of external drives in the test system (i.e., do not count the internal drive) and then press RETURN.
4. The test will now run automatically, ending with a test summary, telling you which drives have passed or failed.
5. Remove the test diskette from the internal drive.
6. Reinsert the diagnostic diskette and press RETURN.

NOTE: IF A DRIVE FAILS THE DISK TEST, 1) TRY THE TEST AGAIN WITH A DIFFERENT TEST DISKETTE (a worn test disk can cause failure); 2) TEST THE D-SPEED USING THE APPLE][CALIBRATION OR DISK ALIGNMENT AID DISKETTE IN EMULATION MODE, AND ADJUST IF NECESSARY [SOS 1.3 has a narrow tolerance (+ or - 10), so get as close to 0 as possible]; THEN TRY THE DISK TEST AGAIN. IF THE DRIVE STILL FAILS, SEE THE APPLE ///
 TROUBLESHOOTING CHART.

H. KEYBOARD TESTS

The keyboard test is divided into 4 parts:

1. Alphanumeric Keys
2. Special Function Keys
3. Numeric Keypad Keys
4. Keyboard Interrupt

NOTE: The steps below must be followed exactly or the test will fail.

1. Alphanumeric Keys:

Every alphanumeric keystroke possible will be displayed on the screen. As you press the keys, their characters should disappear. Do not use the SHIFT key except where directed to, and press the SPACE bar last.

- a) Press the left SHIFT key and while holding it down press the 2 key.
- b) Press the right SHIFT key and while holding it down press the = key.
- c) Press the CONTROL key and while holding it down press the A key.
- d) Press all the remaining keys on the main keyboard except the SPACE bar. Each time a key is pressed, its character should disappear from the screen.

2. Numeric Keypad Keys:

This test proceeds in the same manner as the Alphanumeric Key test, but for the keys on the numeric keypad.

After you have removed all of the keys displayed on the monitor, you will automatically go to the Special Function Keys test. Notice that you can abort this test at any time by pressing ESCAPE.

3. Special Function Keys:

- a) After the special function keys appear press the ALPHA LOCK key twice. This will test the ALPHA LOCK key. **Be sure the ALPHA LOCK key is left in the up or unlock position.**
- b) The diagnostic will then ask you to press the SPACE BAR and to hold it down. This is to test the slow repeat function. Don't release the SPACE BAR: to complete the next step you must still be holding the SPACE BAR down.

c) Next, you will be asked to press the OPEN APPLE key and SOLID APPLE key down simultaneously. This tests both the OPEN APPLE key and the fast repeat function.

d) Now release all the keys; then press first the SOLID APPLE key and then the SPACE BAR. This is to test the repeat inhibit function.

4. Keyboard Interrupt Test:

When the keyboard interrupt test comes up on the screen simply press any key to continue. The diagnostic will inform you of the keyboard status and then return to the main menu.

J. ROM TEST

The system takes over and you will see one of two messages:

ROM PASSES . . . or ROM FAILS . . .

NOTE: If you selected the TEST ALL option from the main menu, you will be returned to the menu after the ROM test. The test results will be displayed to the right of each test option.

K. RAM - 5V and RAM - 12V TESTS

If you use the TEST ALL option, the system will automatically run the 5V test, and if it reports no errors, you can be confident that all RAM are good, no matter which style of board is installed in the Apple ///. If it reports failures, however, you must run the RAM - 12V test in order to obtain the correct locations of failed RAM.

The instructions for both tests are the same (except for reading the failure messages). Read through the steps below, and then run the test.

1. Get the memory size from the bottom of the Apple /// where the serial number is located.
2. Select either the RAM - 5V or the RAM - 12V test, depending on the style of memory board in your Apple (see Section A above, p. 2.3), and press RETURN to begin the test.

CONTINUED ON NEXT PAGE

3. The test will now attempt to determine the size of memory in the system. There are three possible outcomes:
 - a) A screen will appear with the correct memory size. Press the SPACE bar and the RAM test will start.
 - b) A screen will appear with the wrong memory size.
 - (1) Press the RETURN key, and
 - (2) A screen will appear and ask you for the correct memory size.
 - (3) Type the letter that corresponds to the correct memory size.
 - (4) The first screen will reappear with the newly selected memory size. If this is correct, press the SPACE bar and the test will start. If the memory size is not correct, press the RETURN key and the second screen will reappear so that you may reselect the correct memory size.
 - c) The test will not be able to determine the size of memory by itself, so a screen will appear and ask you for the correct memory size.
 - (1) Select the letter that corresponds to the correct memory size.
 - (2) A screen will appear with the selected memory size. If this is correct, press the SPACE bar and the test will start. If the memory size is not correct, press the RETURN key and the second screen will reappear so that you may reselect the correct memory size.

NOTE: Selection of the wrong size memory may lead to indication of RAM MAP FAILURE. Reboot the disk and try to run the test again.

4. The test will then check the RAM and report any failures. The 12V test gives RAM locations according to a grid of letters and numbers printed along the side and top of the 12V board (rows B, C, D; columns 2 through 17: see Figure 3).

The 5V test gives RAM numbers (U1 through U32). On early versions of the 5V board, these U-numbers were printed next to the RAM locations on the board; on later 5V boards, the U-numbers are no longer printed: to locate U-numbers on those boards, use Figure 4.

NOTE: If the correct memory is selected and the message RAM MAP FAILURE appears, it may indicate that the memory board or the main logic assembly needs to be replaced. (See Apple /// Troubleshooting Flowchart).

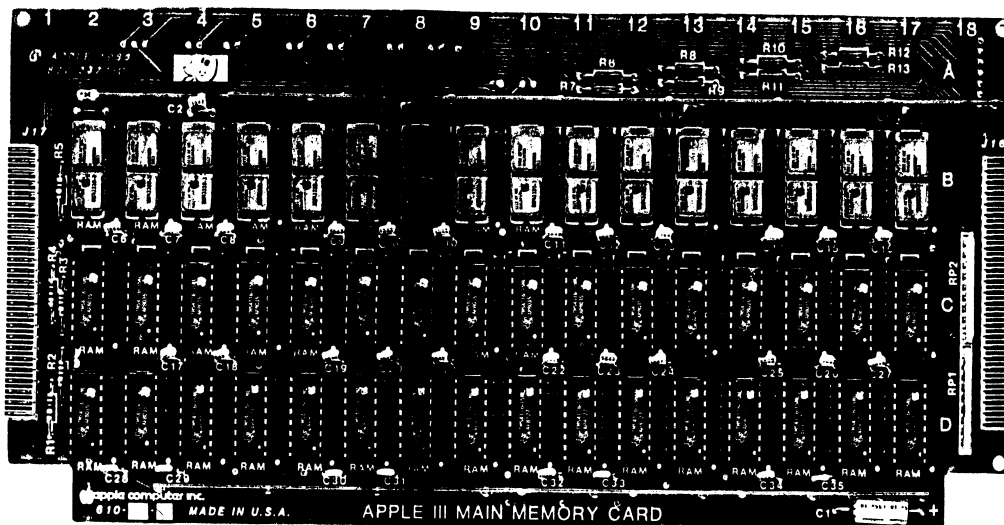

FIGURE 3 — 12V BOARD

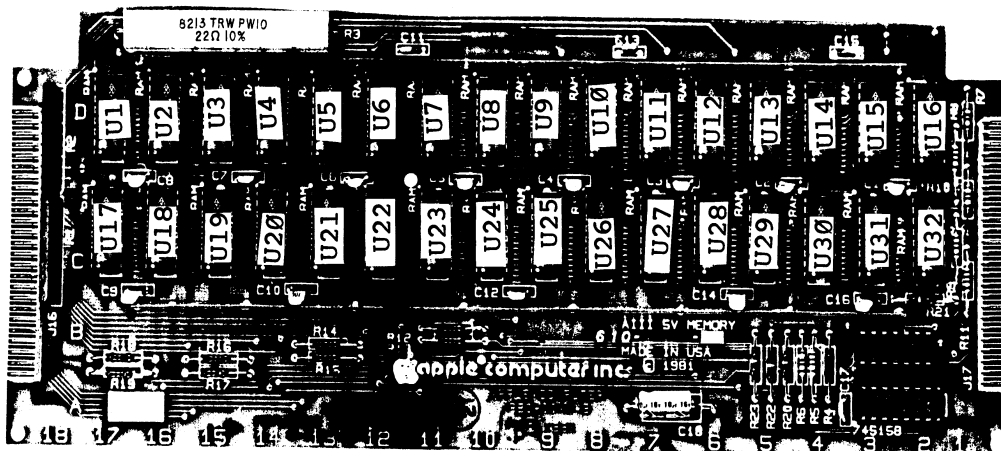

FIGURE 4 — 5V BOARD

Apple /// Technical Procedures

Section 3

Troubleshooting

Contents:

Using the Diagnostic Flowchart.....3.3
Steps Referred to in the Lettered Boxes of the Flowchart..3.4
Profile Problems with the Apple ///.....3.8

A. USING THE DIAGNOSTIC FLOWCHART

P 3.2 blank

1. The flowchart is made up of numbered and lettered boxes. The numbered boxes contain directions for proceeding through the flowchart based on the symptoms that show up on the Apple ///.
2. The lettered boxes contain a list of numbers. Each number refers to one of the 11 steps.
3. Always begin troubleshooting at Box 1 of the flowchart, power on with the SOS System Demonstration diskette. When the Apple ///'s symptoms lead you through the flowchart to a lettered box containing a list of troubleshooting steps, follow the instructions below:
 - a. Turn the power off.
 - b. Carry out the designated troubleshooting step. (Start at the top of the list of numbered steps.)
4. When a troubleshooting step leads you to open the Apple ///, you should:
 - a. Check to make sure all connecting cables are properly hooked up.
 - b. Check all boards to make sure all IC chips are properly seated.
 - c. Power on to see if the problem is eliminated.
 - (1) If the problem IS NOT eliminated:
 - (a) Turn the power off.
 - (b) Replace whatever spare module you just put into the Apple /// with original.
 - (c) Carry out the next troubleshooting step listed in the lettered box.
 - (d) Go back to Step 4c above.
 - (2) If the problem IS eliminated:
 - (a) Leave the swapped module in place and continue through the Diagnostic Flowchart.
 - (b) Take the "bad" module and prepare it for shipment to your Level II Service Center.

5. The Diagnostic Flowchart is designed to test only the basic Apple /// system. Disconnect any peripheral devices and cards and troubleshoot them separately according to the procedures explained in the appropriate Level 1 Service Training module.
6. Each swap step involves exchanging a known good part from your spares kit with the questionable part from the Apple ///.
 - a. When swapping, first just connect the cable(s) to the new module so you can see if the swap fixes things or not.
 - b. Don't fully install the new module and screw everything down--if the new module doesn't solve the problem you'll just have to take it out again.

B. STEPS REFERRED TO IN THE LETTERED BOXES OF THE FLOWCHART

1. Swap the appropriate connecting cable.*
V = Video cable (if available)
PS = Power Supply cable
DD = Disk Drive cable
KB = Keyboard cable

NOTE: The keyboard and disk drive cables are identical to each other. Your Spares Kit may only list the DD cable, but you can use it whenever you need to swap the KB cable.

2. Swap the power supply.
 - a. Check the power supply fuse first; swap it if it's burned out.
3. Swap the drive.
 - a. If the drive proves to be the problem, take the problem drive and further isolate the defective module down to the analog card or mechanical assembly:
 - (1) Swap the analog card.
 - (a) Take the analog card of the "bad drive", put it in the good drive, and power on again. If the drive does not work you know the problem with the "bad drive" is with the analog card. If the drive does work you know the "bad drive" is with the mechanical assembly.

- (b) If the mechanical assembly proves to be the problem it may just be an adjustment problem. You can run the disk tests for the Apple II in emulation mode on the /// and make any necessary adjustments to see if they eliminate the problem.
4. Swap the main logic board.
 5. Swap the keyboard.
 6. Swap the RAM memory board. (You may have to reload the new board with the RAM from the original board.)
 7. Try booting again.
 8. Try booting a different SOS diskette.
 9. Swap the video monitor.
 10. Swap the speaker.
 11. Swap the designated RAM IC chips. (Refer to the Apple /// Diagnostics - Section 2, RAM - 5v TEST and RAM - 12v TEST.)
 12. Look through the back slots of the of the Apple /// to see if the red light (LED) is on. If it is not on:
 - a. Check the power supply fuse first; swap it if it's burned out. (See Apple /// Takeapart - Section 1 "REMOVING THE POWER SUPPLY". Once you have removed the power supply, the fuse will be easy to find.)
 - b. Swap the power supply.
 13. Press CONTROL/RESET (Warmboot); if Warmboot is successful, replace the Power Light.

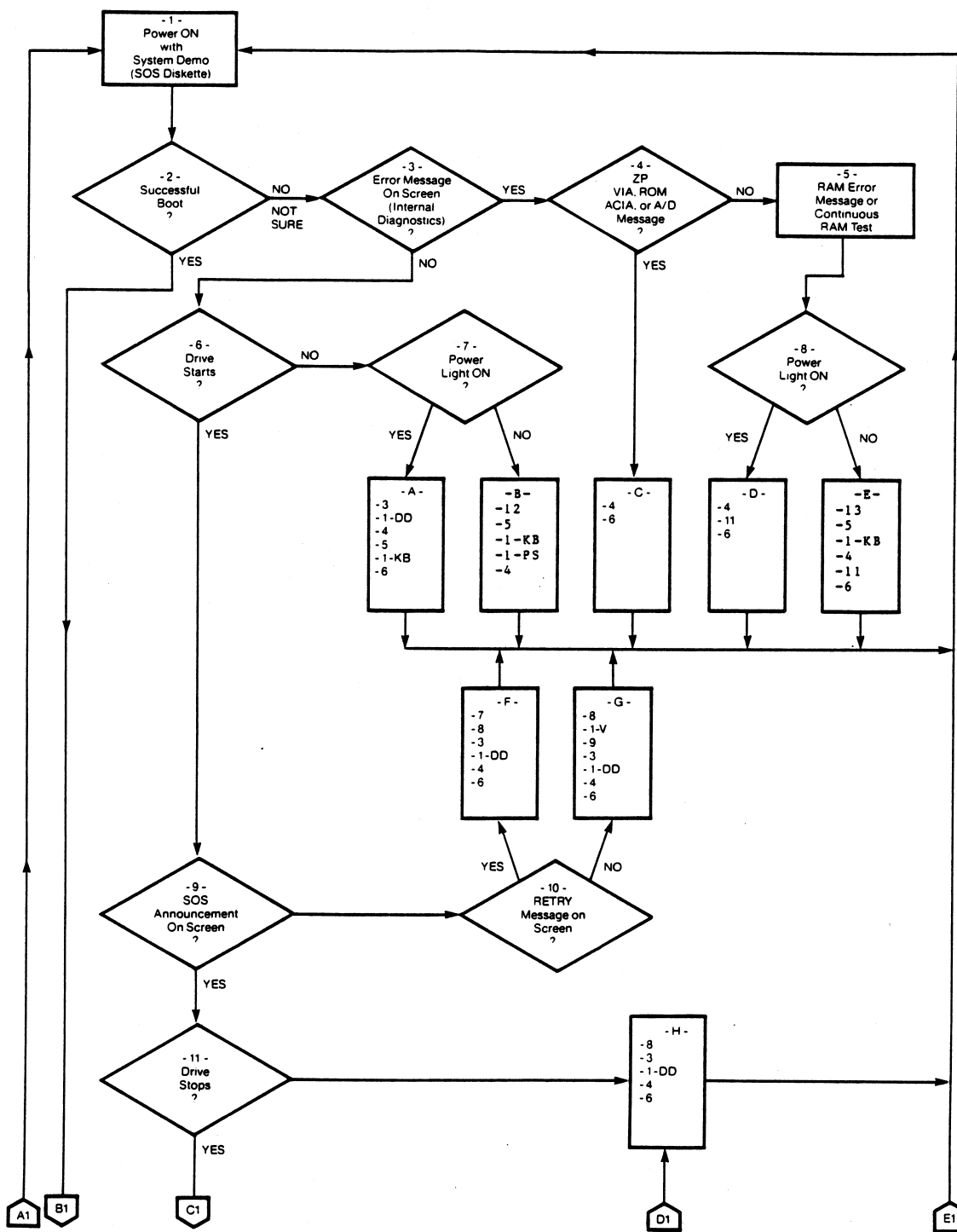

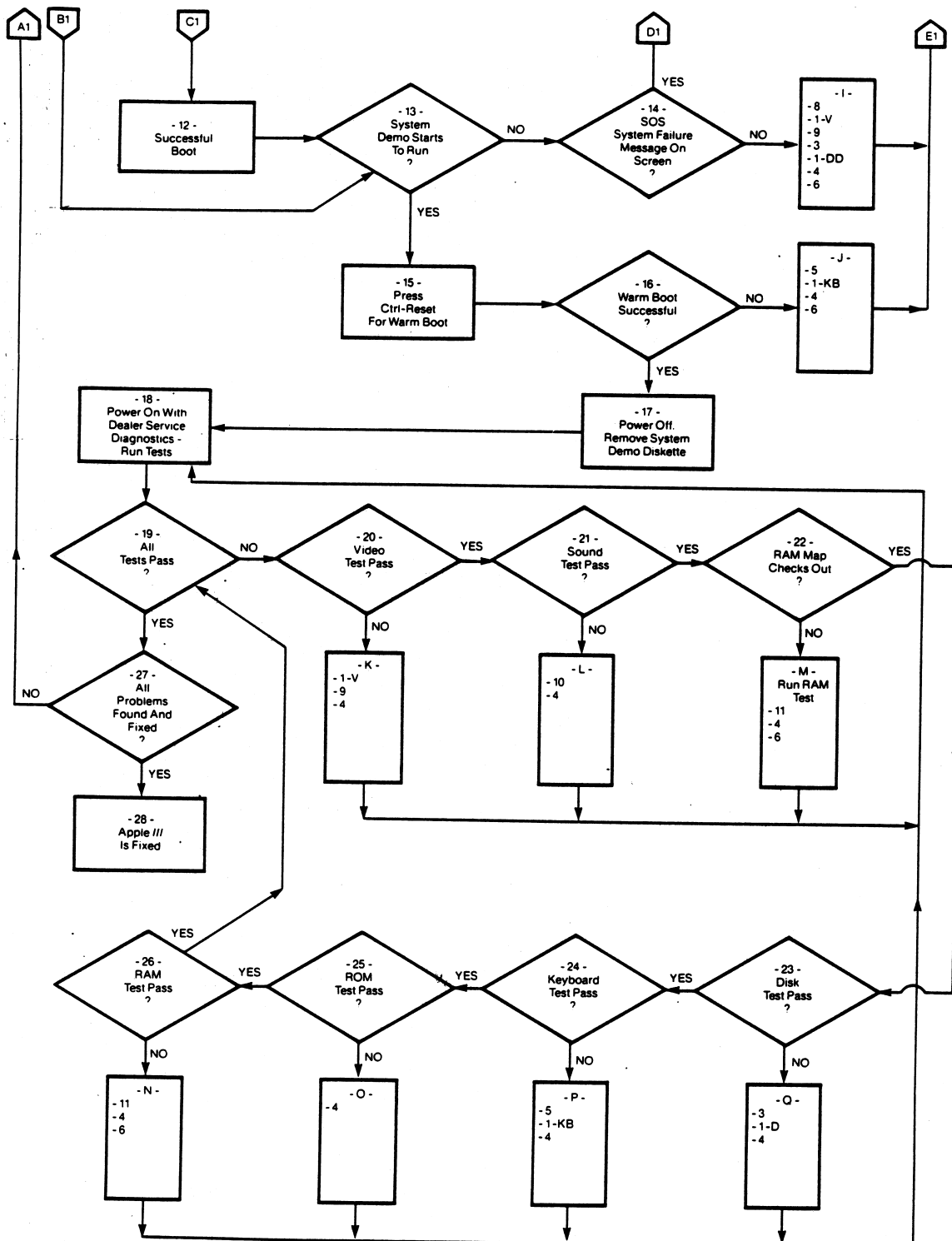

ProFile Problems with the Apple ///

Potential problems may arise when the RFI-shielded cables are used with earlier versions of the Apple /// ProFile Interface Card. The problems range from random data handling errors to unreadable files saved on the ProFile.

The problem is caused by the resistor array values on the Apple /// ProFile Interface Card (at location DM 1 and DM 2). The resistor arrays were changed from 330 Ohms to 100 Ohms. Interface cards with the 330 Ohm resistor arrays (manufactured prior to October 1983) are not compatible with the new ProFile Shielded Cable. An impedance mismatch occurs when the older interface cards are connected to the shielded cable, resulting in various problems.

The following solutions will correct the problem:

1. Use the flat ribbon cables; they will operate on either the 330 Ohm or the 100 Ohm revisions of the ProFile Interface Card.
2. If the RFI-shielded cable is to be used, verify that the Apple /// ProFile Interface Card has 100 Ohm resistor arrays at locations DM 1 and DM 2.

🍏 Apple Technical Procedures

Apple III/III Plus

Section 4 – Modifications

☐ CONTENTS

- 4.2 Installing the Apple III Clock Kit
- 4.4 Setting the Apple III Clock
- 4.6 Adjusting the Apple III Clock Speed
- 4.10 256K RAM Upgrade
- 4.12 Apple III Keyboard Replacement

□ INSTALLING THE APPLE III CLOCK KIT

Materials Required

#1 and #2 Phillips screwdriver
Apple III System Utilities diskette
Apple III Clock Kit
Apple III Clock Calibration diskette

Procedure

1. Remove the Apple III cover and main logic board. Refer to Section 1, Take-Apart, if necessary.
2. Place the main logic board on a flat surface in front of you so that the empty socket at B3 is located to your left. Insert the clock chip into the empty socket with the notch on top of the chip facing toward the front, as shown in Figure 1.
3. Lift the main logic board gently and place the clamp through the two holes on the middle right-hand side of the main logic board as shown in Figure 1. Hold the clamp in place with your finger.
4. Place the battery adapter PCB over the large hole with the long, flat side of the battery adapter PCB toward the right edge of the main logic board as shown in Figure 1. The battery adapter PCB should be seated between the legs of the clamp.
5. Insert the screw through the middle of the battery adapter, and tighten the screw until the battery adapter PCB is snug against the main logic board.
6. Install 3 "AA" alkaline batteries into the battery pack as labeled in Figure 1, and on the battery pack. Now attach the lugs of the red and black wires of the battery cable to the battery case. Observe the proper polarity as shown in Figure 1.
7. Turn the Apple III right-side up. Clip the battery case onto the lip of the casting to the left of the speaker. Run the molex connector end of the battery cable down through the hole below the speaker on the Apple III as shown in Figure 1.

8. Reinstall the main logic board. Be sure to connect the female end of the lug connector to the male end on the battery adapter PCB, now attached to the main logic board.
9. Make all of the necessary connections to the main logic board and reinstall back to the Apple III case. Replace the Apple III cover.

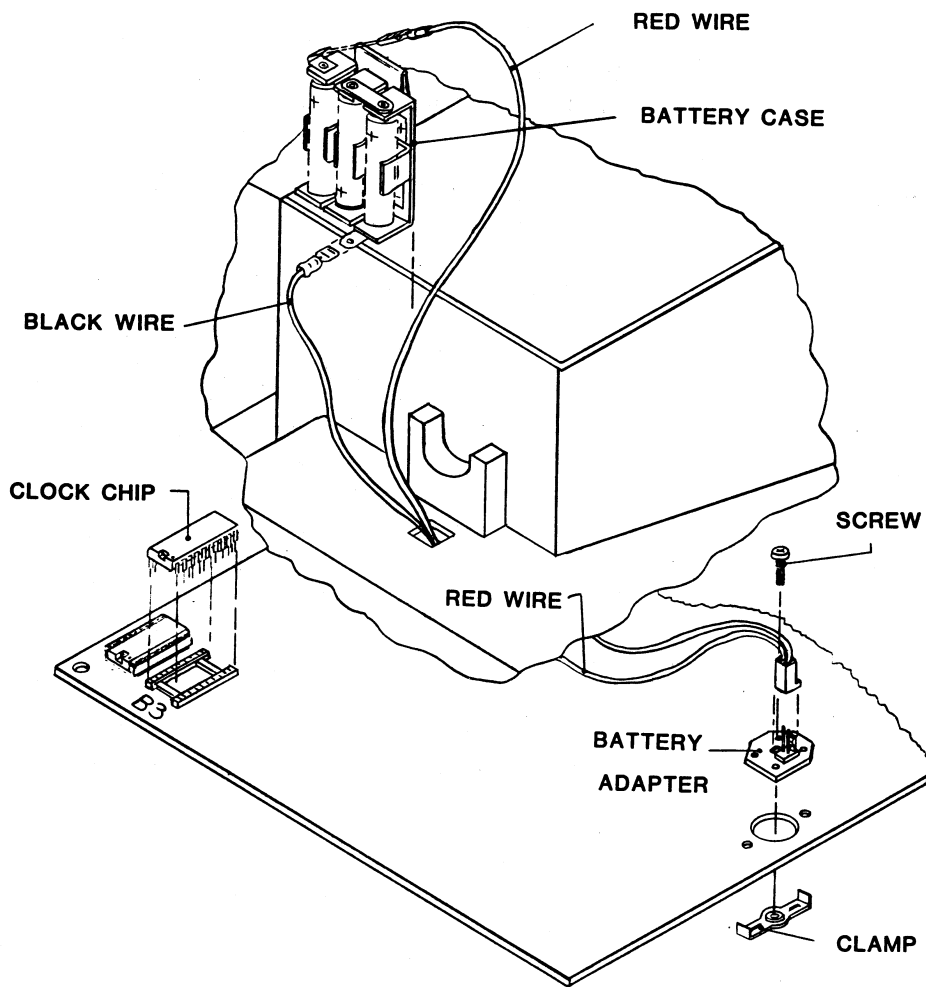

FIGURE 1

□ SETTING THE APPLE III CLOCK

Introduction

In order to calibrate the Apple III clock, the clock time must be set close to the exact second so the number of seconds lost or gained can be determined.

Note: To prevent confusion, any text that is to be entered into the computer is enclosed by curly brackets {}. Type everything, including punctuation, between them; but don't type the curly brackets themselves.

EXAMPLE: If you are supposed to type 1-2-3-4, it will appear in the text as {1234}.

Procedure

1. Boot the Utilities diskette and select {D}, Device handling commands.
2. Select {T} from the Devices Menu; set time and date.
3. The cursor should now be in the lower portion of the screen that says, "Set the date to: []."
4. Type in the date in the format: {day <SPACE> month <SPACE> year}, where the month can either be the numerical representation or a three-letter abbreviation, and then press <RETURN>.

If the date is January 1, 1982, it can be typed as: {1 Jan 82} or {1 1 82}.

5. Find out what the correct time is. You can do that by telephone.
6. The cursor should be in the box that says, "Set the time to: []."
7. Listen to the time on the telephone: you should hear the hour, the minute, the upcoming ten-second mark, and then a beep.

8. Type in the time, including the seconds, which will represent the upcoming beep in the format: {hour:minute:second <SPACE> Xm}.

If the upcoming beep will be 4:10:00 pm, you may enter the time as {4:10:00 pm}, {16:10:00}, or {04:10:00 pm}.

9. When you hear the tone, press <RETURN>.
10. Verify that the beeps occur at the same time that the seconds change on the Utilities time display in the upper-right corner of the monitor.
11. Repeat steps 6 thru 9 until the beeps are approximately concurrent with the seconds displayed on the monitor.

□ ADJUSTING THE APPLE III CLOCK SPEED

Introduction

The Apple III clock is calibrated by comparing the Apple III System clock to the one-second intervals of the clock chip. In order to calibrate the clock within reasonable accuracy, without the use of very expensive calibration equipment, a 24 to 48 hour observation is required.

Note: The keyboard on the Apple III Plus does not have to be removed to adjust the clock speed. The trimmer capacitor can be adjusted by inserting a screwdriver through a small hole in the bottom of the base plate, underneath the keyboard (Figure 2, #1).

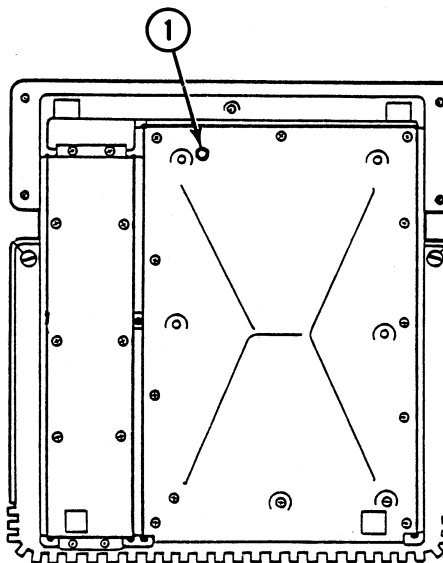

FIGURE 2

Procedure

1. Disconnect all connectors from the back of the Apple III.
2. Turn the Apple III over and remove the 5 screws that fasten the beige keyboard cover to the case.
3. Remove the keyboard cover. Then turn the Apple III rightside up and remove the 4 screws that hold the keyboard in place.

4. Connect the power cord and the video cable and boot the Apple III Clock Calibration Program.
5. Select the 10-second interval by pressing down the <ALPHA LOCK> key.
6. Lift the keyboard up and lay it carefully against the sloped Apple III front cover.
7. Wait until the speaker clicks twice (20 seconds) and note the value of the indicated number. The number should read +560, ± 9 .
8. If the indicated number is not within the range indicated in step #7, adjust the trimmer capacitor located in the center of the keyboard with a small screwdriver. When you adjust the trimmer pot, the number will not change right away; it takes 10 seconds to update. Turn the trimmer capacitor clockwise to increase the value and counterclockwise to decrease the value.

Note: On the Apple III Plus, the trimmer capacitor can be turned through the hole in the keyboard (Figure 2, #1). You do not have to take the keyboard apart.
9. Wait until the speaker clicks at least twice to ensure that the indicated number remains constant.
10. Repeat steps 7 thru 9 until the indicated number is between 551 and 569 (+560, ± 9). Once the number has been set it may vary slightly.
11. Record the indicated number of the Apple III Calibration Program on a piece of paper and attach it to the front of the Apple III.
12. After approximately 24 hours, boot the Utilities diskette and press {D}.
13. Find out the correct time. You can do that by calling the local time on the telephone.
14. Note the difference between the ten-second beeps on the telephone and the seconds on the Apple III clock in the upper right corner of the monitor.

15. Record the time difference to the closest 1/2 second on paper.
16. If the observation period has been longer or shorter than 24 hours, calculate the number of 24-hour periods by dividing the observation period by 24. Let's walk through an example:

Suppose an Apple III clock has been running for 28 hours and has gained 5 seconds. The current value of the Apple III Clock Calibration Program is +780.

Observation period in hours + 24 = Number of 24-hour periods.

$$28 \div 24 = 1.16 \text{ (24-hour periods).}$$

17. Calculate the time difference in seconds per 24-hour period by dividing the time difference recorded in step #14 by the Number of 24-hour periods.

Time Difference + Number of 24-hour periods =
Time Difference in seconds per 24-hour period.

$$5 \div 1.16 = 4.31 \text{ seconds difference per 24-hour period.}$$

18. Calculate the Clock Offset by multiplying the Number of seconds per 24-hour period by 118.

Time Difference in seconds per 24-hour period X
118 = Clock Offset

$$4.31 \times 118 = 508.58$$

19. Calculate the new Apple III Clock Calibration value by adding or subtracting the clock offset. If the clock is gaining time, the offset value is subtracted from the Apple III Clock Calibration Value. If the clock is losing time, the offset value is added to the Apple III Clock Calibration Value.

Since the clock is gaining time, we subtract from the old value:

$$780 \text{ (old value)} - 508.85 \text{ (offset)} = 271.15 \text{ (new value)}$$

20. Adjust the Apple III Clock Calibration Program Value to the new value found in step 19, following the procedure in steps 7 through 9.

Example

An Apple III clock has been running for 34 hours and has lost 2 seconds. The value of the Apple III Clock Calibration Program is +480. What value should the Apple III Clock Calibration Program indicate after adjustment?

1. Number of 24-hour increments: $34/24 = 1.42$
2. Number of seconds per 24-hour period: $2 + 1.42 = 1.41$
3. Clock offset: $1.41 \times 118 = 292.64$
4. New Calibration Program value: $480 + 293 = 773$

□ 256K RAM UPGRADE

Introduction

To upgrade an Apple III from a 128K 12-volt RAM system to a 256K 5-volt RAM system, you will need to remove a resistor, solder a jumper wire, exchange two PROMs, and replace the 128K 12-volt memory board.

Identification

For the 128K 12-volt memory board, the Apple III logic board has PROM 341-0041 at coordinate C13, PROM 341-0044 at coordinate C11, and resistor R58 at coordinate D14.

For the 256K 5-volt memory board, the Apple III logic board has PROM 342-0063 at coordinate C13 and PROM 342-0061 at coordinate C11. Resistor R58 is removed and a jumper is installed at coordinate D14.

Materials Required

Soldering tools
Wire cutters
PROM 342-0063 and 342-0061
256K 5-volt memory board

Procedure

1. Remove the 128K logic board and memory board from the Apple III case. Then remove the 128K memory board from the logic board.
2. Locate the resistor R58 at coordinate D14 on the logic board.
3. Remove the resistor by cutting both leads with a pair of wire cutters. Once the resistor is removed, two small solder pads are visible.
4. Solder a small piece of wire to connect the pads.
5. Verify the connection with a voltmeter, if one is available.
6. Remove the two PROMs; one is at coordinate C13 (P/N 341-0041); the other is at coordinate C11 (P/N 341-0044).

7. Install the two new PROMs, one at coordinate C13 (P/N 342-0063), the other at coordinate C11 (P/N 342-0061).
8. Install the 256K memory board on the logic board.
9. Replace the logic board and the memory board in the Apple III system and run the diagnostic.

□ APPLE III KEYBOARD REPLACEMENT

Introduction

The Apple III keyboard (P/N 661-91022) is no longer available as a replacement module. If you order an Apple III keyboard (P/N 661-91022), you will receive an Apple III Plus keyboard, keyboard cover, and keyboard encoder ROM. To replace a defective Apple III keyboard, exchange the Apple III keyboard, keyboard cover, and ROM with the new Apple III Plus keyboard, keyboard cover, and ROM. The old ROM is P/N 341-0034; the new replacement ROM is P/N 341-0136 or P/N 342-0136.

Materials Required

Grounded workbench and wriststrap
Medium flat-blade screwdriver
Small Phillips screwdriver
Medium Phillips screwdriver
IC extractor
Apple III Plus keyboard encoder ROM
Apple III Plus keyboard
Apple III Plus keyboard cover

Procedure

To replace the Apple III keyboard:

1. Power off the Apple III and disconnect the AC power cord.
2. Remove the monitor and disconnect all other external cables from the back of the Apple III.
3. Remove the cover. Refer to Section 1, Take-Apart, if necessary.
4. Remove any peripheral cards installed in slots 1 through 4. Grasp each card by the upper edges and pull straight up to remove.
5. Replace the cover to protect the disk drive bezel. Refer to Section 1, Take-Apart, if necessary.
6. Remove the main logic assembly. Refer to Section 1, Take-Apart, if necessary. **You do not need to remove the memory board, or unscrew the logic assembly from the insulating shield.**
7. Place the logic board on a grounded workbench pad and put on your grounding wriststrap.

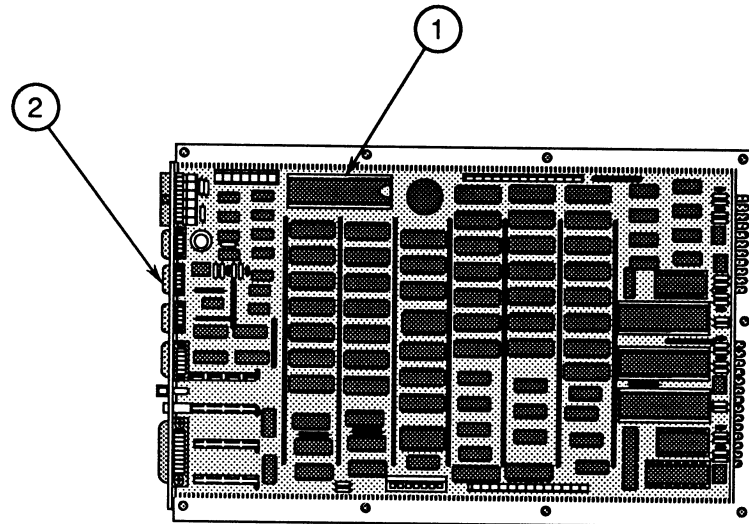

FIGURE 3

8. Locate the keyboard encoder ROM at coordinate J13 (Figure 3, #1) on the main logic board and verify that it is the old ROM (P/N 341-0035).
9. Using an IC extractor, remove the old ROM at location J13 (Figure 3, #1) on the logic board.
10. Install the new keyboard encoder ROM (P/N 341-0136 or 342-0136) at J13 (Figure 3, #1) on the main logic board. The small notch on the ROM should face **away** from the output connectors (Figure 3, #2).
11. Replace the main logic assembly. Refer to Section 1, Take-Apart, if necessary.
12. Remove the keyboard cover and keyboard. Refer to Section 1, Take-Apart, if necessary.
13. Install the Apple III Plus keyboard and keyboard cover. Refer to Section 1, Take-Apart, if necessary.

Apple /// Technical Procedures

Section 5

Apple /// Plus Diagnostics

Contents:

Introduction.....5.3
Diagnostics Setup.....5.3
Diagnostics Menu.....5.3
Make Test Disks (Diskettes).....5.4
RAM Test.....5.5
ROM Test.....5.6
Calendar/Clock Test.....5.6
Disk Test.....5.6
Keyboard Tests.....5.7
Sound Tests.....5.9
Video Tests.....5.10
Test All.....5.13

P. 5.2 blank

A. INTRODUCTION

NOTE: Before using the Diagnostic Diskette, make a backup by using the Device Handling Commands on the System Utilities diskette.

This section describes the function of each of the diagnostic tests and how to run them. You will need a known-good disk drive and a copy of the diskette "Apple /// Plus Dealer Diagnostic Program" (P/N 077-0032). You will also need a blank diskette, to be made into a test diskette, for each disk drive you intend to test.

As you run the diagnostics, some of the messages on the screen will refer to the Apple /// instead of the Apple /// Plus. This message has no significance as long as you are using the correct diagnostic diskette.

This comprehensive diagnostic tests the ROM, RAM, Calendar/clock chip, keyboard, sound and video of the Apple /// Plus. You can run the diagnostic tests at random (except the KEYBOARD TEST which will not run unless one of the other tests is run before it), or in sequence using Test All. When you run the tests one at a time, you are returned to the Main Menu when the test ends or fails. Selecting "Test All" causes one test to run after the other, as long as each test passes. If any test fails or if you have completed all of the tests, you are returned to the Main Menu.

NOTE: Some of the diagnostics will NOT pass unless they are run EXACTLY as specified. Before you run the following diagnostic tests make sure you read ALL instructions FIRST:

Make Test Diskettes

Keyboard tests

Video tests—especially the Interlace test

NOTE: Running the Keyboard test first can cause the system to hang. So before running the Keyboard test, run any other test first (ROM, RAM, etc.).

B. DIAGNOSTICS SETUP

1. Check to see that your Apple /// Plus and all associated peripherals are hooked up properly.
2. Insert the diagnostics diskette into the internal disk drive and boot the system.

3. If the text appears to vibrate, switch the Interlace switch to the off (0) position. (The switch is located on the left side of the computer about halfway back.)

C. DIAGNOSTIC MENU

1. After you have booted the diagnostic program, the following menu is displayed on the monitor.

```
APPLE /// PLUS DEALER TEST

MAIN MENU

TEST ALL

RAM                (NOT TESTED)
ROM                (NOT TESTED)
CALENDAR/CLOCK    (NOT TESTED)
DISK               (NOT TESTED)
KEYBOARD          (NOT TESTED)
SOUND             (NOT TESTED)
VIDEO             (NOT TESTED)

MAKE TEST DISKS

PRESS:  UP/DOWN ARROWS TO SELECT TEST
        RETURN TO RUN TEST
```

NOTE: Because the Apple /// Plus runs several internal diagnostics before booting, coming this far is a vote of confidence for correct system operation.

2. You will notice that TEST ALL is highlighted in inverse video. The inverse video indicates which test will run when RETURN is pressed.
3. UP/DOWN arrows move the inverse cursor line through the list of menu options one-by-one. Pressing RETURN accepts and runs the highlighted option.

D. MAKE TEST DISKS (DISKETTES)

This procedure creates a diskette used for the disk test. You will need one diskette for each drive you are going to test. These test diskettes can be made on any Apple /// Plus system with a known-good disk drive, then used whenever you need to test a disk drive. The known-good disk drive must be configured as Drive 2.

1. Press the down arrow several times until MAKE TEST DISKS is highlighted.
2. Accept this option by pressing the RETURN key.
3. The screen displays:

TEST DISKETTE MAKER

PLACE DISK TO BE FORMATTED IN DRIVE 2

WARNING

DISKETTE DATA IN DRIVE 2 WILL BE ERASED

PRESS ANY KEY TO BEGIN

4. Insert a blank disk into the known-good drive 2. Close the door and press RETURN. The same message remains on the screen during the process.
5. When the test diskette is complete, you will be asked if you want to make another test disk. Pressing "Y" will return you to step 5.
6. If you do not want to make any more test diskettes, press any key other than Y and you will return to the MAIN MENU.

E. RAM TEST

1. To run the RAM test if you have not selected TEST ALL, press the up or down arrow through the Main Menu until RAM TEST is highlighted; then press RETURN.
2. The test first attempts to determine the size of system memory. There are two possible outcomes:
 - a. A screen appears with the correct memory size. Press SPACE BAR and the RAM test starts.
 - b. A screen appears with the wrong memory size. Press RETURN. The test prints "RAM MAP FAILED" and returns to the Main Menu. If this happens run the RAM test again.
3. If the memory size was correctly determined, the test then checks the RAM and reports any failures by their memory board location (e.g., D10, D20.)
4. Upon completion of the test, the Main Menu appears (unless you have selected Test All).

F. ROM TEST

1. Use the up/down arrows until ROM Test is highlighted; then press RETURN.
2. The system takes over and you will see one of two messages:

ROM PASSES . . . or ROM FAILS . . .

3. Upon completion of the test, the Main menu reappears, unless you have selected Test All.

G. CALENDAR/CLOCK TEST

This test checks all functions of the calendar/clock chip. Failures, if encountered, are reported on the monitor. If any part of the test fails, the chip should be replaced.

H. DISK TEST

This option runs a series of tests on each Apple /// Plus drive you wish to test. The drives are tested one at a time. If one fails, the test then restarts for the next drive to be tested. A test diskette is required for each drive you intend to test. (See next page.)

1. Remove the Dealer Diagnostic disk from the internal drive. Then press RETURN to continue.
2. Install the test diskettes, which were made by the "Make Test Disks (Diskettes) procedure, in all drives to be tested.

NOTE: Only test diskettes made with this diagnostic will work for the disk tests.

3. To start the test, press the key (1-4) corresponding to the number of drives you have to test. If you decide not to run the test, press '0'.
4. If a drive fails this or any other test in the series, the system stops testing that drive and starts the series of tests on the next drive.

5. As the tests continue, the screen clears, the system beeps and the following message appears:

```
APPLE /// MODE DISKSWITCH TEST
```

```
REMOVE DISKETTE FROM DRIVE 1  
AND PUT IT BACK IN AGAIN
```

```
PRESS RETURN TO CONTINUE
```

Open the drive door, pull the test disk out from the drive about 1 inch and put it back in. Close the disk door and press RETURN. The test status is briefly displayed and the screen clears. (This switch is used by SOS during some of its operations.)

6. The Disk Track Seek test now starts. Thirty four tracks are displayed on the screen and are alternately tested, from the outermost track to the innermost track, until the middle track is reached. The status of each track is displayed.
7. Disk speed test first reformats track 52 on the test diskette, then checks the DSPEED. A scale between -100 (slow) and +100 (fast) is shown with an arrow pointing to the measured value. The computer beeps if Dspeed is out of spec (+/- 10). If there is no beep, the value is acceptable. The value is displayed until you press the ESCAPE key to continue. The screen then clears and the message:

```
- RESTORING TEST DISKETTE -
```

is displayed. Do NOT turn the power off or open the drive door while the restoring procedure is in progress: if you do, it will destroy the test diskette. If there are other drives to be tested, steps 5 thru 6 repeat. When all drives have been tested the Main Menu reappears (unless the Test All option was selected, in which case the next test starts.)

I. KEYBOARD TESTS

The keyboard test is divided into 4 sections:

1. Alphanumeric Keys
2. Special Function Keys
5. Numeric Keypad Keys
4. Keyboard Interrupt

There is a delay after each section and any special instructions are shown on the monitor at the beginning of each section.

NOTE: Some parts of this test will always fail UNLESS you follow the directions exactly. Read ALL directions carefully before running the Keyboard Tests. **NOTES** in each section alert you to special procedures.

1. Alphanumeric Keys

- a. Every alphanumeric keystroke possible is displayed.
- b. Press each key and verify that the corresponding letter or number on the screen is removed.

NOTE: Press the SPACE BAR LAST. Otherwise, the next test will not automatically start. Pressing the space bar twice might cause the test to fail.

- c. You will need to use a combination of keys to remove three of the keys:

Control "A" for CONTROL
Shift "2" for left shift and
Shift "=" for right shift.

2. Numeric Keyboard Test

- a. The keys on the numeric keyboard are displayed.
- b. Press each key and verify that the corresponding number on the screen is removed.

NOTE: You can abort this test any time by pressing ESCAPE. The test will record a failure if it is aborted.

- c. After you have removed all of the keys displayed on the monitor, the next test automatically starts.

3. Special Function Keys

NOTE: If you hold the keys down too long, this test might fail.

- a. After the special function keys are displayed, press the CAPS LOCK (ALPHA LOCK) key once. This tests the CAPS LOCK key.

NOTE: If the Caps Lock key was in the up position, pressing it once puts it in the down position. Leave it in whatever position it is in after pressing it ONCE, or the test will fail.

- b. The diagnostic then asks you to press the SPACE BAR and hold it down. This tests the slow repeat function. Continue holding the Space Bar down, in order to complete the next step.
- c. Simultaneously press the SOLID APPLE and OPEN APPLE keys while continuing to hold the Space Bar down. This tests the OPEN APPLE key and the fast repeat function.
- d. Release all the keys. Now press the SOLID APPLE key first and then the SPACE BAR. This tests the repeat inhibit function. Release these keys when you see the message Keyboard Interrupt Test.

4. Keyboard Interrupt Test

When the keyboard interrupt test comes up on the screen, simply press any key to continue. The keyboard pass/fail status is given, and then the Main Menu appears, unless Test All has been selected.

J. SOUND TESTS

The SOUND diagnostic test has 5 parts: a soft bell, a loud bell, and a sound that gradually grows from soft to loud and then repeats. Use the up/down arrows to select the Sound Tests. After each part:

PRESS SPACE BAR IF YOU HEAR THE SOUND

PRESS RETURN IF YOU DON'T

Upon completion of the test, the pass/fail status is shown. You are then returned to the Main Menu unless Test All was selected.

K. VIDEO TESTS

There are several video tests which check the color shades and the different modes in which the monitor can operate. You will be shown a test pattern and asked to indicate what you observe. What you enter will determine whether the system records a pass or fail for the test.

NOTE: The last test checks the Interlace switch. When you see a horizontal white line on the screen, **STOP** and read the directions for this test. (See the last page of this document.)

1. At the beginning of each video test the screen briefly displays the name of the test and tells you which keys to press to indicate if what you saw was what was expected. Many of the tests use the same test pattern. Usually a picture of Winston Churchill appears in the upper-left corner. A grid of diagonal lines appears in the upper-right corner. The lower-half of the screen displays the following message in LARGE letters:

If you can read this, and
the test patterns above
are clear, press space bar.
Otherwise, press return.

2. Some displays fill the entire screen. If the display shows what it is supposed to (see the table on the following pages), press SPACE BAR to continue. If the display does not show what it was supposed to, press RETURN.
3. Between patterns the following message flashes:

TYPE SPACE BAR TO ACCEPT

TYPE RETURN TO REJECT

TYPE ESCAPE TO ABORT

NOTE: With a black-and-white monitor, different colors will be displayed as different shades of grey; some black-and-white monitors are not capable of displaying all the different shades with a single setting of the monitor controls. Do not reject the monitor for this reason.

4. The next two pages give the names of the video tests and describe the patterns which should appear on the monitor.

VIDEO TESTS AND PATTERNS

TEST DISPLAY	B&W MONITOR	COLOR MONITOR
APPLE II HIRES MODE PAGE 1	B&W Pattern only	No Color
APPLE II HIRES MODE PAGE 2	B&W Pattern only	No Color
280 x 192 COLOR HIRES MODE PAGE 1	Negative image	Red and Black
280 x 192 COLOR HIRES MODE PAGE 2	B&W Pattern	Green & White/ or Yellow
SUPER HIRES TEST PAGE 1	B&W Pattern only	No Color
SUPER HIRES TEST PAGE 2	B&W Pattern only	No Color
AHIRES COLOR TEST PAGE 1	Pattern divided into 4 different shades of grey.	Top to bottom, pattern is: violet (pink), blue, green, & gold (orange).
AHIRES COLOR TEST PAGE 2	Pattern divided into 4 different shades of grey.	Top to bottom pattern is: violet (pink), blue, green, & gold (orange)
COLOR BAR & GREY SCALE TEST	16 shades of grey from white on left to black on right--- may be difficult to resolve.	16 shades left to right white, aqua, yellow, green, pink, orange, brown, light blue, medium blue, grey, dark green, light purple, dark blue, magenta and black
APPLE II TEXT MODE PAGE 1	Sentence and alphabet are displayed.	Same as B&W

```
=====
TEST DISPLAY           B&W MONITOR           COLOR MONITOR
=====
```

APPLE II TEXT MODE page 2. This screen will display for both B&W and color:

```

22222222222222222222222222222222
22222222222222222222222222222222
22222222222222222222222222222222
                222
                222
                222
22222222222222222222222222222222
22222222222222222222222222222222
22222222222222222222222222222222
222
222
222
22222222222222222222222222222222
22222222222222222222222222222222
22222222222222222222222222222222

```

```
=====
APPLE ///           16 blocks different           16 colored
40 COLUMN           shades of grey, with           blocks, color
TEXT MODE           color names printed           names printed
                    in each box.                   in each box.

```

The colors are:

BLACK	MAGENTA	DARK BLUE	LIGHT PURPLE
DARK GREEN	GREY	MEDIUM BLUE	LIGHT BLUE
BROWN	ORANGE	GREY	PINK
GREEN	YELLOW	AQUA	WHITE

```
=====
APPLE ///           smaller characters           same as B&W
80 COLUMN           across 80 columns
TEXT MODE
=====
```

"_64.PICT" 389 KB 2001-08-25 dpi: 600h x 600v pix: 4720h x 6275v

5. Video Interlace Test.

NOTE: The Interlace switch is located on the left side of the computer halfway back.

There are two displays used for this test. After seeing the first display (a horizontal white line across the center of the screen), flip the interlace switch to see the other display. The second display is a horizontal and a vertical which cross at the center of the screen.

- a. If the display is not altered when you change the switch position, press RETURN to tell the system that the test failed.
- b. If you can see BOTH displays, one display for each switch position, then press the SPACE BAR to PASS the test.

6. At the end of the Interlace Test turn the Interlace switch to the OFF (0) position.

L. TEST ALL

Accepting this option runs all the tests sequentially. After each test is run you are returned to the main menu where "passed" or "failed" is highlighted. The tests that run are:

RAM
ROM
CALENDAR/CLOCK
DISK
KEYBOARD
SOUND
VIDEO

NOTE: Before running **Test All**, follow the procedure "Make Test Disks (Diskettes)", to make a test diskette for each drive you will test.

1. Skip through the tests using the up/down arrow until TEST ALL is highlighted.
2. Accept this option by pressing RETURN.
3. As each test runs, messages appear on the monitor to tell you what test is running. In some cases you will be asked to enter a response, depending upon what you observe as the test runs. Other tests run automatically and only the results are shown before the next test runs.

🍏 Apple Technical Procedures

Apple III and Apple III Plus

Section 6 – Illustrated Parts List

□ CONTENTS

- 6.3 Finished Goods Assembly (Figure 1)
- 6.5 Universal Parallel Printer Board (Figure 2)
- 6.5 Logic Board (Figure 3)
- 6.5 Memory Board (Figure 4)
- 6.7 ProFile Interface Card (Figure 5)

The figures and lists in this section include all piece parts that can be purchased separately from Apple for the Apple III, along with their part numbers. These are the only parts available from Apple. Refer to your *Apple Service Programs Manual* for prices.

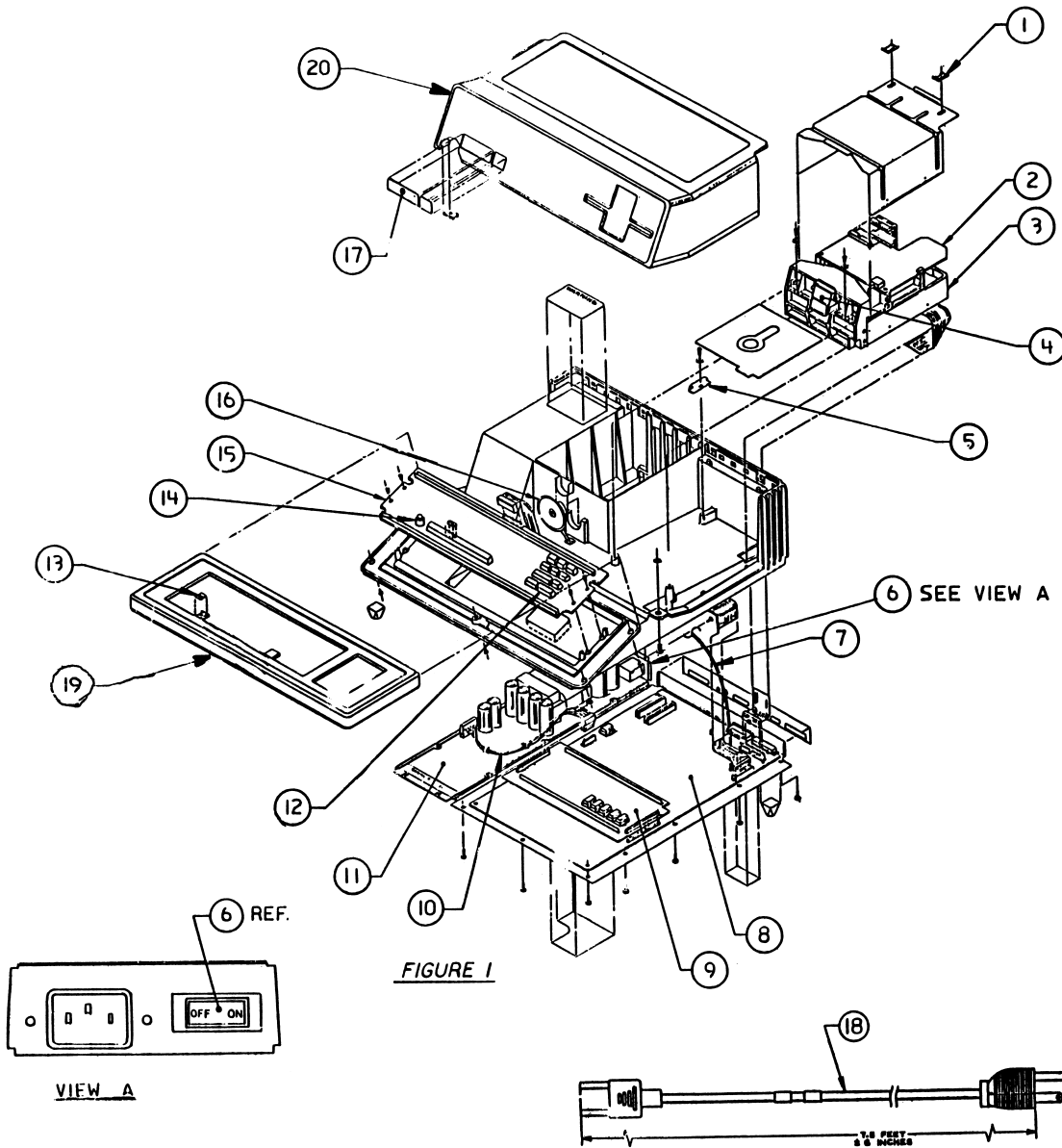

**□ APPLE III AND APPLE III PLUS – FINISHED-GOODS ASSEMBLY
(FIGURE 1)**

<u>Item</u>	<u>Part No.</u>	<u>Description</u>
1	830-0014	Retaining Clip Fastener
2	661-92002	Apple III Disk Analog Card
3	661-92014	Apple III Internal Disk Mechanical Assembly
4	815-0162	Disk Door Clip
5	805-0057	Clip, Disk Hold Down
6	705-0010	Switch, Rocker SPST with ON/OFF Legend
7	590-0032	Cable, Keyboard Apple III
8	661-91069	Apple III Logic Board 5 V
	661-91122	Apple III Plus Logic Board 5 V
9	661-91124	Apple III Memory Board w/RAM
10	590-0017	Cable, Power Supply to Apple III Logic Board (10-pin-to-10-pin connector)
	590-0118	Cable, Power Supply RFI Apple III Plus (10-pin-to-11-pin connector)
11	661-71125	Power Supply, Apple III, Apple III Plus*
12	658-7041	Apple III Plus Keycap Set
13	825-0163	Label, Power-On Lens
14	710-0007	Apple III Lamp
15	661-91022	Apple III Keyboard
	661-95127	Apple III Plus Keyboard
16	600-0009	Speaker Assembly
17	825-0054	Apple Nameplate
18	590-0003	AC Power Cable
19	815-0087	Keyboard Cover, Apple III
	815-0719	Keyboard Cover, Apple III Plus
20	815-0086	Housing—Apple III, Apple III Plus

* Power supply 661-71125 has an 11-pin connector. To use this power supply, you will need cable 590-0118 (with a 10-pin-to-11-pin connector).

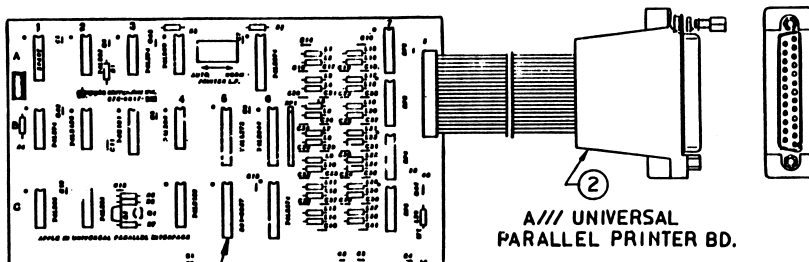

FIGURE 2

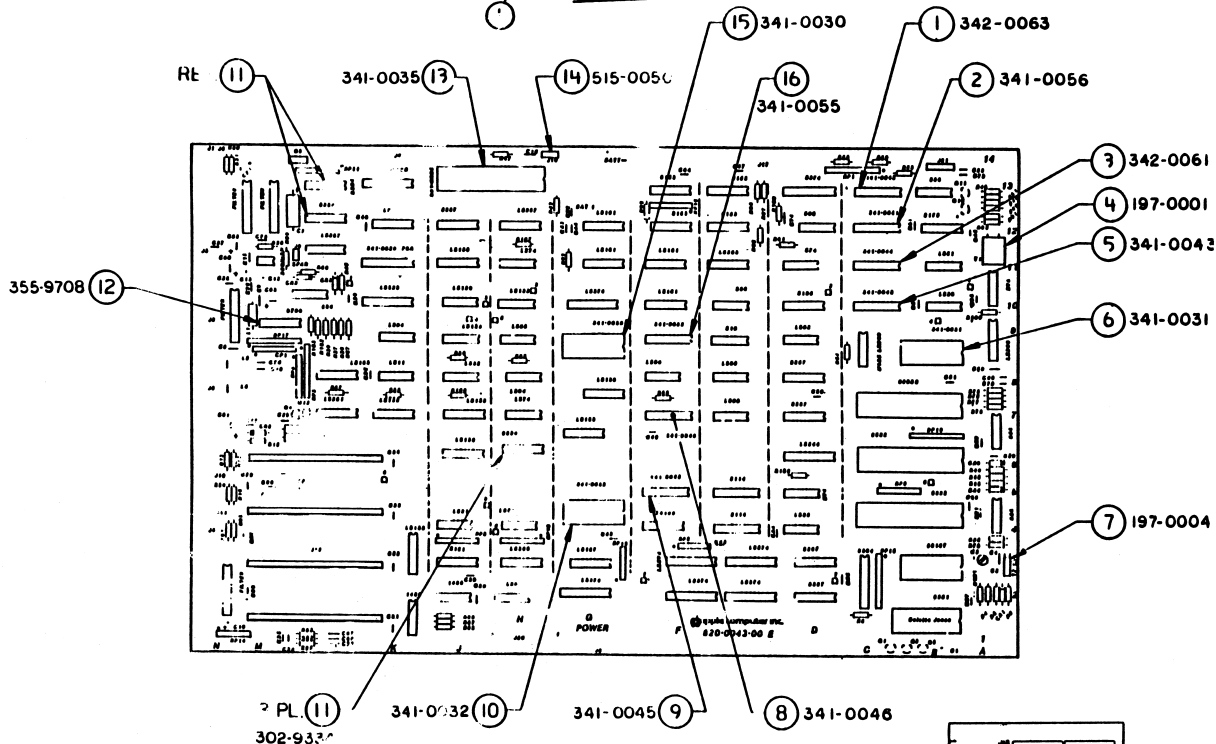

FIGURE 3

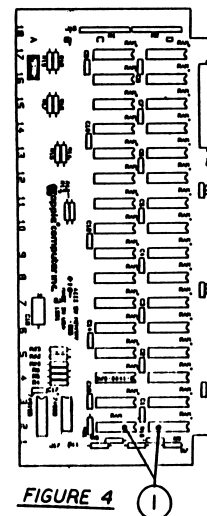

FIGURE 4

APPLE /// and APPLE /// PLUS - UNIVERSAL PARALLEL PRINTER BOARD (Figure 2)

Item	Part No.	Description
1	341-0057	ROM, Parallel Printer Boards
2	590-0128	Cable, Parallel I/F Adapter

APPLE /// and APPLE /// PLUS - LOGIC BOARD (Figure 3)

1	342-0063	IC, PROM CASB256
2	341-0056	IC, PROM CASB65.1
3	342-0061	IC, PROM RAS65
4	197-0001	Crystal, 14.318630 MHz
5	341-0043	PROM, 1024 x 4 U174
6	341-0031	ROM, Boot
7	197-0004	Crystal, Tuning Fork 32.768 KHz
8	341-0046	PROM, 1024 x 4 U180
9	341-0045	PROM, 1024 x 4 U176.2
10	341-0032	ROM, Video Control
11	302-9334	IC, 9334
12	355-9708	IC, 9708 6-CH. 8 Bit A to D
13	341-0035	ROM, Keyboard Encoder
14	515-0050	Three-pin Molex Connector
15	341-0030	ROM Synchrom
16	341-0055	IC, PROM U175-65

APPLE /// and APPLE /// PLUS - MEMORY BOARD (Figure 4)

1	334-0003	IC RAM 64K 200NS w/ Logo
---	----------	--------------------------

Pictures of the following keyswitches and accessories can be found in **Appendix A:**

705-0009	Reset Keyswitch
705-0012	Arrow Keyswitch
705-0015	Alps Short Stem Keyswitch
705-0070	Alps Long Stem Keyswitch
705-0077	Alps Alpha Lock Keyswitch
815-0772	Straight Adapter

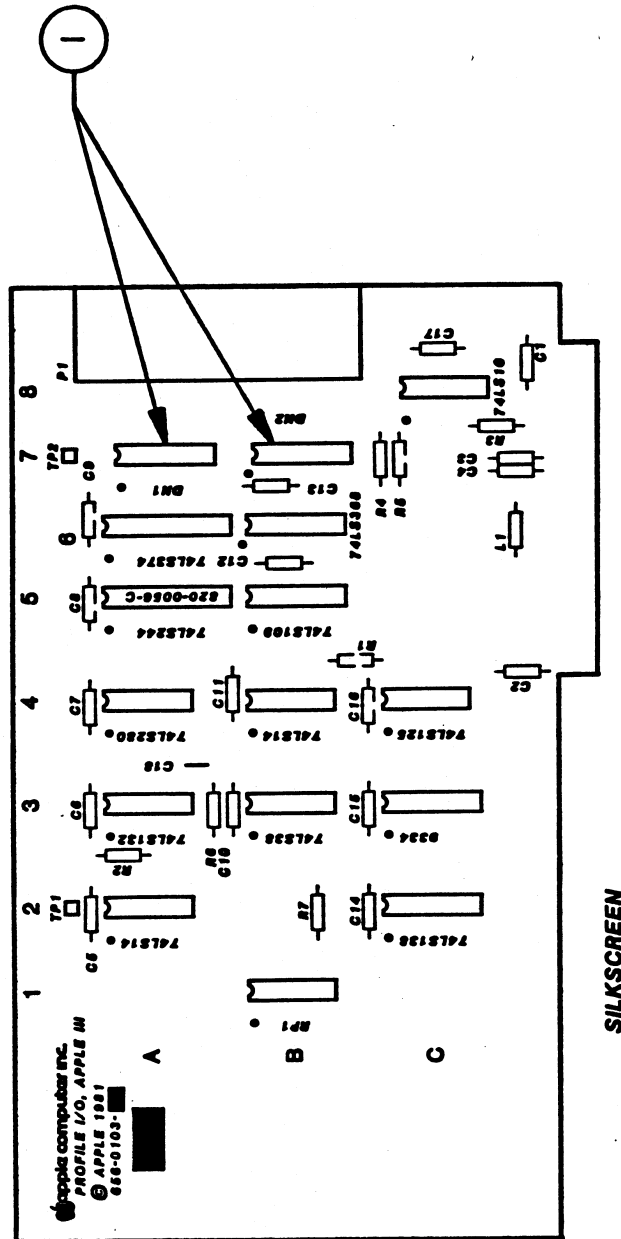

FIGURE 5

**APPLE /// & APPLE /// PLUS - PROFILE INTERFACE CARD
(Figure 5)**

Item	Part No.	Description
1	661-92050 112-0107	ProFile Interface Card Resistor Array, 8 x 100 ohms

Apple /// Technical Procedures

Appendix A

Keyboard and Keyswitch Identification

The Apple /// and /// Plus keyboards have different layouts and are not interchangeable. However, many of the keyswitches on both boards are identical.

The keyswitches used for the Apple /// and /// Plus keyboards are the same, except that the Apple /// Plus uses only the Alps long stem keyswitch. Keyswitch/Keyboard information for the Apple /// can be found in Figure 1, page A.2. Keyswitch/Keyboard information for the Apple /// Plus can be found in Figure 2, page A.3.

NOTE: The procedure to replace a keyswitch is in Section 3 of "You Oughta Know...".

FIGURE 1: Apple III Keyboard

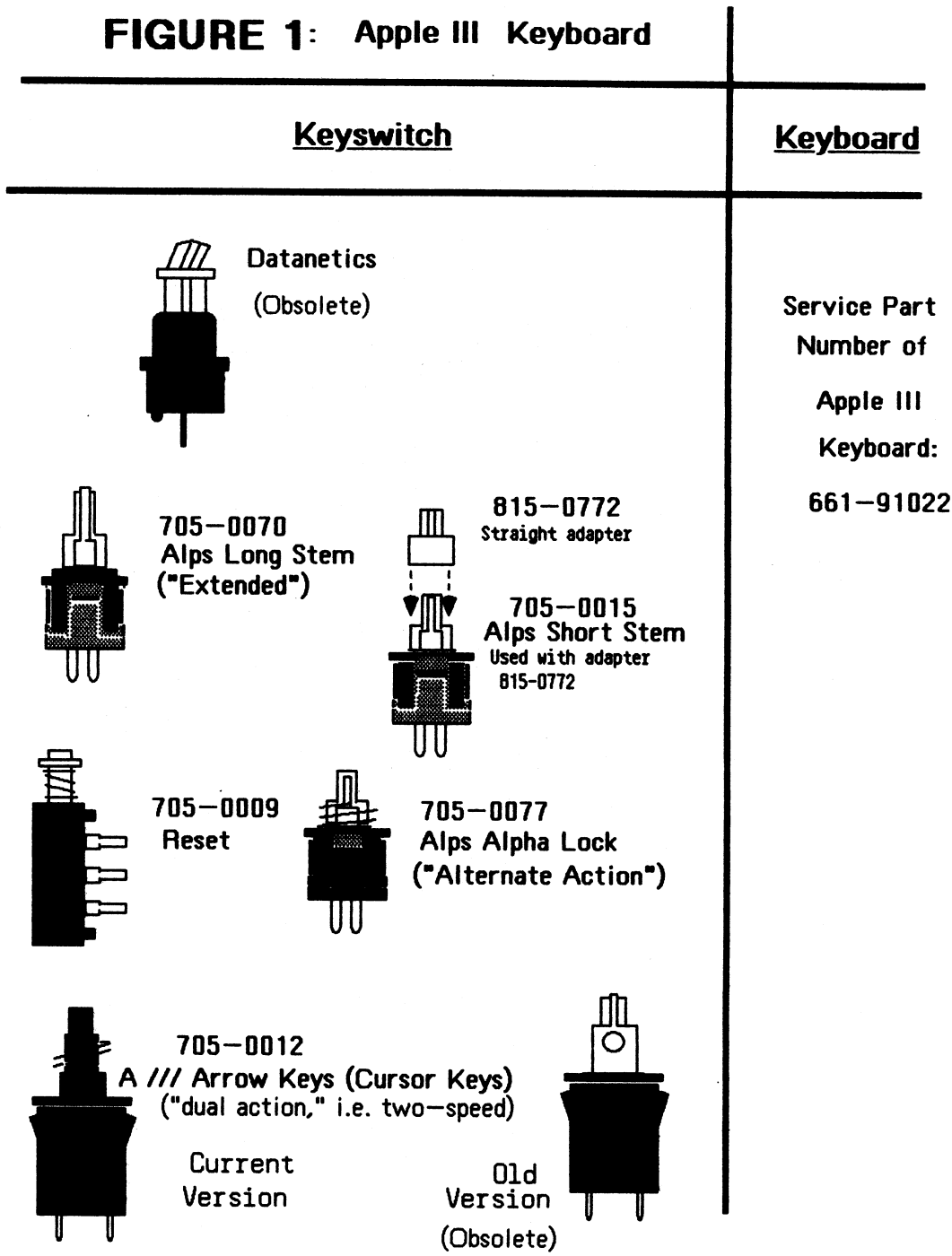
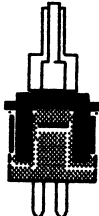
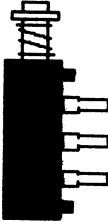

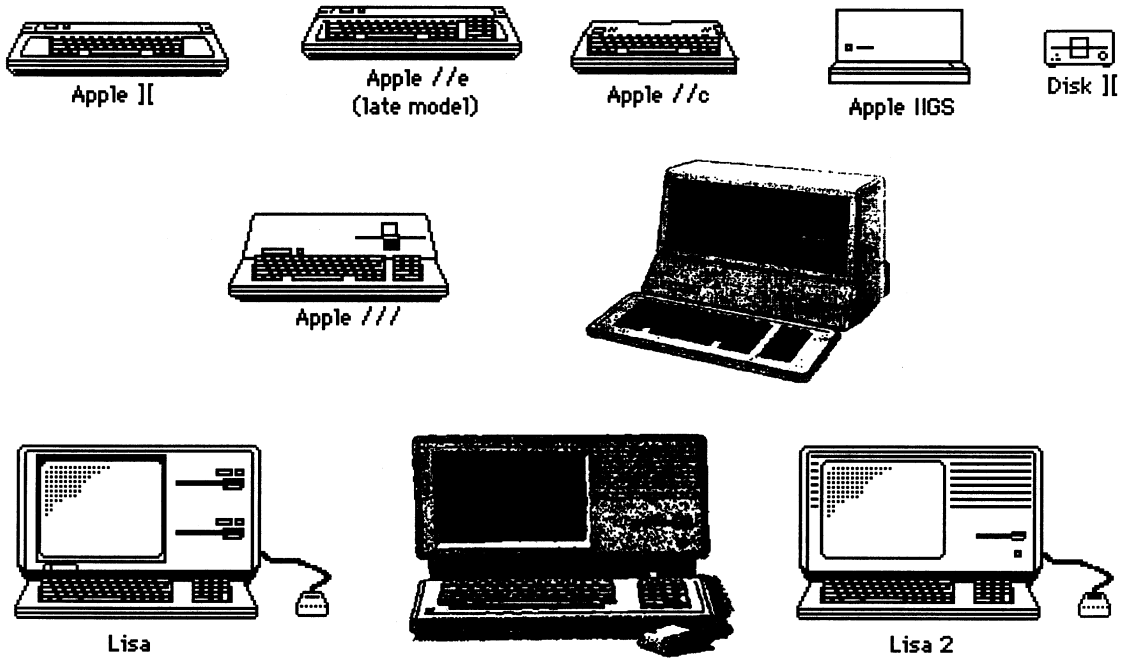

FIGURE 2: Apple III Plus Keyboard

<u>Keypresswitch</u>	<u>Keyboard</u>
 <p>705-0070 Alps Long Stem ("Extended")</p>	Service Part Number of Apple III Keyboard: 661-95127
 <p>705-0009 Reset</p>  <p>705-0077 Alps Alpha Lock ("Alternate Action")</p>	
 <p>705-0012 A /// Arrow Keys (Cursor Keys) ("dual action," i.e. two-speed)</p>	



End of Apple Service Repair Information

