

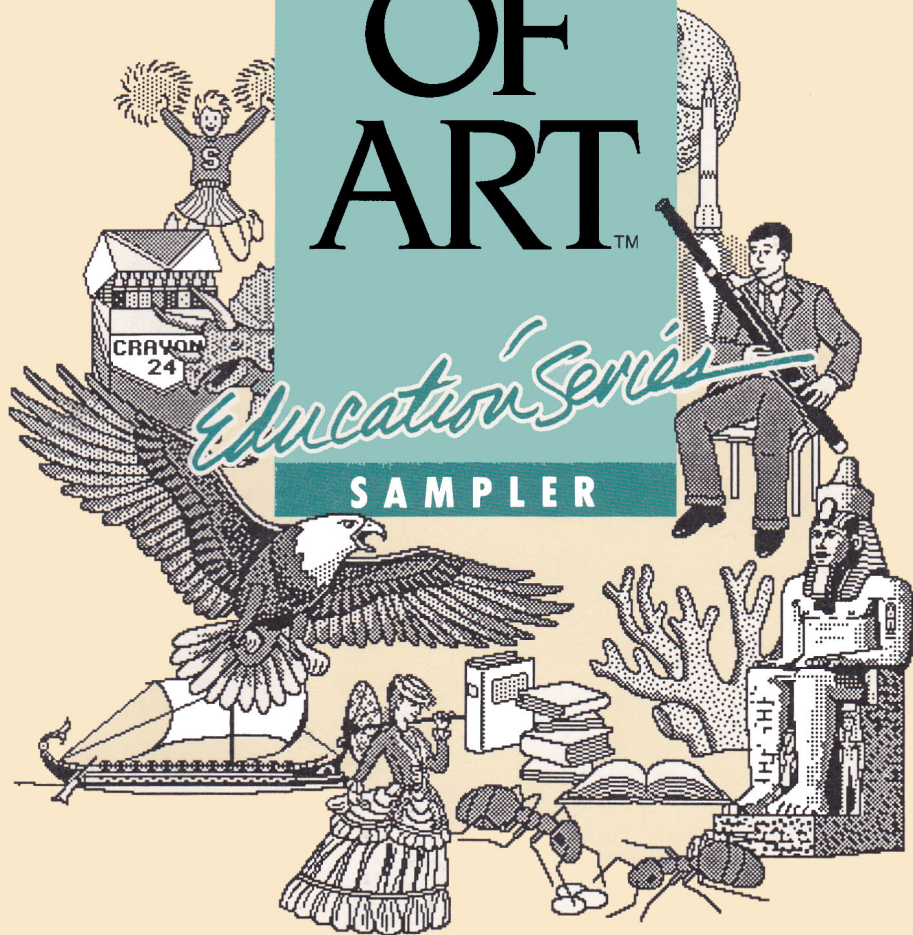

WORKS OF ART™

Education Series

SAMPLER



WORKS OF ART™

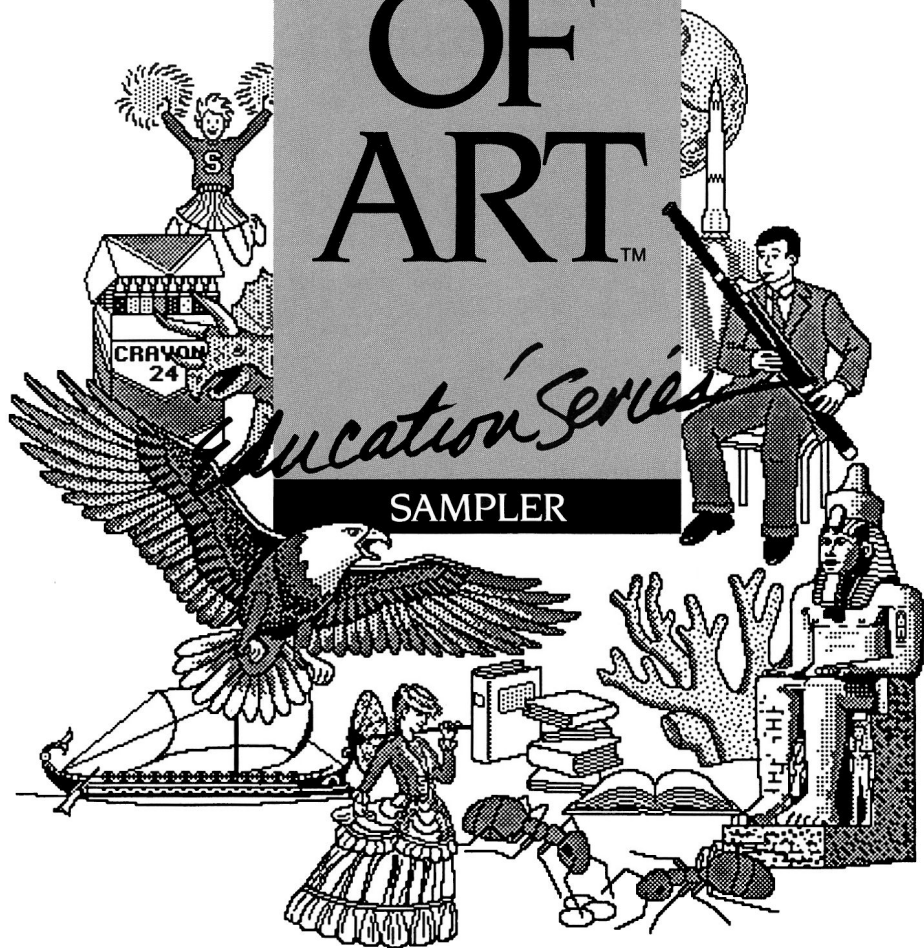

Education Series

SAMPLER

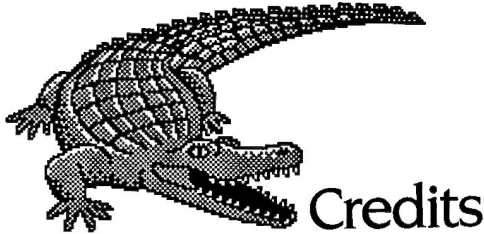

Art Director
Robert Cavey

Artists
Karen Christiansen
Jerry Cratsenberg
Martin Harris
Richard Nielsen
Janice Perry
Victor Raines

Software Technicians
Mark Schneider
Mark Larson
Paul Meyer

©1987 Springboard Software, Inc.

This manual and the software it describes may not be reproduced, in whole or in part, in any form whatsoever, without the written permission of Springboard Software, Inc. Works of Art illustrations cannot be used for any commercial products without the written consent of Springboard Software, Inc.

Springboard Software, Inc.
7808 CreekrIDGE Circle
Minneapolis, MN 55435

Springboard Publisher and Works of Art are trademarks of
Springboard Software, Inc.

Apple is a registered trademark of Apple Computer, Inc.

Customer Support Hotline
612-944-3912

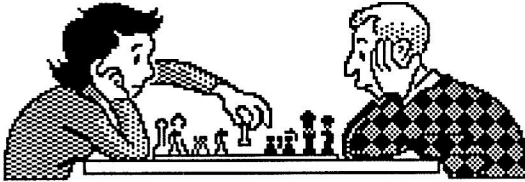

Table of Contents

4	Welcome
5	Instructions
7	Art Catalog
57	Tell us what you like
59	Limited Warranty



Welcome

The *Works of Art™ Education Series Sampler* takes you on an adventure in learning. Inside you'll discover over 500 superb illustrations which cover a wide variety of subjects. You'll enjoy using this artwork to illustrate your reports, create exciting classroom handouts or club fliers. Even if you aren't in school you'll find this package of art impressive and fun to use.

This manual explains step by step how to import artwork into your documents. In addition, the catalog section lists the art categories and shows the art at actual size. The catalog makes it easy to select the piece of art you want to use. (The size of the art may vary slightly, depending on your brand of printer. All art in this manual was printed on a laser printer in draft mode.)

The artwork is organized into categories and arranged on "pages." The page names that you see in this manual are the same as the ones you will see in the Import Graphics command of Springboard Publisher.™ They are in alphabetical order for easy access. Some artwork, such as the dinosaurs on page 17 in this manual is labeled to help you identify each individual piece of art. The labels appear only in this manual; they are not part of the artwork.

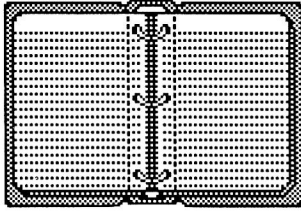

Instructions

You can import artwork from this disk using the same procedure that you have used to import artwork from the Springboard Publisher master program disk. There are two ways to import artwork into a Springboard Publisher document:

- You can select an existing graphics frame and then import the artwork into that frame.
- or
- You can have the program create a new frame for the imported artwork.

The step-by-step instructions below assume that you already know how to use the Springboard Publisher program. See the Springboard Publisher *Getting Started* and *Reference* manuals if you need help in operating the program.

1. Look in this booklet to find the piece of artwork you want. Remember the page name.
2. If you want to import the artwork into an existing graphics frame, select that frame by clicking in it. If you want the program to create a frame for the artwork, then make sure that no graphics frame is selected.
3. Choose the Import Graphics command from the  menu.
4. Replace the program disk with the *Works of Art* disk, then click the New disk button.

5. From the list of page names, click on the desired name, then click Open. Use the scroll bar, if necessary, to reveal more page names.
6. If you want one entire piece of artwork, double-click on that piece. If you want only part of a piece or if you want two or more pieces, drag the pointer so that it encloses the artwork you want. If you chose the wrong page by mistake, click the Close box or press Esc.
7. Choose the Copy (⌘-C) command from the Edit menu. The program closes the page of art and returns to your document.
8. Choose the Paste (⌘-V) command from the Edit menu. The program puts the artwork into your document.
9. Put the pointer on the artwork, if desired, and drag the artwork to its final location.

WORKS OF ART™

Education Series

SAMPLER

Catalog

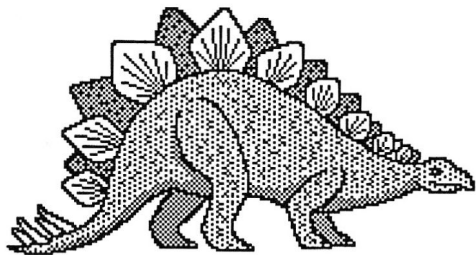

WORKS OF ART™
Education Series Sampler
Art Categories

Anatomy1	History2	Maps2	Money1
Anatomy2	History3	Maps3	Music1
Artists1	History4	Maps4	Music2
Astronomy1	History5	Maps5	Plants1
Birds1	History6	Maps6	Preschool1
Dinosaurs1	Insects1	Maps7	Reptiles1
Fish1	Inventions1	Maps8	Science1
Government1	Inventions2	Meteorology1	Shop1
Headings1	Literature1	Misc1	Supplies1
Headings2	Mammals 1	Misc2	Supplies2
History1	Maps1	Mollusks1	Tools1

Anatomy1

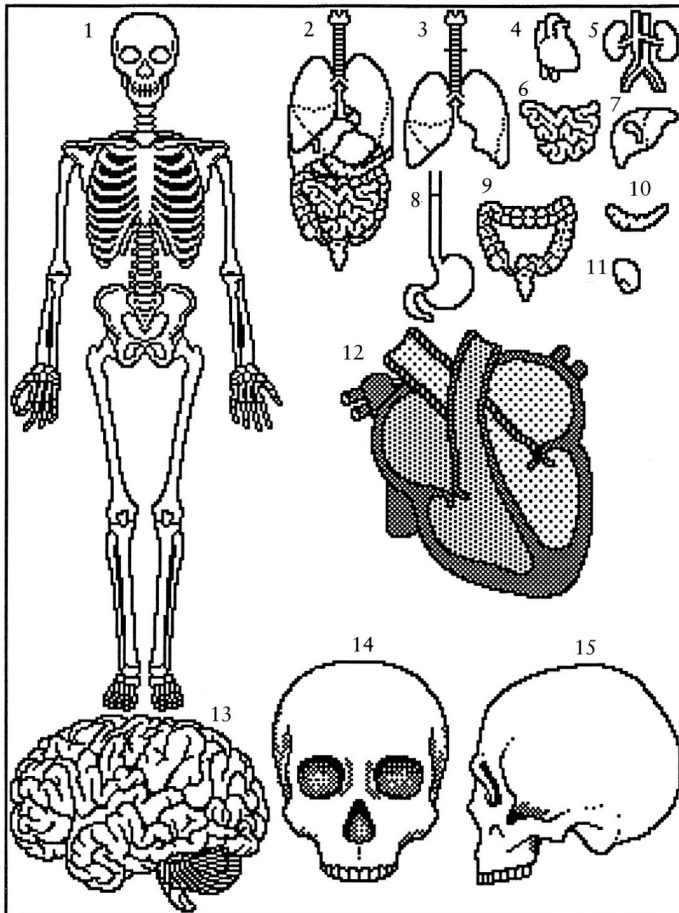

1. Human skeleton
2. Human organs
3. Lungs, windpipe and thyroid cartilage
4. Heart
5. Kidneys
6. Small intestine
7. Liver and gall bladder

8. Stomach, duodenum, outlet
9. Large intestine
10. Pancreas
11. Spleen
12. Heart
13. Brain
14. Skull
15. Skull

Anatomy1: Brain in detail

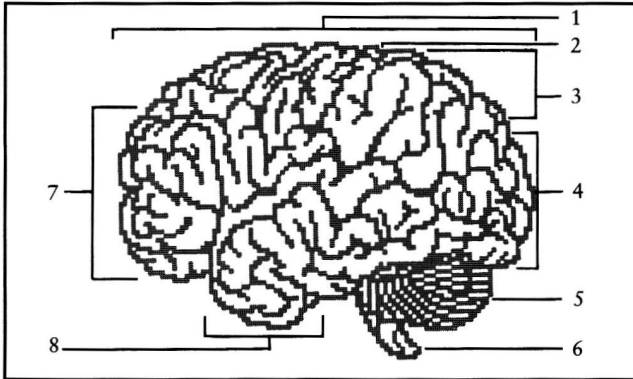

- 1. Cerebral hemisphere
- 2. Central fissure
- 3. Parietal lobe
- 4. Occipital lobe

- 5. Cerebellum
- 6. Medulla oblongata
- 7. Frontal lobe
- 8. Temporal lobe

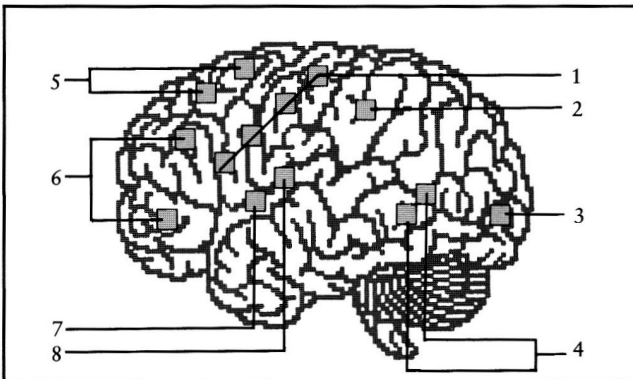

- 1. Body movements
- 2. Understanding
- 3. Vision
- 4. Perception

- 5. Facial movements
- 6. Thought
- 7. Hearing
- 8. Speech

Anatomy2

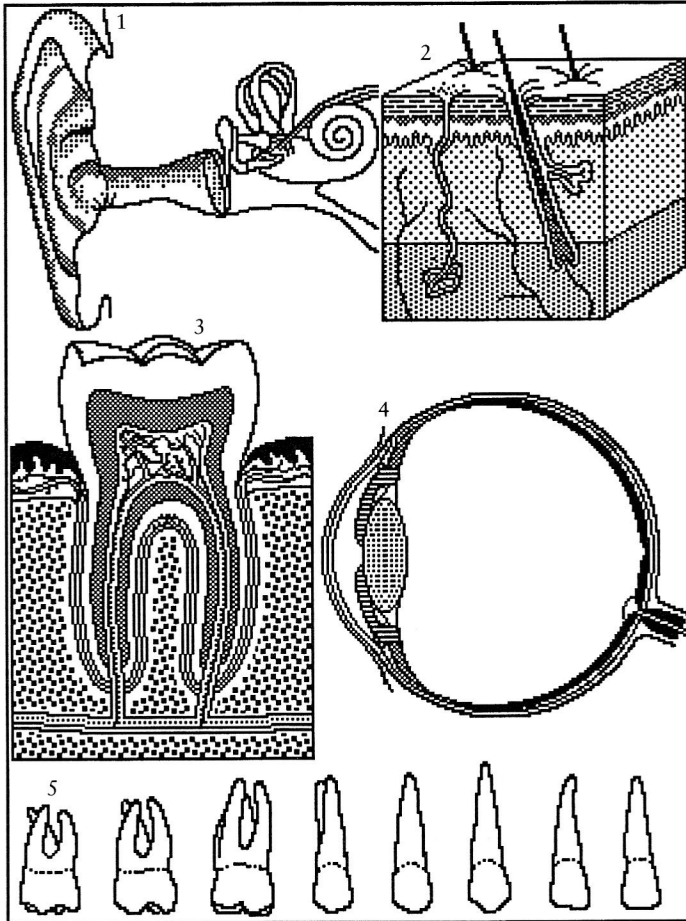

1. Ear and inner ear
2. Cross-section of human skin
3. Cross-section of molar

4. Cross-section of human eye
5. Teeth

Anatomy2: in detail

Ear and inner ear

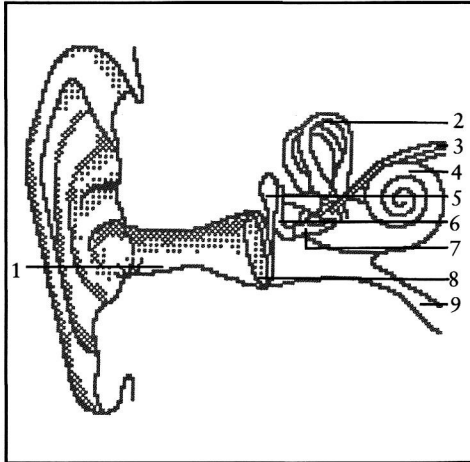

1. Ear canal
2. Semicircular canals
3. Auditory nerve
4. Cochlea
5. Hammer
6. Anvil
7. Stirrup
8. Eardrum
9. Eustachian tube

Cross-section of molar

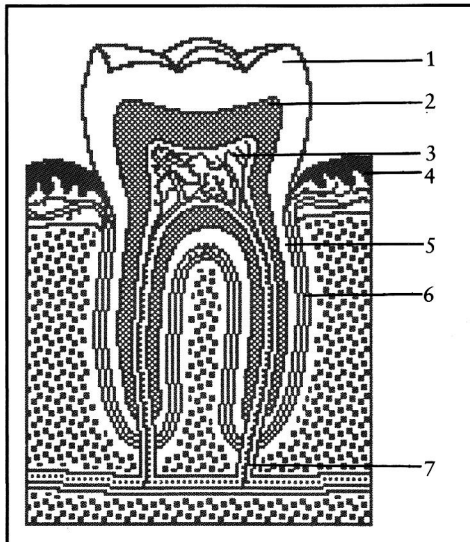

1. Enamel
2. Dentin
3. Pulp
4. Gum
5. Cementum
6. Periodontal membrane
7. Blood vessels and nerves

Cross-section of human eye

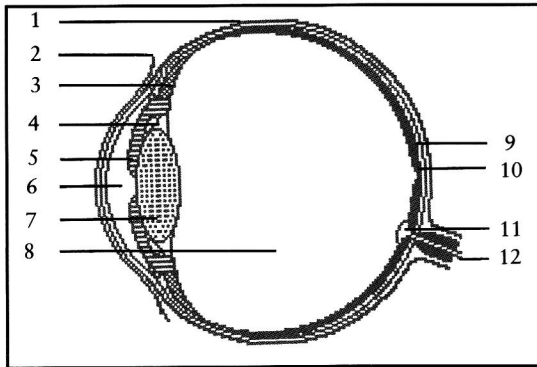

1. Sclerotic coat
2. Conjunctiva
3. Ciliary muscle
4. Suspensory ligament
5. Iris
6. Pupil
7. Lens
8. Vitreous body
9. Retina
10. Fovea
11. Blind spot
12. Optic nerve

Cross-section of human skin

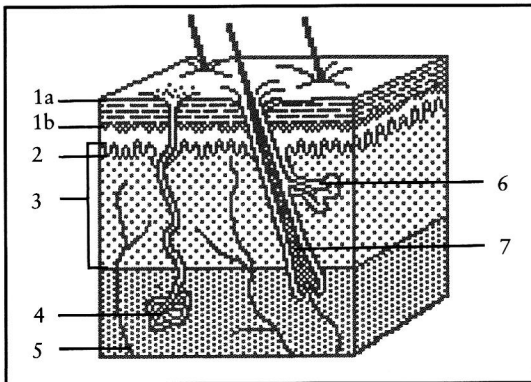

1. Epidermis
 - a. Dead cells
 - b. Producing cells
2. Papillae
3. Dermis
4. Sweat gland
5. Blood vessel
6. Sebaceous gland
7. Hair

Teeth

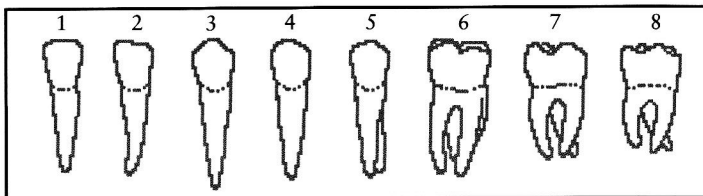

- | | |
|-----------------|--------------------|
| 1. Wisdom tooth | 5. Premolar |
| 2. Molar | 6. Canine |
| 3. Molar | 7. Lateral incisor |
| 4. Bicuspid | 8. Middle incisor |

Artists1



Astronomy1

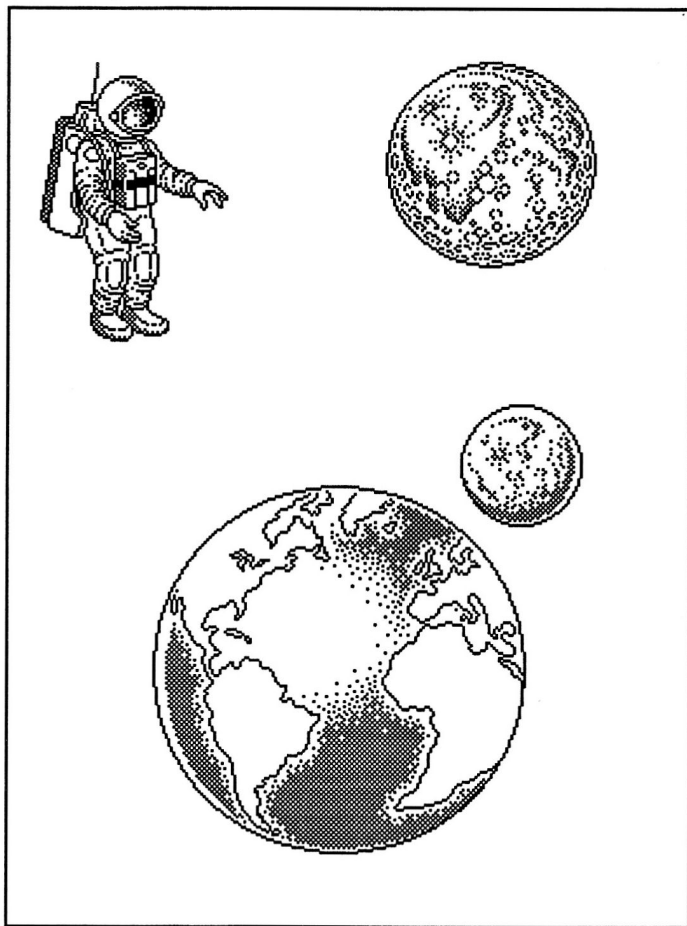

Birds1

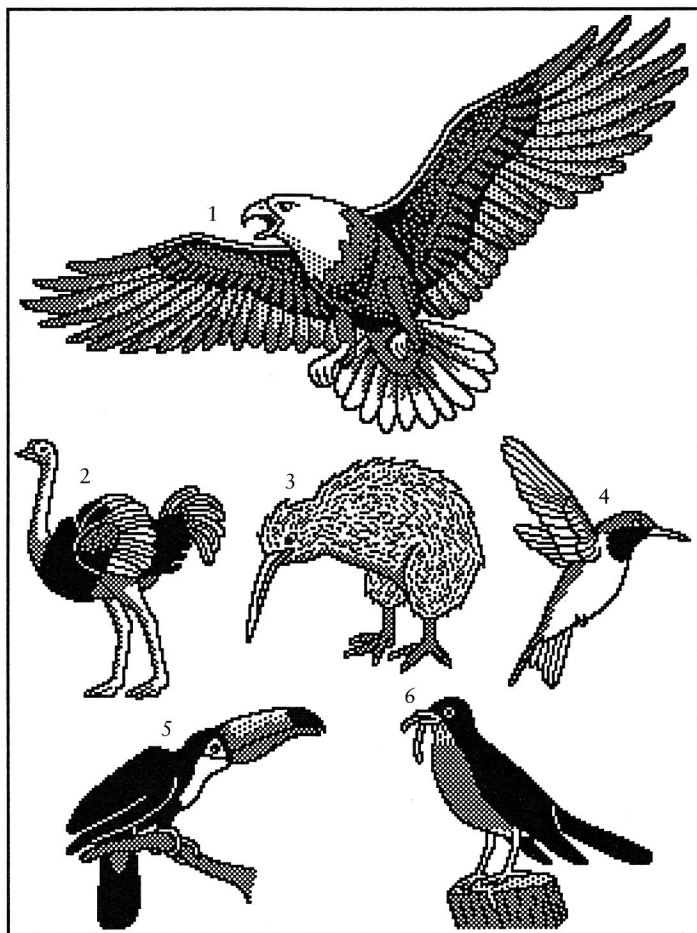

1. Bald eagle
2. Ostrich

3. Kiwi
4. Hummingbird

5. Toucan
6. Robin

Dinosaurs1

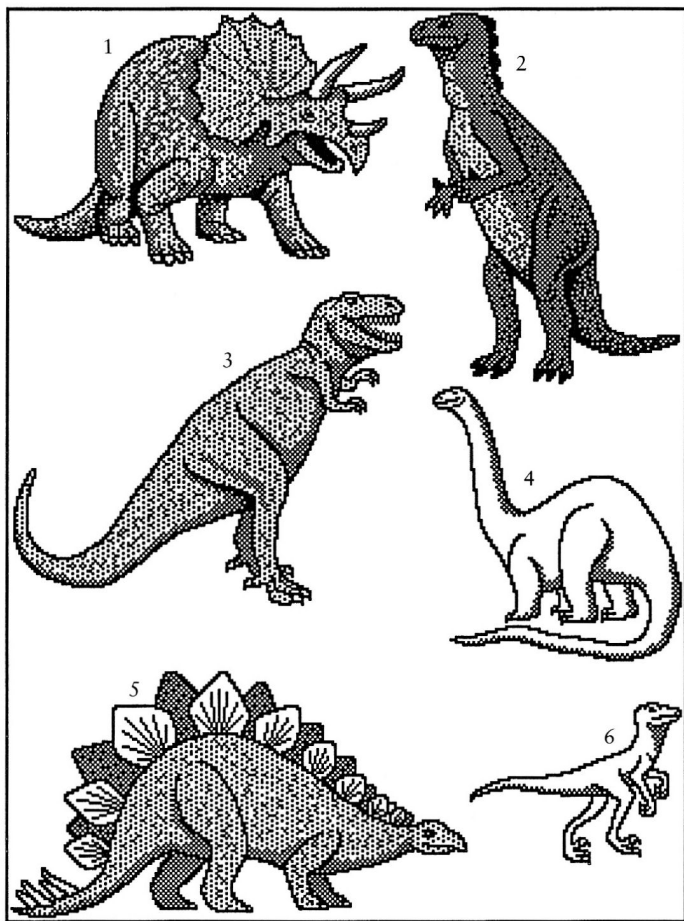

1. Triceratops
2. Iguanodon

3. Tyrannosaurus
4. Apatosaurus

5. Stegosaurus
6. Deinonychus

Fish1

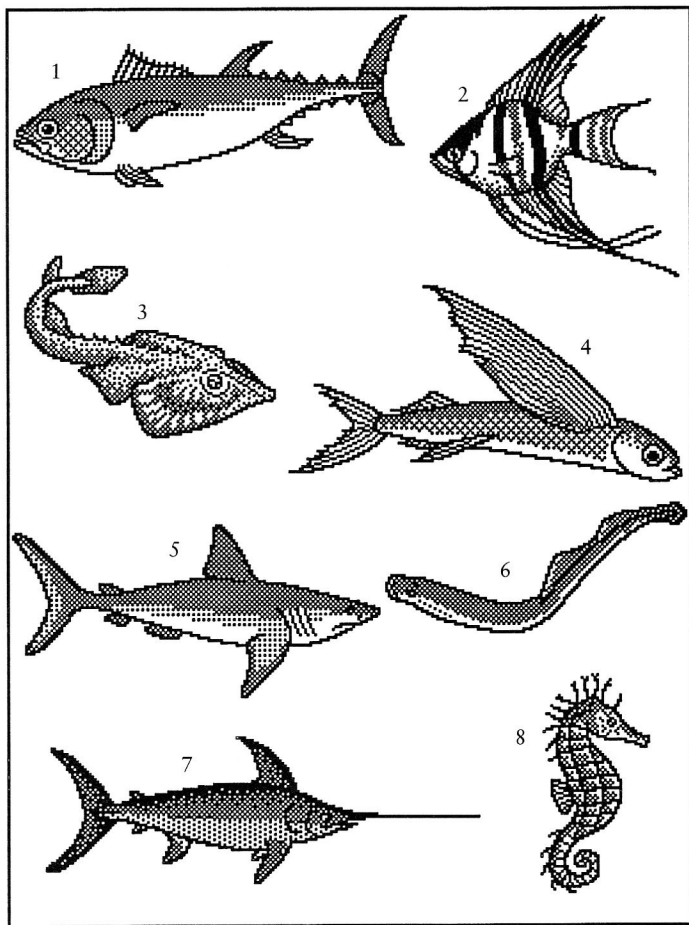

1. Bluefin tuna
2. Angelfish
3. Shovelnose guitarfish
4. Atlantic flying fish

5. Porbeagle shark
6. Sea lamprey
7. Swordfish
8. Sea horse

Government 1

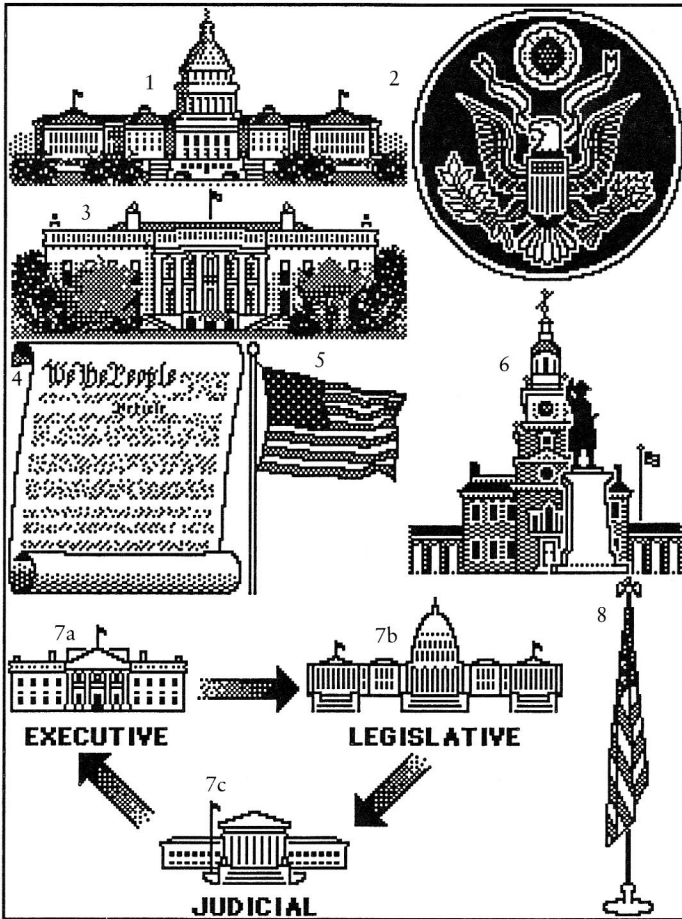

1. U.S. Capitol
2. U.S. Presidential Seal
3. White House
4. U.S. Constitution
5. U.S. Flag
6. Independence Hall

7. The three branches of government
 - a. White House
 - b. U.S. Capitol
 - c. The Supreme Court building
8. U.S. Flag

Headings1

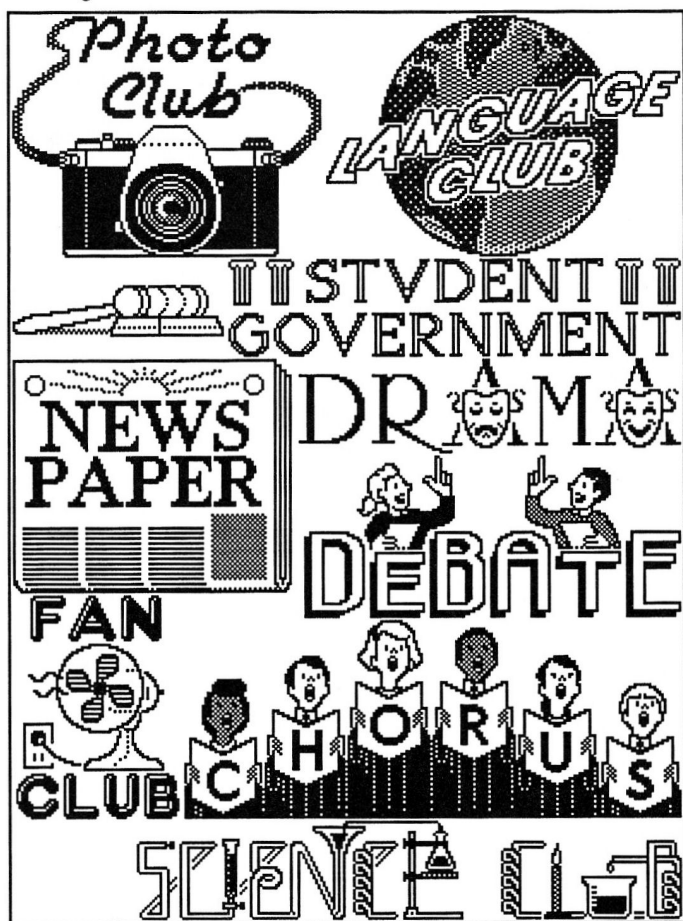

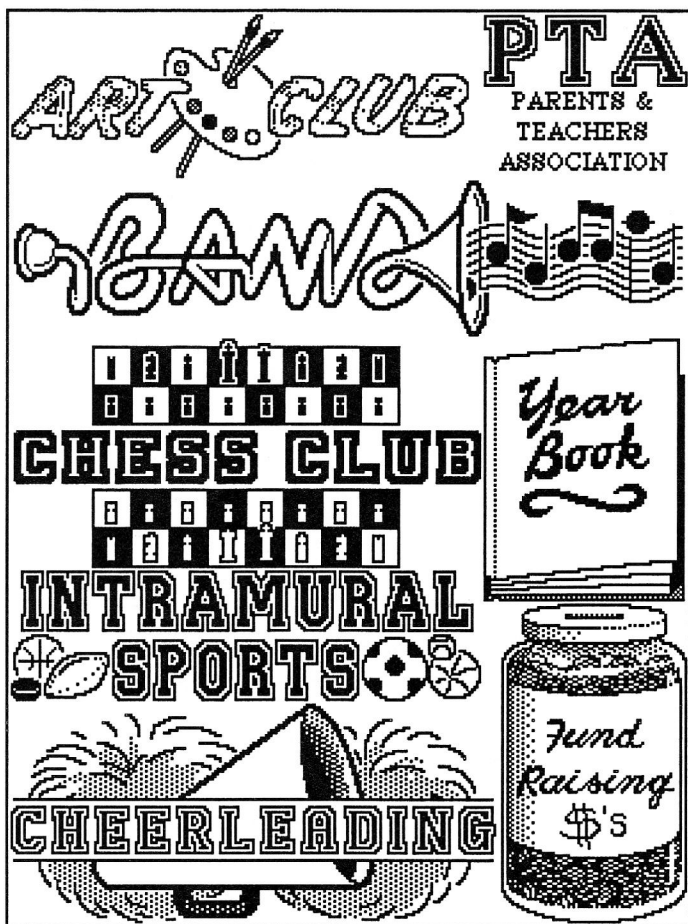

History1: Prehistoric Man and Sumerian Culture

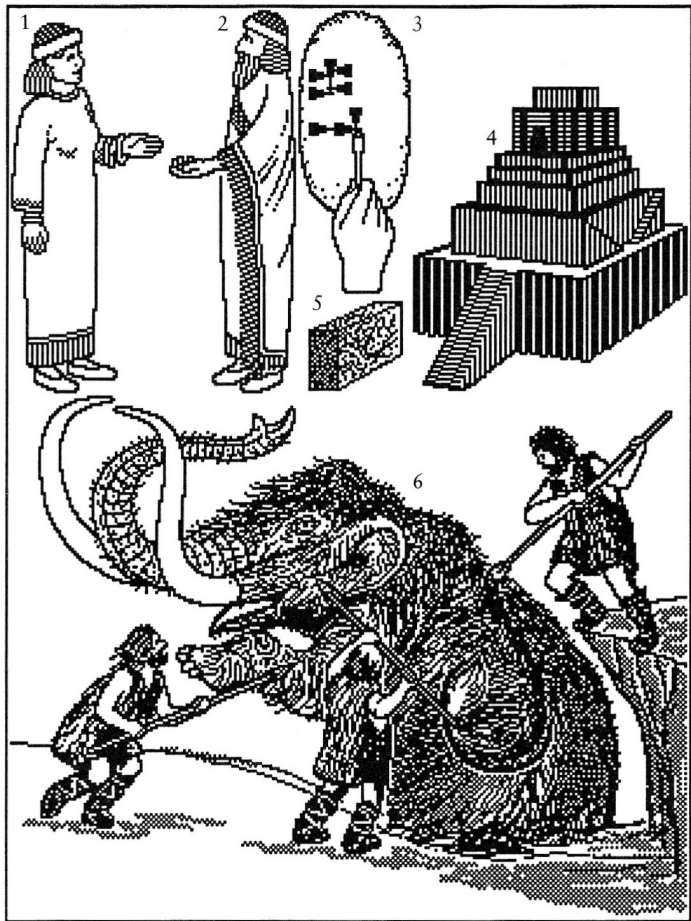

1. Sumerian woman
2. Sumerian man
3. Clay tablet with stylus & cuneiform writing

4. Ziggurat (Sumerian temple)
5. Sumerian mud brick
6. Woolly mammoth & Stone Age hunters

History2: Egyptian and Greek Culture

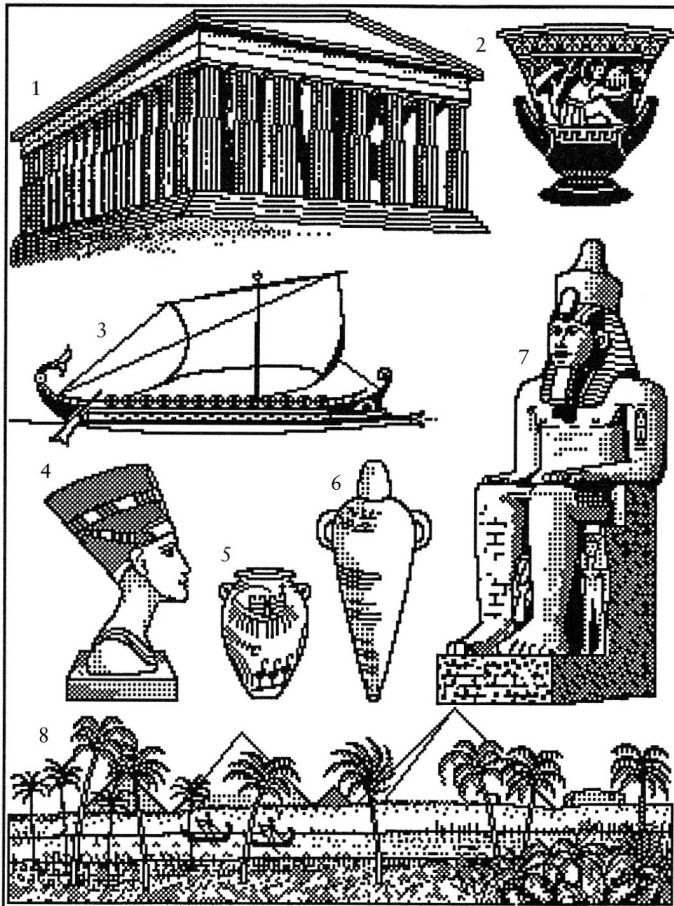

1. The Parthenon
2. Greek krater (wine-mixing bowl)
3. Greek galley
4. Queen Nefertiti

5. Decorative clay jar (Egyptian)
6. Storage vessel (Egyptian)
7. Ramses II
8. Nile River panorama

History3: Roman Empire and Medieval Europe

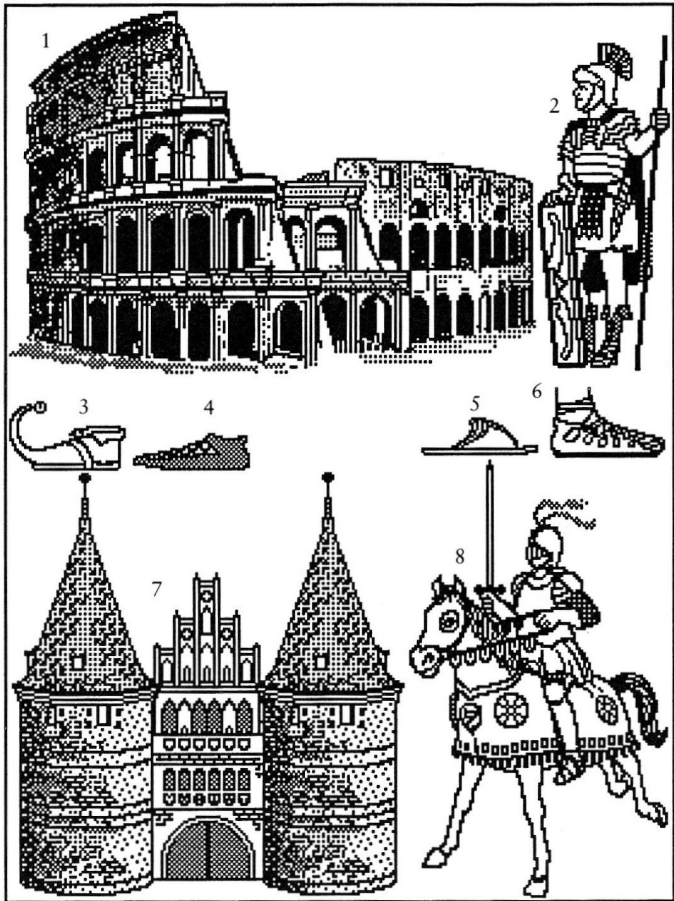

1. The Roman Colosseum
2. Roman soldier
3. Roman sandal
4. Roman sandal

5. Medieval shoe
6. Medieval shoe
7. Medieval fortified city gate
8. Armored knight (14th century)

See Addendum correction

History4: Renaissance and American Revolution

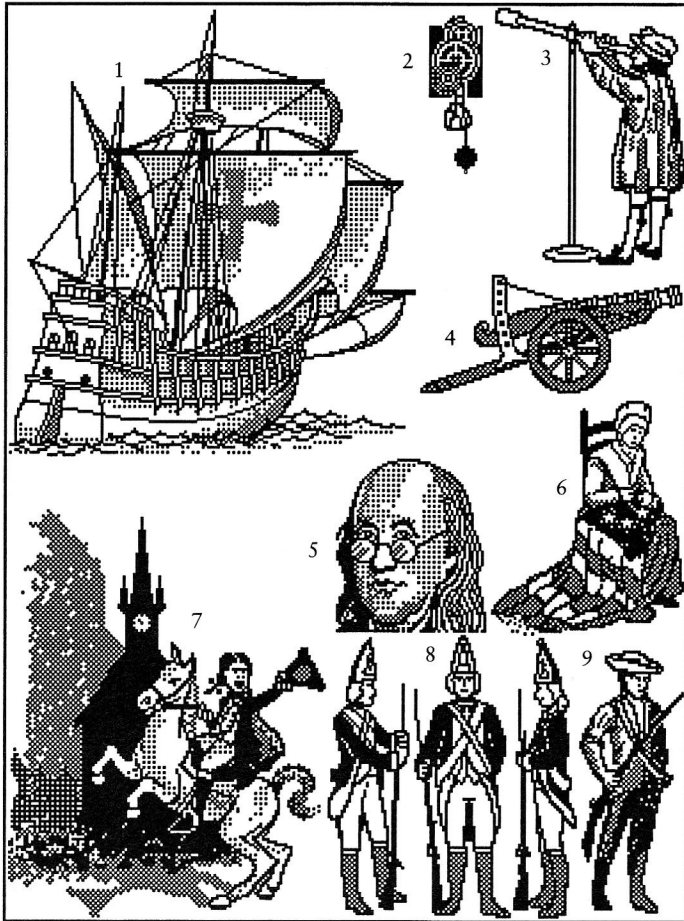

1. Santa Maria (Columbus' flagship)
2. 14th-century clock
3. Galileo and telescope
4. Early cannon
5. Benjamin Franklin

6. Betsy Ross
7. Paul Revere's midnight ride
8. British soldiers
9. American Minuteman

History5: Civil War through Roaring '20s

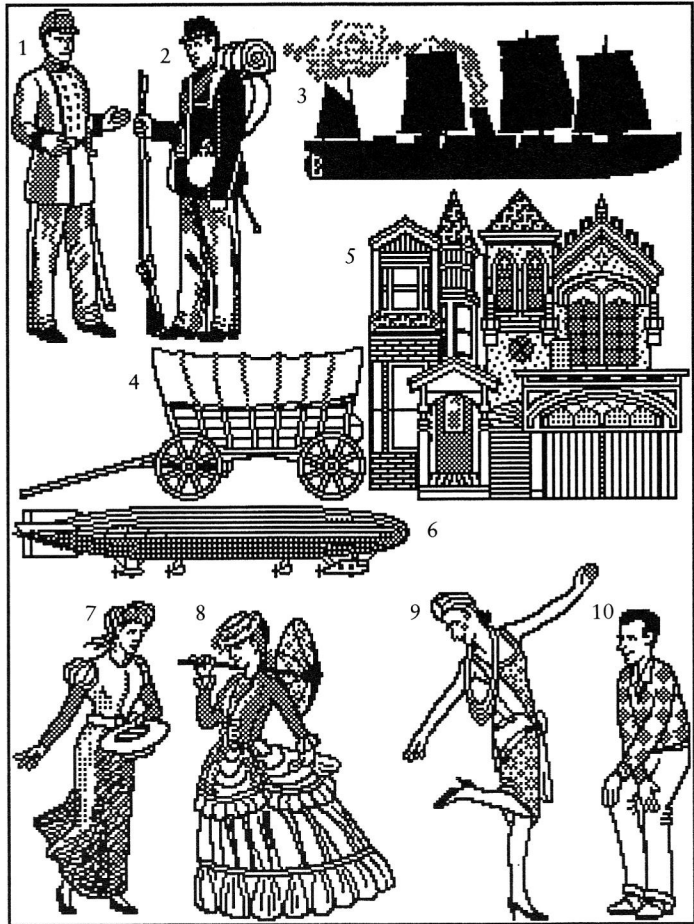

1. Confederate soldier
2. Union soldier
3. Transatlantic steamer, late 1800s
4. Conestoga wagon
5. Victorian row house, late 1800s

6. German Zeppelin (1918)
7. Victorian lady
8. Victorian lady
9. "Flapper" (Roaring '20s)
10. Young man (Roaring '20s)

History6: Native Americans, North and South America

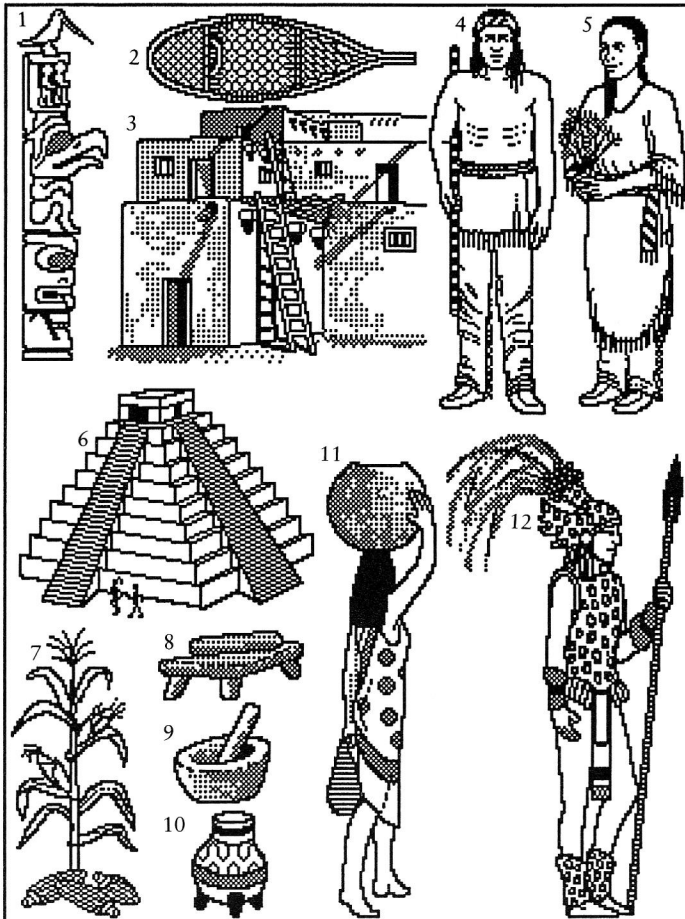

1. Totem pole
2. Snowshoe
3. Pueblo (Southwestern U.S.)
4. Apache man
5. Apache woman
6. Mayan pyramid

7. Maize plant (corn)
8. Corn grinder
9. Pepper and bean grinder
10. Clay vessel (Andes mountains)
11. Aztec woman
12. Aztec man

Insects 1

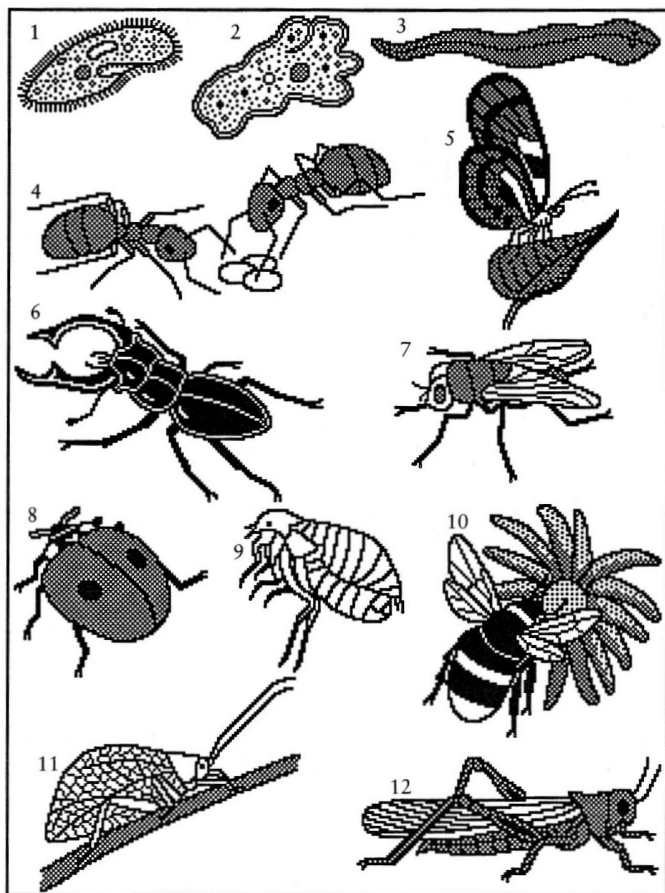

1. Paramecium
2. Amoeba
3. Flatworm
4. Worker ants

5. Butterfly
6. Stag beetle
7. Housefly
8. Ladybug (ladybird)

9. Flea
10. Bumblebee
11. Katydid
12. Locust

Inventions1

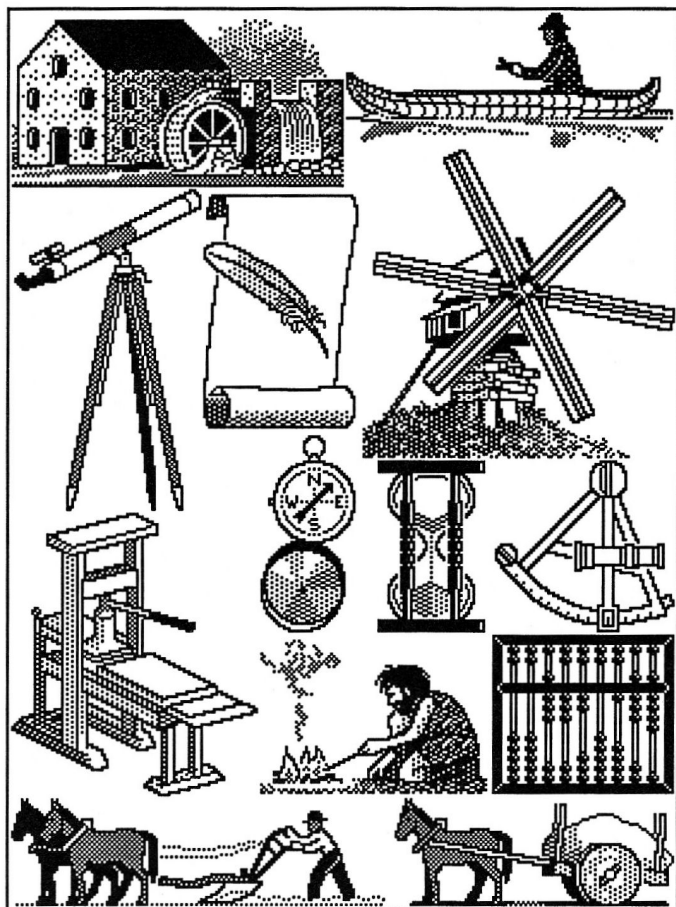

Inventions2



Literature1

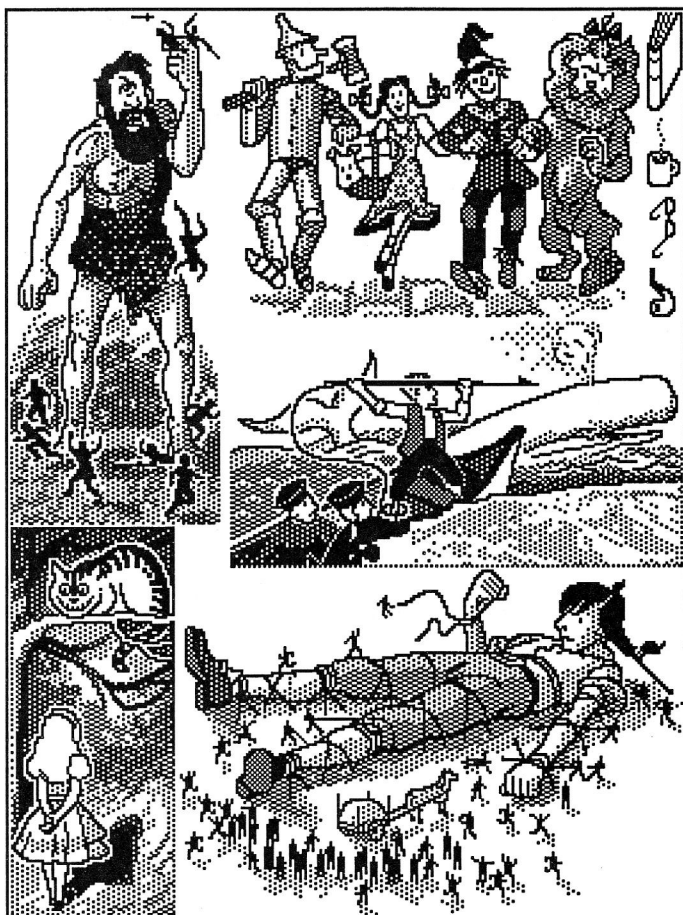

Mammals1

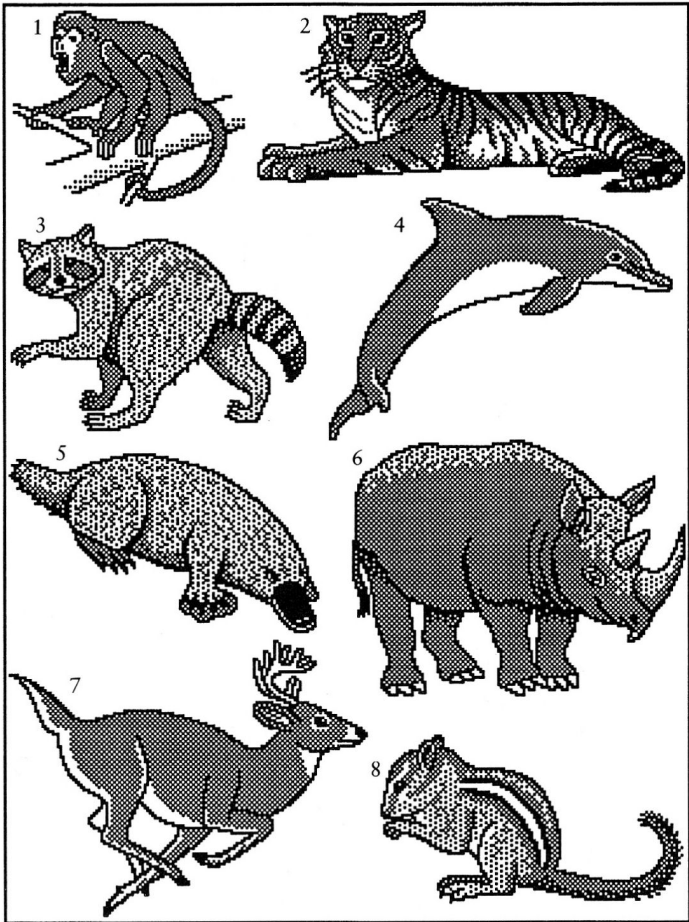

1. Howler monkey
2. Tiger
3. Raccoon
4. Bottle-nosed dolphin

5. Platypus
6. Rhinoceros
7. White-tailed deer
8. Chipmunk

Maps1: The World

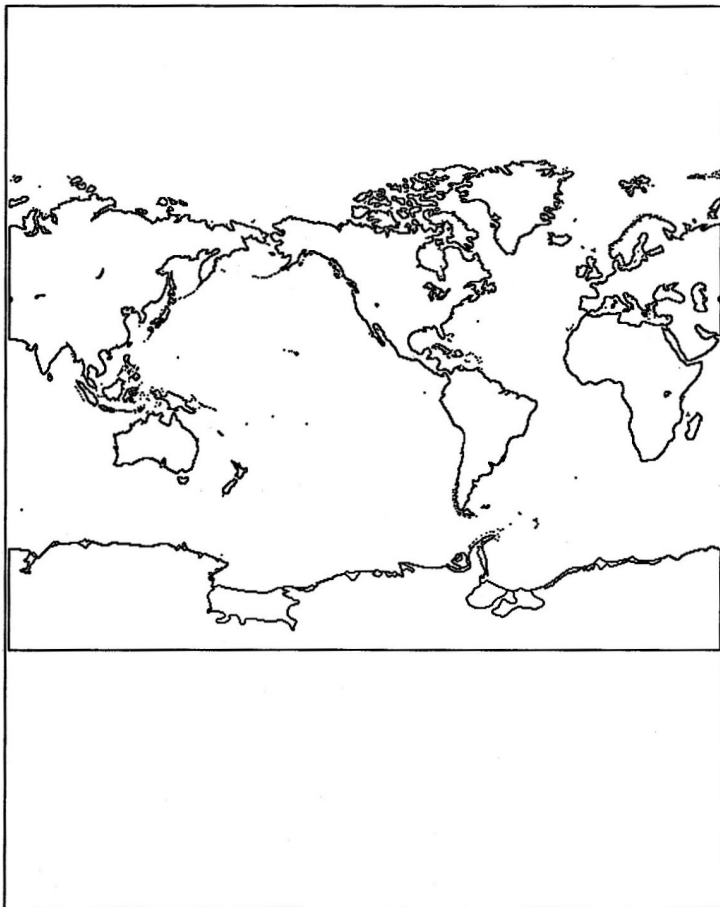

(50% reduction)

Maps2: United States



(50% reduction)

Maps3: South America



Maps4: Africa

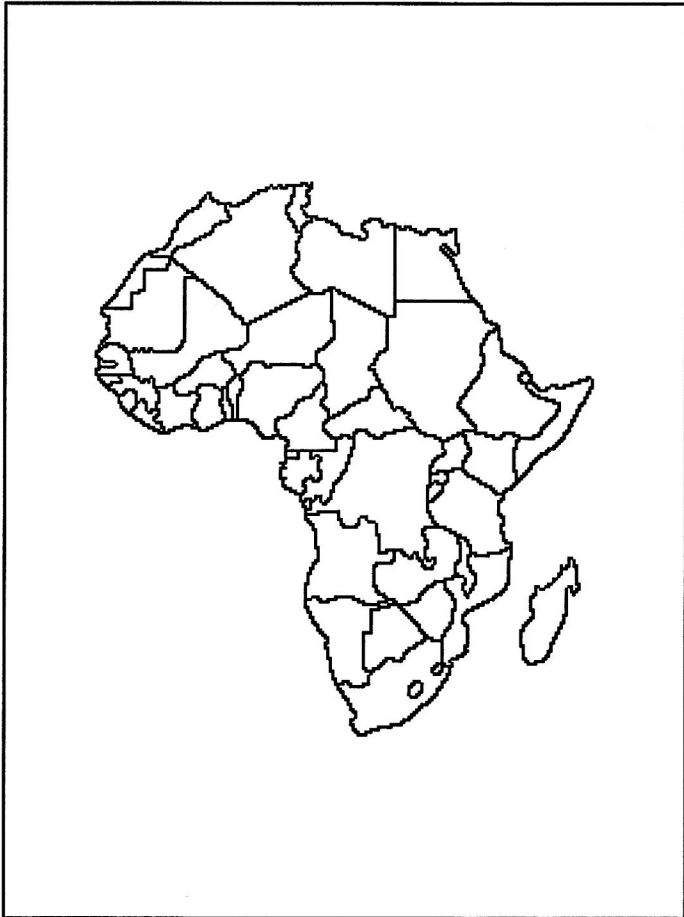

Maps5: Australia



Maps6: Europe



Maps7: Asia

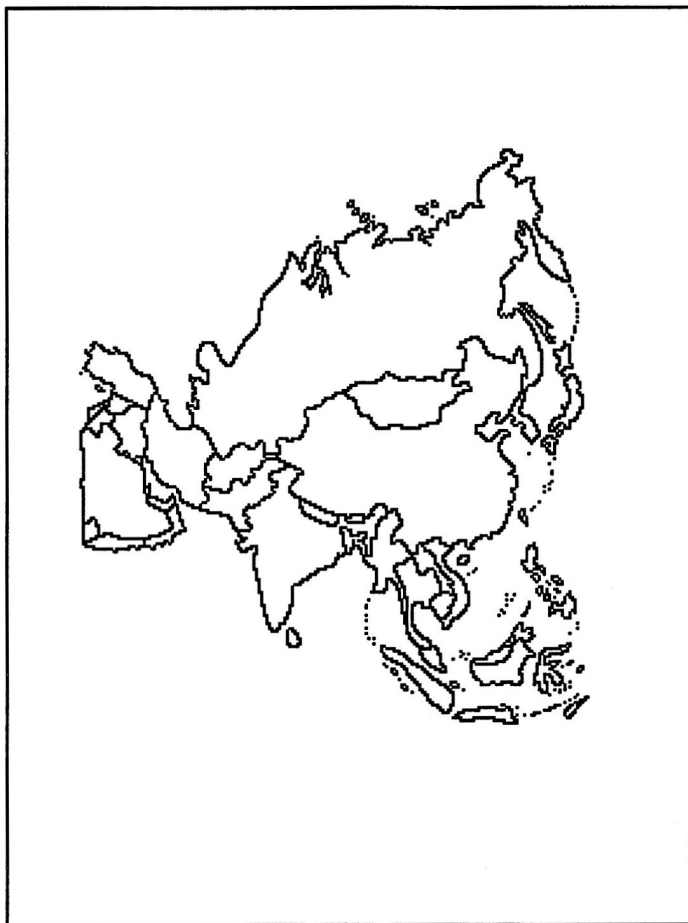

Maps8: North America



Meteorology1: The Water Cycle

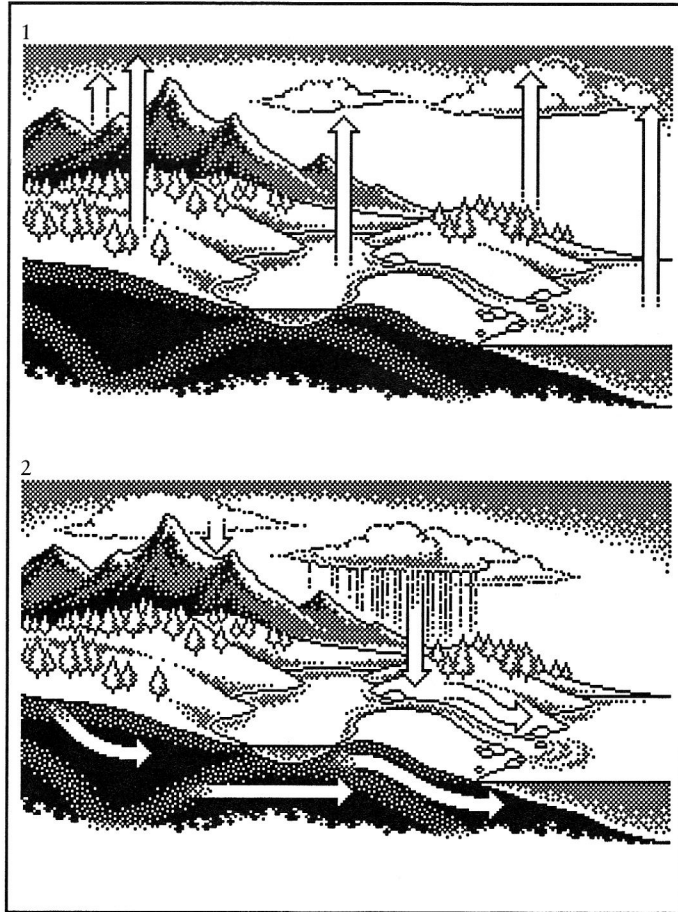

1. Moisture evaporates from oceans, land and vegetation, lakes and rivers, and snow and ice.
2. Rain, hail and snow fall to the earth, where the water runs off the land or soaks into the soil.

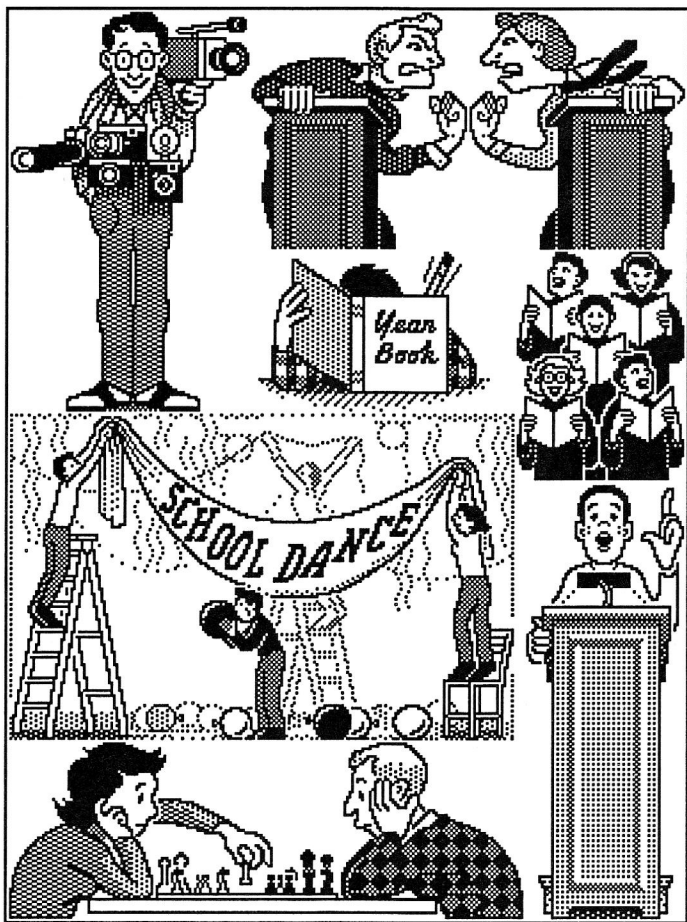

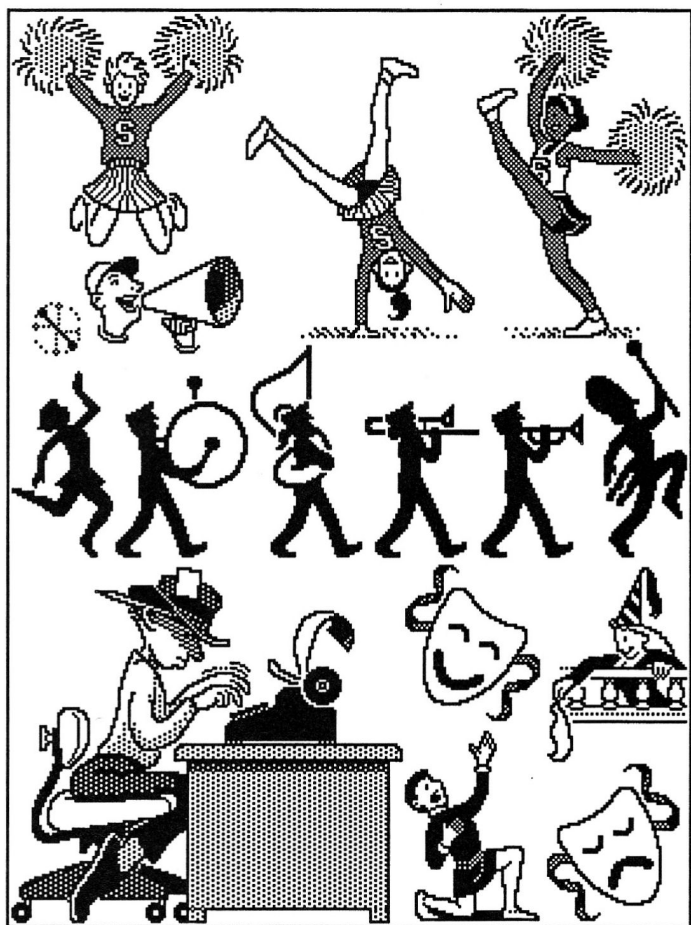

Mollusks1

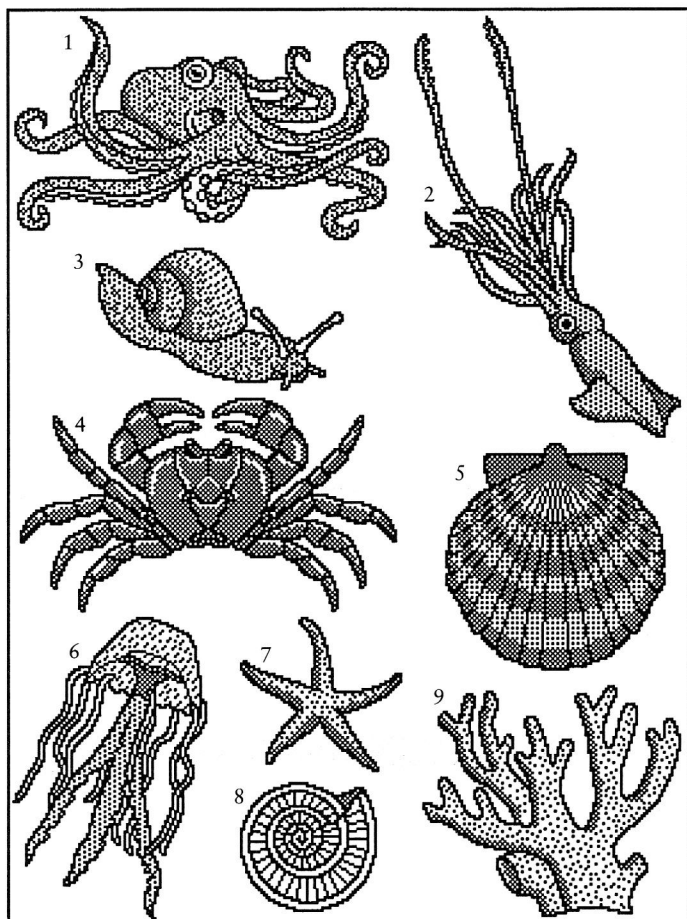

1. Octopus
2. Squid
3. Snail

4. Crab
5. Scallop
6. Jellyfish

7. Starfish
8. Nautilus
9. Coral

Money1: Currency



1. Dollar bill
2. 50-cent piece
3. 25-cent piece
4. 5-cent piece
5. 10-cent piece
6. Pine-tree shilling
(Massachusetts, 1652)
7. Spanish silver dollar (used in
colonies)
8. Shells
9. Penny
10. Beads
11. Owl of Athens (430 B.C.)
12. Roman coin (37 B.C.)
13. Yap Island coin

Music1

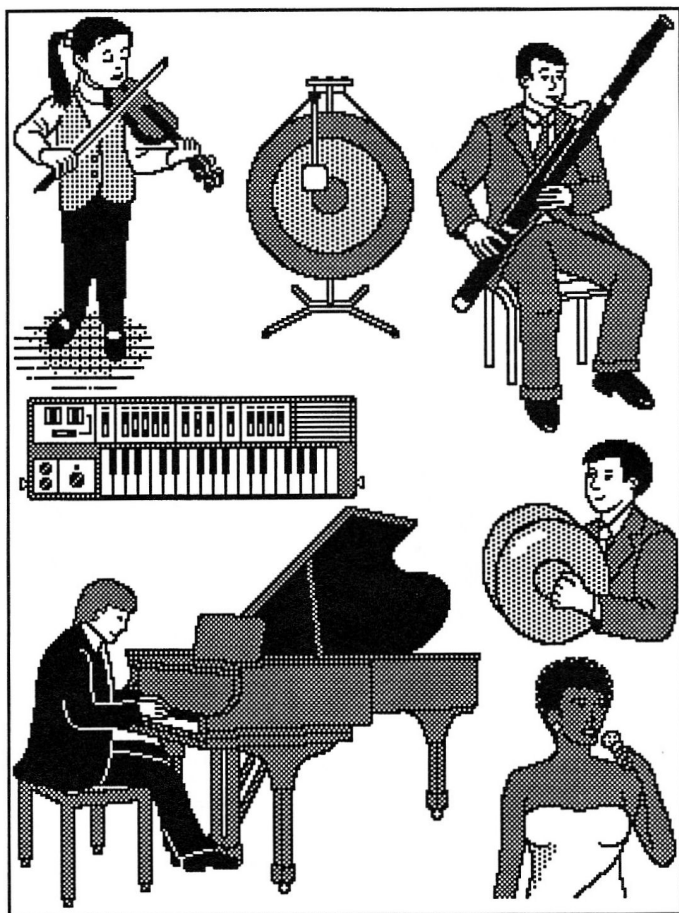

Music2: Musical Notation and Instruments

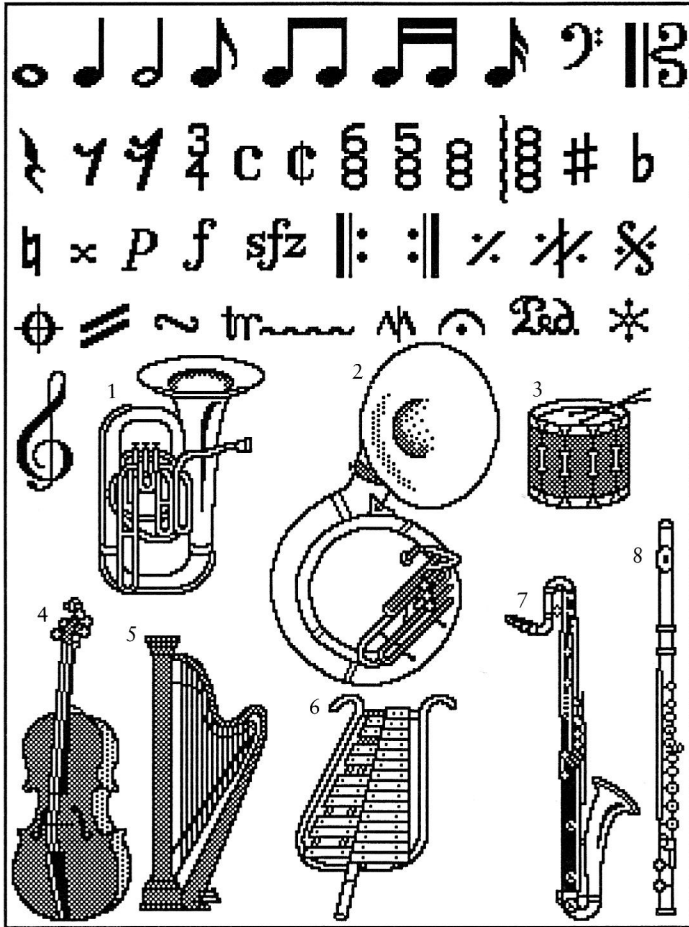

1. Sousaphone
2. Tuba
3. Drum

4. Cello
5. Concert harp
6. Glockenspiel

7. Contrabass clarinet
8. Flute

See Addendum correction

Music2: Musical Notation in detail

See Addendum correction

- | | | | |
|--------------------|-------------------------------|-------------------------------|--------------------------|
| 1. Whole note | 12. Sixteenth rest | 22. Natural | 32. Return to Segno |
| 2. Quarter note | 13. 3/4 (waltz) time | 23. Double sharp | 33. Tremolo |
| 3. Half note | 14. Common (4/4) time | 24. Piano (soft) | 34. Turn |
| 4. Eighth note | 15. 2/4 "Cut" time | 25. Forte (loud) | 35. Trill |
| 5. Eighth notes | 16. 6/8 "Jig" time | 26. Sforzando | 36. Mordent |
| 6. Sixteenth note | 17. 5/8 time | 27. Repeat from here | 37. Fermata |
| 7. Sixteenth notes | 18. Triad | 28. Repeat to here | 38. Depress damper pedal |
| 8. Bass (F) clef | 19. Arpeggio ("rolled" chord) | 29. Repeat last measure | 39. Release damper pedal |
| 9. Alto (C) clef | 20. Sharp | 30. Repeat last measure twice | 40. Treble (G) clef |
| 10. Quarter rest | 21. Flat | 31. Segno | |

Plants1

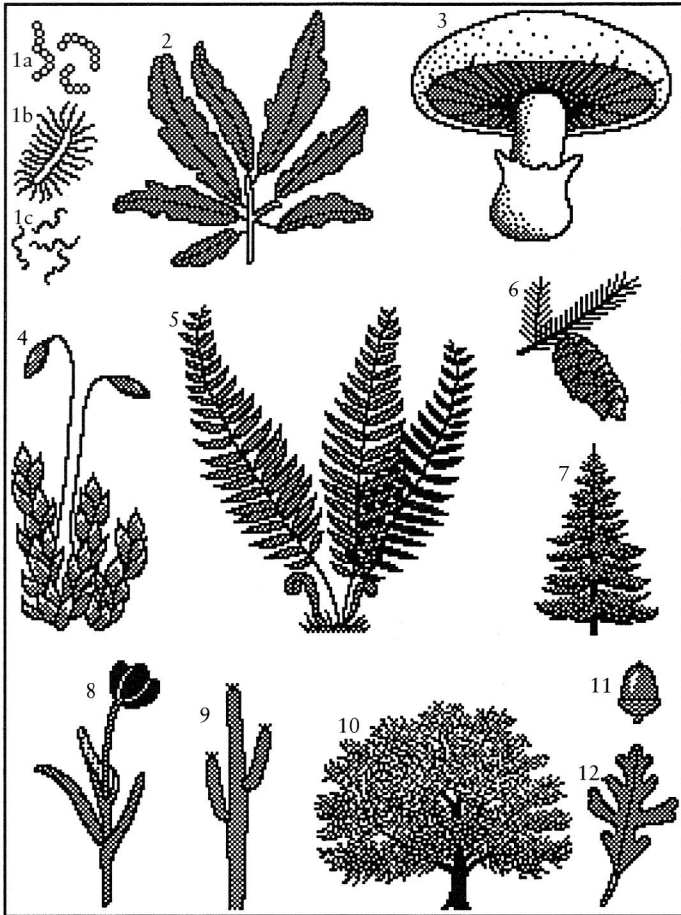

1. a. Cocci bacteria
- b. Bacilli bacteria
- c. Spirilla bacteria
2. Seaweed
3. Mushroom
4. Moss
5. Fern
6. Bigcone Douglas fir cone

7. Bigcone Douglas fir
8. Tulip
9. Giant saguaro
10. White oak
11. Acorn
12. White oak leaf

Preschool1



Reptiles1: Reptiles and Amphibians

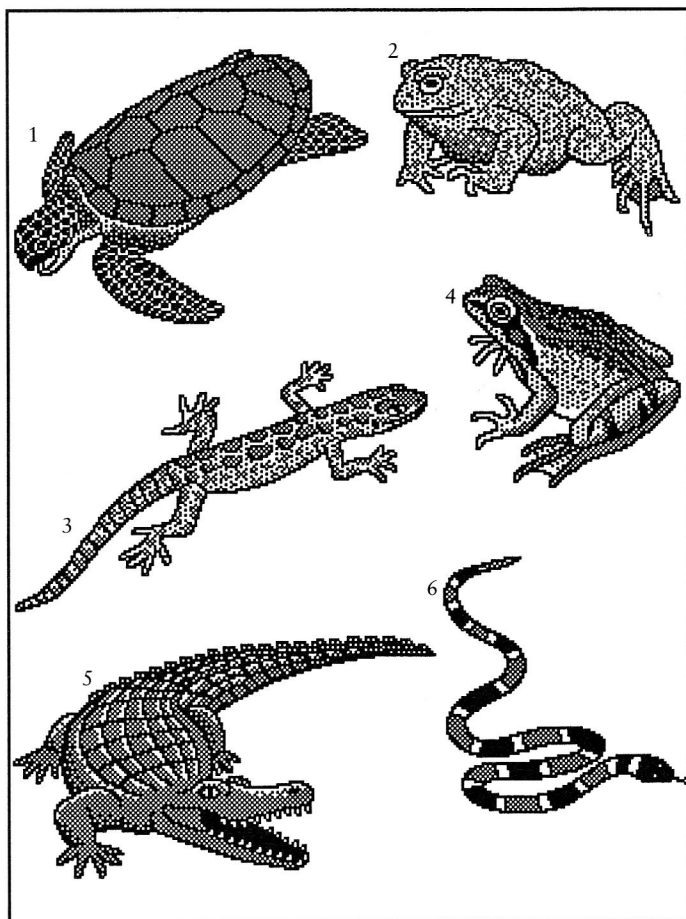

1. Green turtle
2. Toad

3. Granite night lizard
4. Frog

5. Alligator
6. Eastern coral snake

Shop1

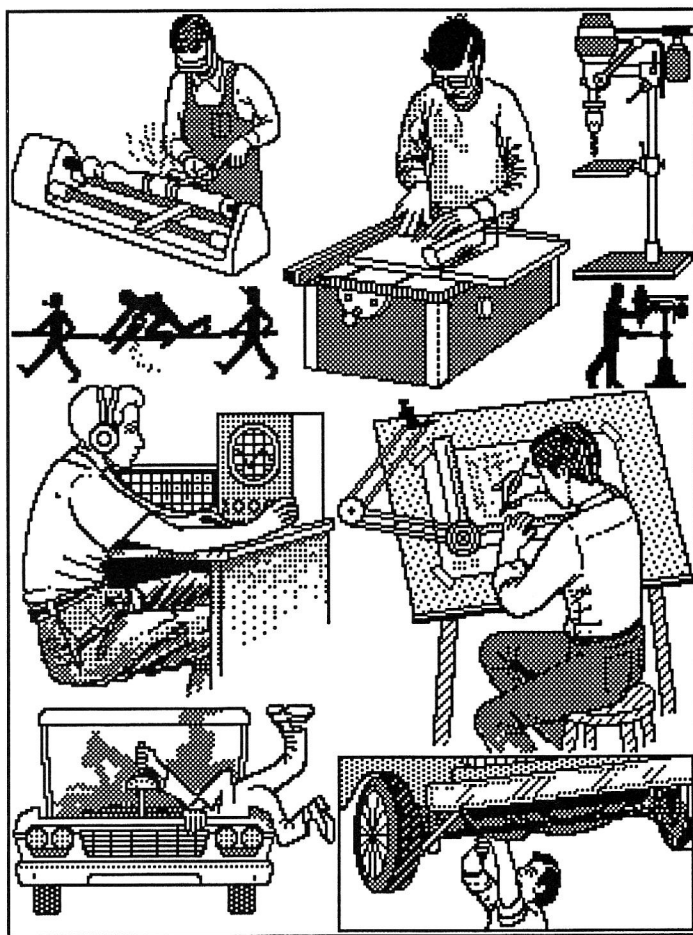

Supplies 1

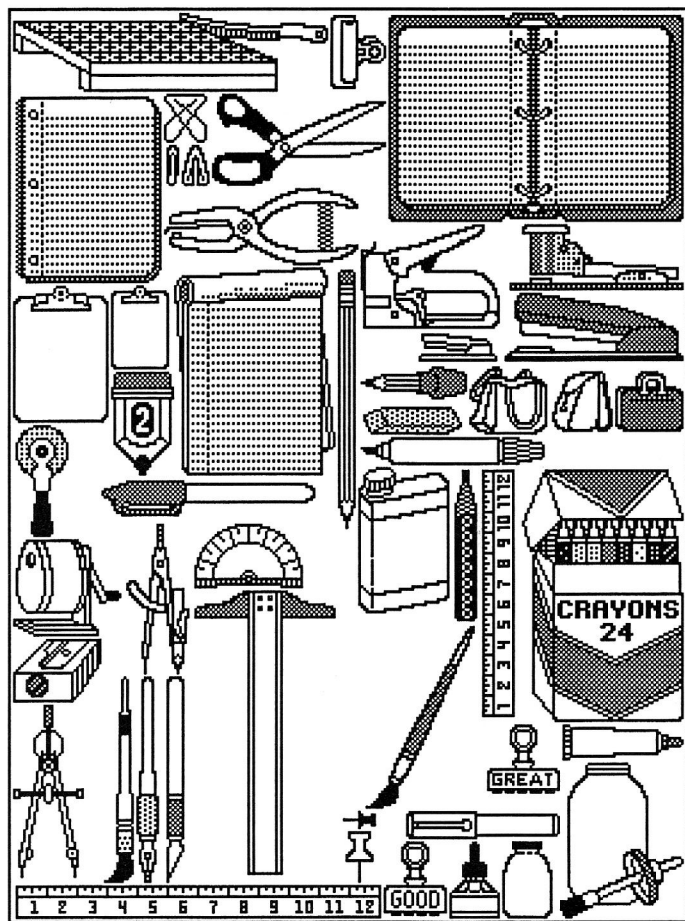

Supplies2

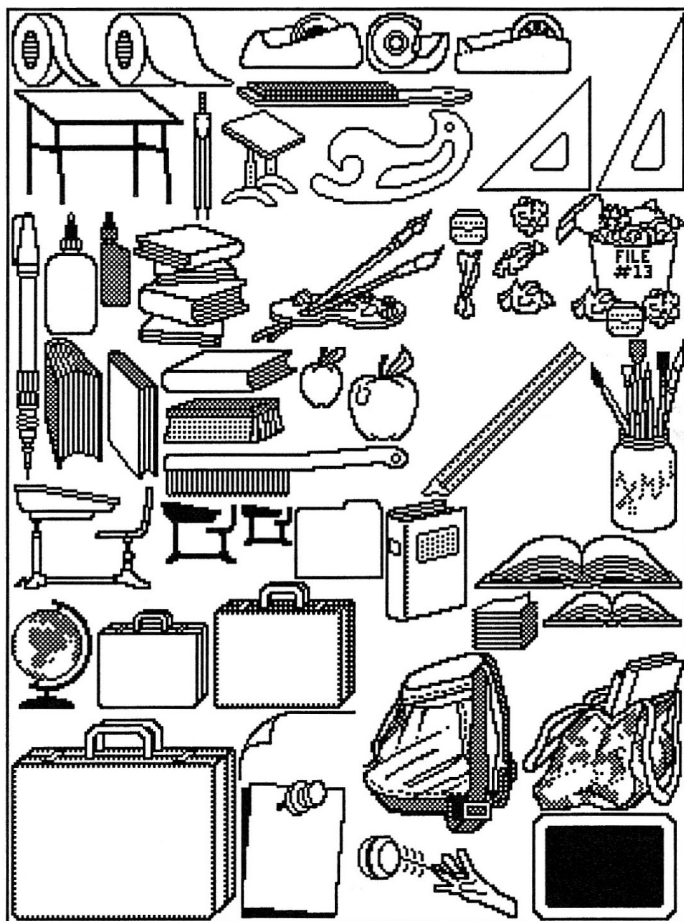

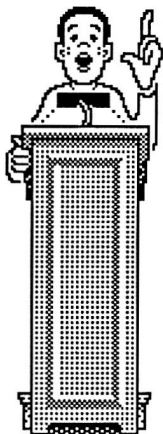

Tell us what you like

Please take a moment to fill out this questionnaire. Your responses and suggestions will help us in developing new *Works of Art* packages.

1. What is your overall reaction to the *Education Series Sampler*?

- Very satisfied Somewhat satisfied
 Somewhat dissatisfied
 Very dissatisfied

2. What do you like about the *Education Series Sampler*?

- | | | |
|------------|-------------------------------|----------------------------------|
| Quality | <input type="checkbox"/> Like | <input type="checkbox"/> Dislike |
| Quantity | <input type="checkbox"/> Like | <input type="checkbox"/> Dislike |
| Price | <input type="checkbox"/> Like | <input type="checkbox"/> Dislike |
| Usefulness | <input type="checkbox"/> Like | <input type="checkbox"/> Dislike |

3. What *categories* of artwork in this package do you like the most? Please specify.

4. What *categories* of artwork would you like to see in future *Works of Art* packages? (Check off all categories you are interested in.)

- Assortments Specific holidays School activities
 Religious art Sports Maps Animals People
 Business-related art (logos, trademarks, people, etc.)
 Art to help make forms, charts or line drawings
 Artwork made specially for output on laser printers
 Artwork made specially for output on color printers
 Specific curriculum topics (please specify) _____

Other (please specify) _____

Continued

(cut along the dotted line)

5. What *individual pieces* of art would you like to see? Please specify.

6. Check one box.

- I like a greater percentage of realistic art.
- I like a greater percentage of cartoon-like art.
- I like an even mix of realistic and cartoon-like art.

7. Check one box.

- I like more artwork of people.
- I like more artwork of objects.
- I like an even mix of people and objects.

8. Check one box.

- I like more small art (1 square inch or less).
- I like fewer overall pieces, but more medium-size art (1-2 square inches).
- I like fewer overall pieces, but more large art (bigger than 2 square inches).
- I like the same mix of sizes as in this package.

9. Check one box.

- I like partially-completed artwork that I can modify.
- I like completed artwork that I don't have to modify.

10. Other comments: _____

Thank you for your feedback. Please cut this questionnaire along the dotted line and mail to:

Springboard Software, Inc.
Attn: Works of Art Feedback
7808 Creekridge Circle
Minneapolis, MN 55435

Limited Warranty

Springboard Software, Inc., warrants this software product against defects in manufacturing for a period of thirty days following purchase. If during that period, you cannot properly load the program, you may return it with your dated sales receipt to Springboard for a replacement. After thirty days a replacement can be obtained by sending the original product and \$5.00 to the manufacturer, provided that the software is then being manufactured by the manufacturer.

Returns should be sent to: Springboard Software, Inc., 7808 Creekridge Circle, Minneapolis, MN 55435.

THIS LIMITED WARRANTY IS IN LIEU OF ALL OTHER WARRANTIES. ANY IMPLIED WARRANTIES, INCLUDING ANY WARRANTIES OF MERCHANTABILITY OR FITNESS FOR A PARTICULAR PURPOSE, WHICH ARE NOT SO EXCLUDED ARE LIMITED IN DURATION TO THE DURATION OF THIS LIMITED WARRANTY.

THE MANUFACTURER IS NOT RESPONSIBLE FOR ANY INCIDENTAL OR CONSEQUENTIAL DAMAGES CAUSED BY THE USE OF THIS SOFTWARE PRODUCT, AND IN ANY CASE THE MANUFACTURER'S LIABILITY FOR ANY CLAIM REGARDING THIS SOFTWARE PRODUCT IS LIMITED TO ITS PURCHASE PRICE.

Some states do not allow limitations on how long an implied warranty lasts, so the above limitation may not apply to you. Some states do not allow exclusion or limitation of incidental or consequential damages, so the above exclusion may not apply to you. This warranty gives you specific rights, and you may also have other rights which vary from state to state.

WORKS OF ART™

Addendum

This addendum contains corrections to the Works of Art™ Education Series Sampler manual. Please note these corrections in your booklet.

Page 13: Teeth

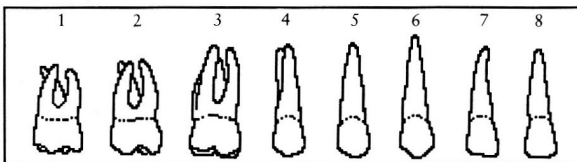

1. Wisdom tooth
2. Molar
3. Molar
4. Bicuspid

5. Premolar
6. Canine
7. Lateral incisor
8. Middle incisor

Page 24: History3

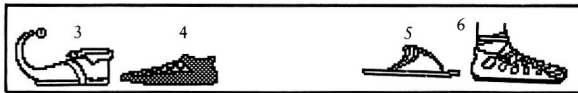

3. Medieval shoe
4. Medieval shoe

5. Roman sandal
6. Roman sandal

Page 47: Music2

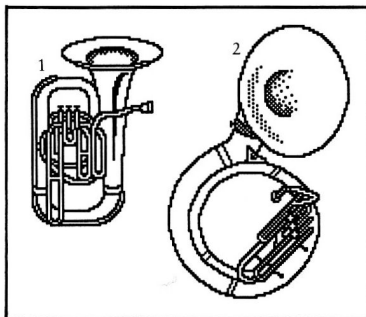

1. Tuba
2. Sousaphone

Page 48: Music2



6. Sixteenth notes
7. Sixteenth note

Springboard Software, Inc.
7808 Creekridge Circle
Minneapolis, MN 55435
612-944-3912