

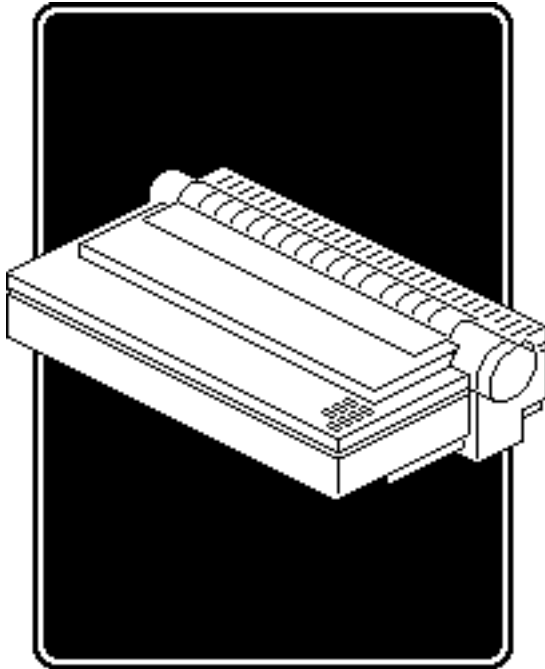

ImageWriter II/L





Introduction

The electrical operation of the printer consists of five printed circuit boards, three motors, and several switches.

The boards are the power supply board, main board, sub PCB board, print head board, and the operation panel board.



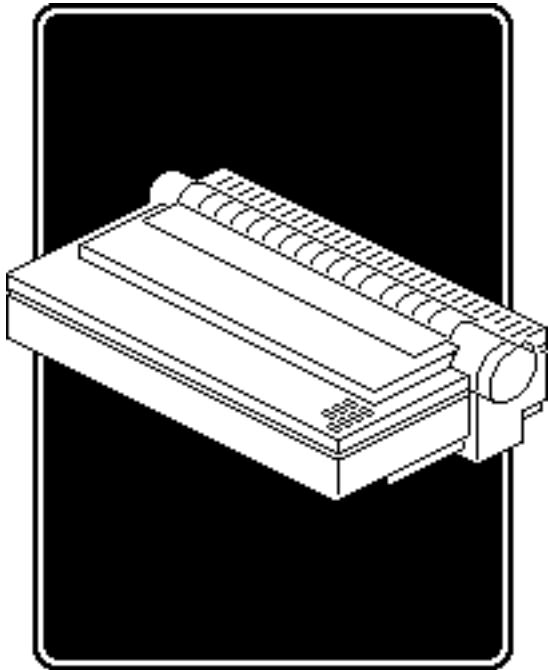

The three motors are the carrier motor, line feed motor, and the ribbon position motor.

Switches are the home position switch, paper-out sensor switch, and the ribbon switch.



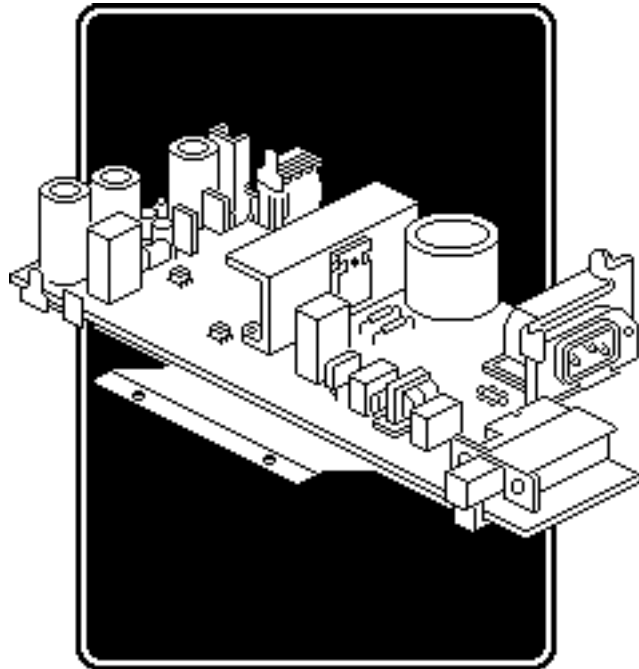

Power Supply

The ImageWriter II/L has a switching type power supply that eliminates the need for a bulky transformer. When the input AC current is applied to this board, the power supply reduces and rectifies the voltage to the following DC voltages:

- + 5 V DC
- - 5 V DC
- + 26 V DC



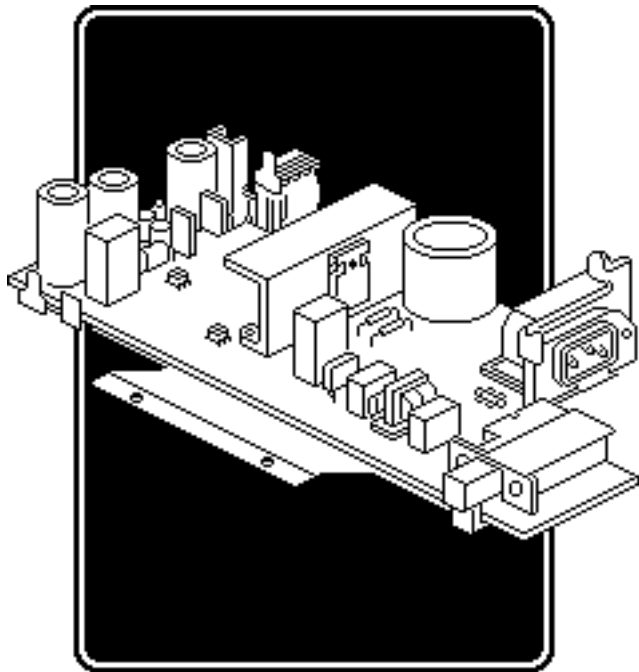

The + 5 and -5 V DC voltages are for logic; the + 26 V DC is for motor drive. All the voltages are fed from connector CN5 on the power supply board to connector CN3 on the main board. From the main board the voltages are distributed to the other boards and motors.





The power supply has two fuses to help protect the electronics—FU1 is a 120 V 2-amp fuse and FU2 is a 125 V 4-amp fuse.

Note: Although not on the power supply board, there is another fuse, FU1, located on the main board that protects the + 26 motor voltage.

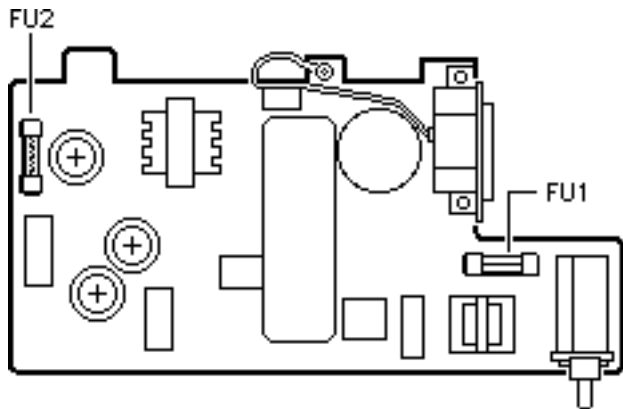

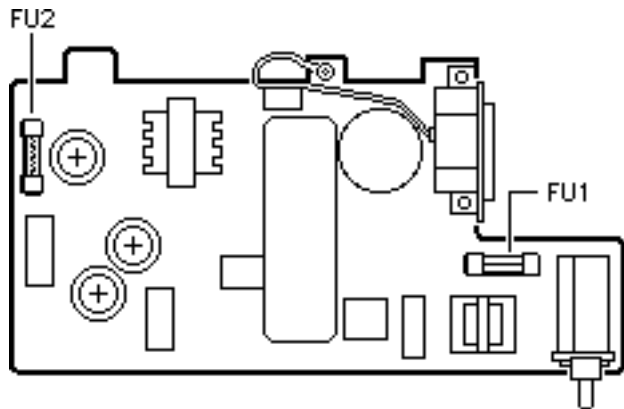

The on/off power switch is connected to the power supply board and disconnects or connects the main AC current to the board. The switch is comprised of a cable type plunger that is attached to the power supply board.

Caution: This power supply is not compatible with the older ImageWriter II. Do not attempt to switch the power supplies between models.





Main Board

The main board is the heart of the printer. Besides handling the distribution of the voltages, it also handles all the logic that controls the printer. It is also the source of the drive signals for the print head. All sensor signals that affect the operation of the printer are fed to this board.

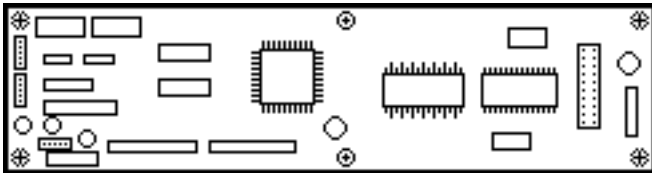

ROM

The ROM (IC10) chip has the start-up routines and several features such as character sets and self-test routines built in.

RAM

The RAM (IC9) is used in the transfer of data and acts as a buffer. When printing starts, the data to be printed is transferred from the host CPU to the RAM on the printer. From the RAM the data is passed through the logic and sent to the print head to print. Turning off the printer clears the RAM.

Interface Circuits

The interface circuits (IC2 and IC3) on the main board handle the data transferred from the host CPU via the sub PCB board. These circuits also handle the status and control lines from the printer to the host CPU.

Print Head Drivers

The print head drivers (IC5 and IC6) process the print head drive signals from the CPU and gate array. The signals are sent to the print head board through CN5.



CPU and Gate Array

The CPU (IC8) along with the gate array (IC4), handles the logic and decision-making of the printer. They combine to evaluate the status of the printer and issue commands concerning when to transfer data, when to start printing, when to run the motors, and what actually prints. All the functions of the printer are controlled by these two devices. The rest of the circuits are supporting circuits.

Carrier Motor Drivers

The carrier motor circuit is made up of transistors Q1, Q2, Q12, Q13 and IC1. The transistors make up a circuit that is used as common returns from the motor. The transistors also supply the higher voltage and current needed to drive the motor. IC1 is a transistor pack that completes the drive signals circuit when turned on. Each of the four signals drives a phase of the motor. These drive signals go to the carrier motor on the printer through CN2.



Line Feed

The drive circuit is made up of transistors Q8, Q9, Q10, and Q11. Four drive signals from the gate array are processed in this circuit. Higher voltage and current are added to the phase control signals to turn on the line feed motor. The signals are sent to the line feed motor and the ribbon motor through CN1.

Ribbon Motor Drivers

This circuit is made up of transistors Q3, Q4, Q5, Q6 and Q7. When turned on, the line feed motor signals from the gate array are supplied with more current in the drive circuit and sent out to the motor. The common return line is on Q7, which is turned on for each phase signal sent to the motor. These signals are sent through CN5.



Reset Circuit

This circuit is used when the printer is turned on to keep the logic in a reset state until the voltages are up to correct values. Once the voltages are at the correct level, reset is released and the logic is allowed to start functioning from a known state.

Connector CN6

This connector is a LocalTalk option card connector. This card allows the printer to communicate on the LocalTalk network so that multiple users can use the printer.

Clock Crystals

There are two clock crystals on the main board. The clock X1 for the gate array IC4 runs at 17.2 MHz. The clock X2 for the CPU runs at 12 MHz.

DIP Switches

The configuration DIP switches are mounted on the main board and can be changed to make the printer perform in different modes, or control printer protocols. The switch settings affect both the CPU and the gate array logic.



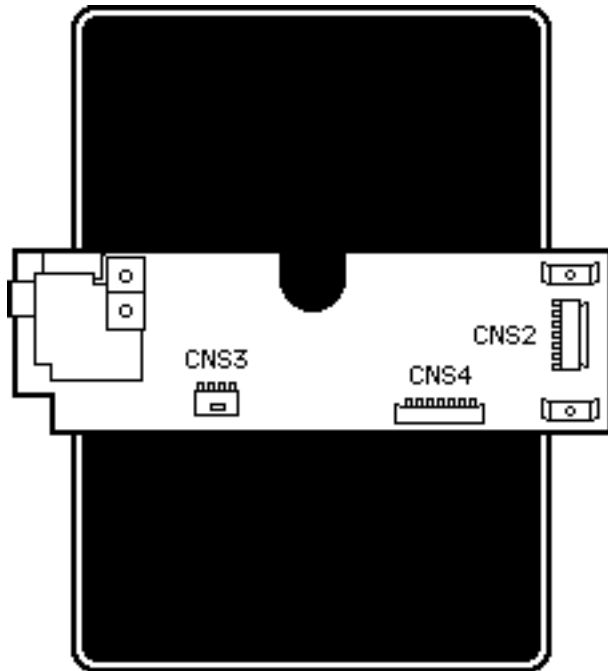

Sub PCB Board

The sub PCB board acts as an interface board. The interface cable from the host CPU is plugged into the connector CNS1 on this board. The signals from the host CPU pass through the sub PCB board on their way to the main board. If a cut-sheet feeder is attached to the printer, the signals pass through the sub PCB board through CNS2, which controls the actions of the feeder.



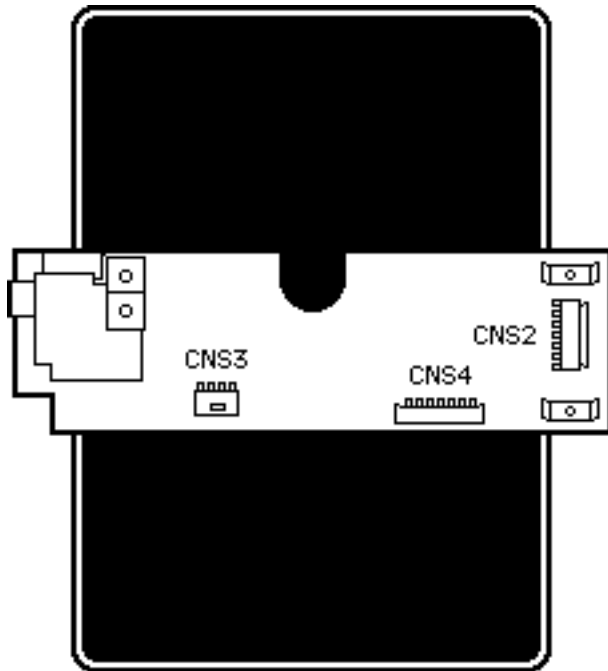

The paper-out sensor wires go to this board through CNS3 and are passed along to the main board.

All the signals coming or going to the sub PCB board are sent through CNS4 and the ribbon cable to the main board at connector CN4.



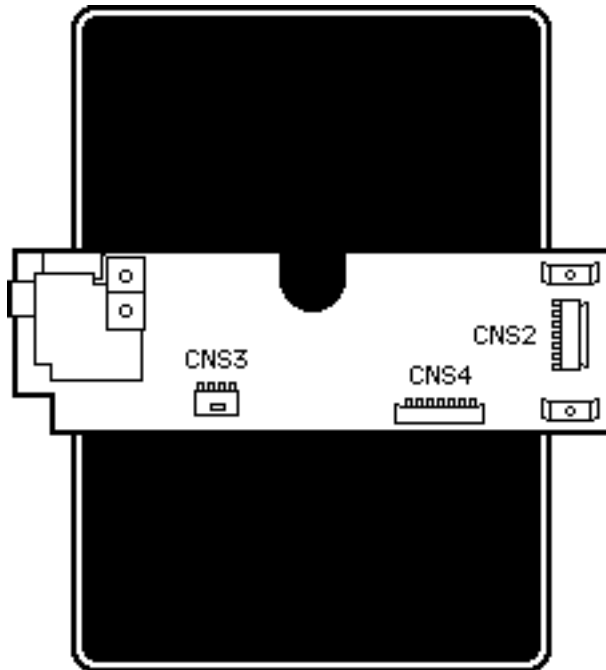

Print Head Board

The print head board receives the print head drive signals from the main board through CNH1. The signals are then sent out on connector CNH2 to the print head. This board also handles the ribbon motor drive signals and the ribbon switch signals. If the switch is activated, a color ribbon is detected.



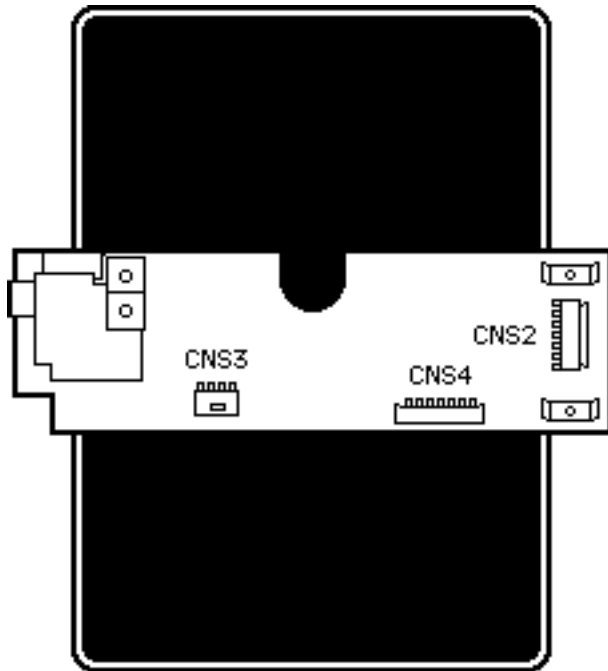

This information is sent to the main board, which in turn sends controlling signals to the ribbon motor to control the position of the ribbon to allow color printing.

The home position switch alerts the CPU that the carriage is at the far left side of the printer, which is home position.





Operation Panel Board

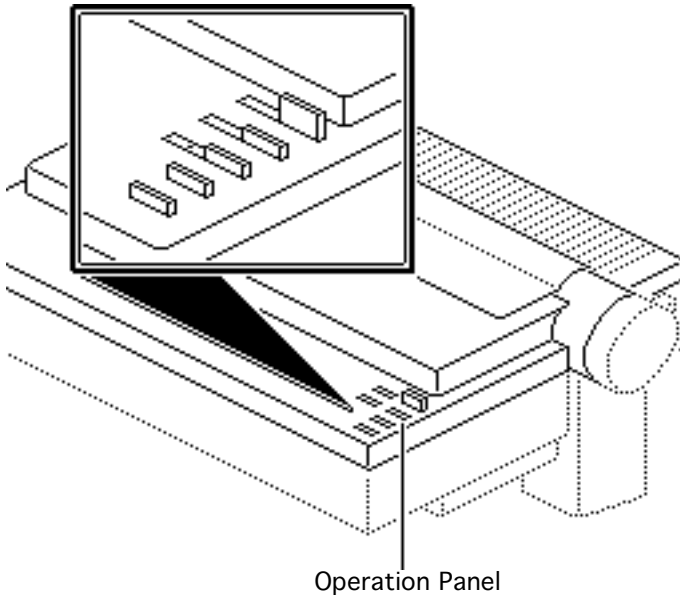

The operation panel board has the switches (select, print quality, line feed, and form feed) and indicators (error, power, print quality, and select) mounted on it. It interfaces with the CPU through CN7 on the main board. While the power switch button is located on the operation panel, it is not connected to the operation panel board.



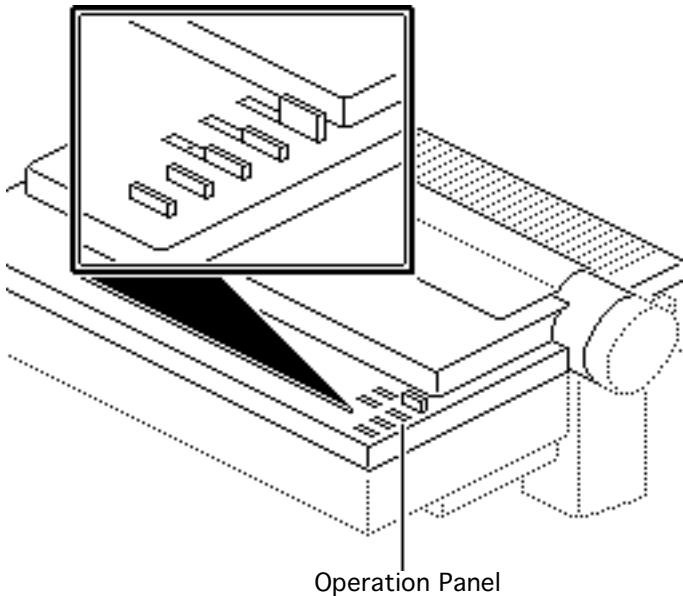

The switch button just passes through to the switch mounted on the main frame underneath the operation panel.





Operation Panel

The operation panel consists of operating switches and indicator lights.

The operating switches are the buttons with which you control the printer, and the indicator lights let you know what state the printer is in.

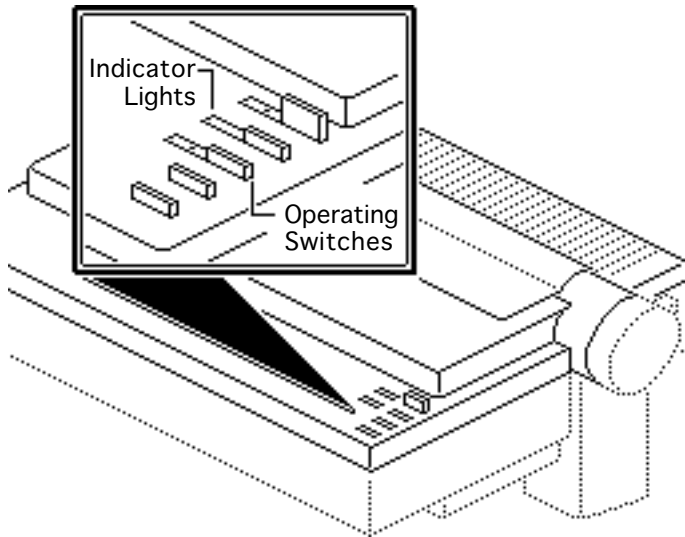



Operating Switches

Power Switch - The power switch turns the printer on and off.

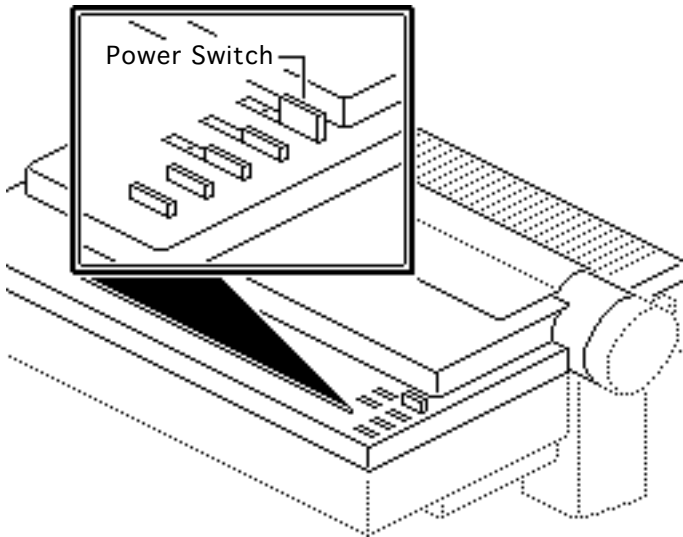

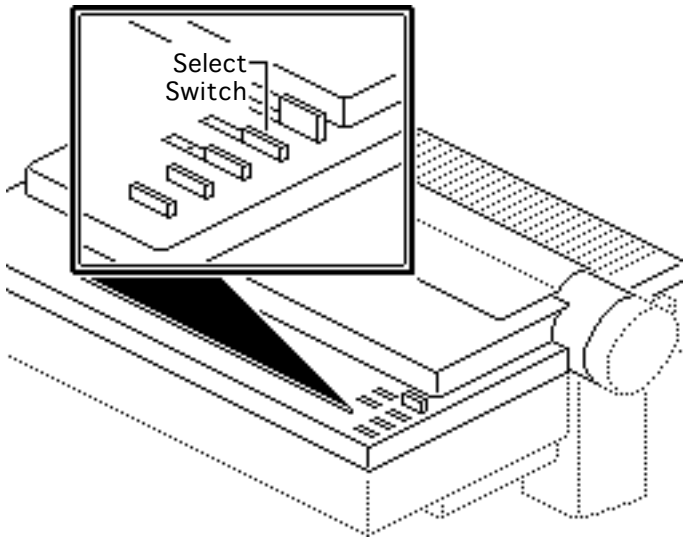

Select Switch - The select switch toggles the printer between a selected (online) and a deselected (off-line) state. If printing is in progress when the select switch is pressed, the printer finishes printing the current line and a maximum of two additional lines, and stops printing.



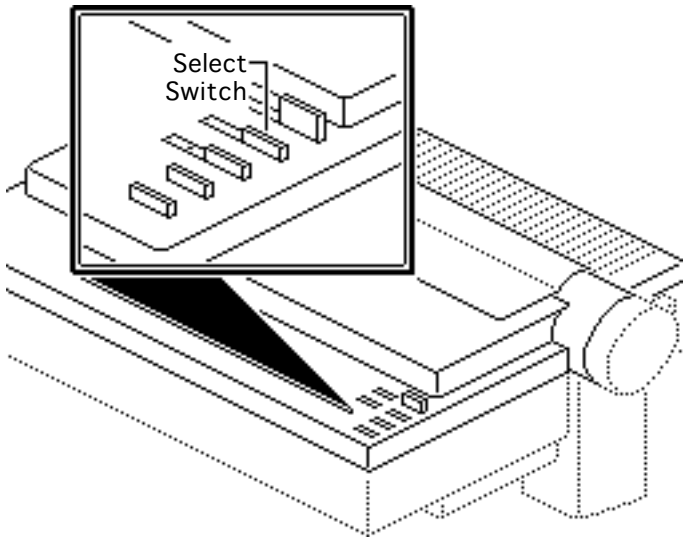

If you want to clear the buffer, you must turn off the printer. Pressing the select switch also clears a corrected error condition. If an out-of-paper condition exists, pressing the select switch temporarily overrides the error to allow the print of one line. This process is repeatable as long as there is printable data in the printer buffer.



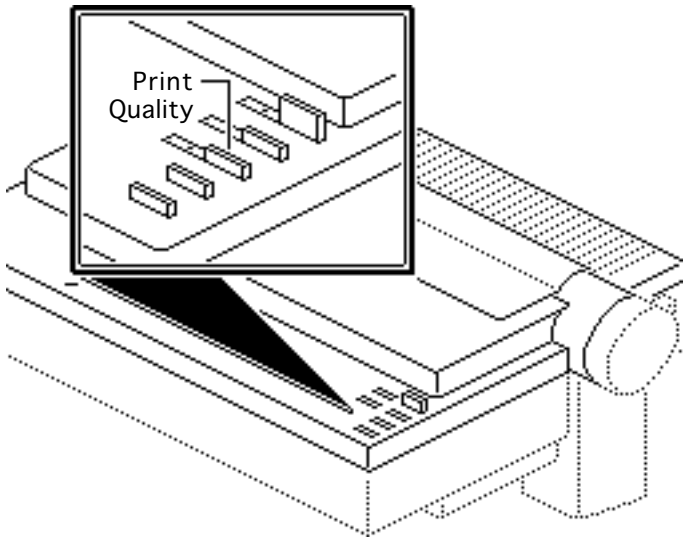

Print Quality Switch - The print quality switch allows the user to choose one of three printing modes. Pressing the print quality switch repeatedly changes the mode from the standard print mode, to the NLQ print mode, to the draft print mode, back to the standard print mode again. The print quality switch does not function unless the printer is in an off-line (deselected) state.



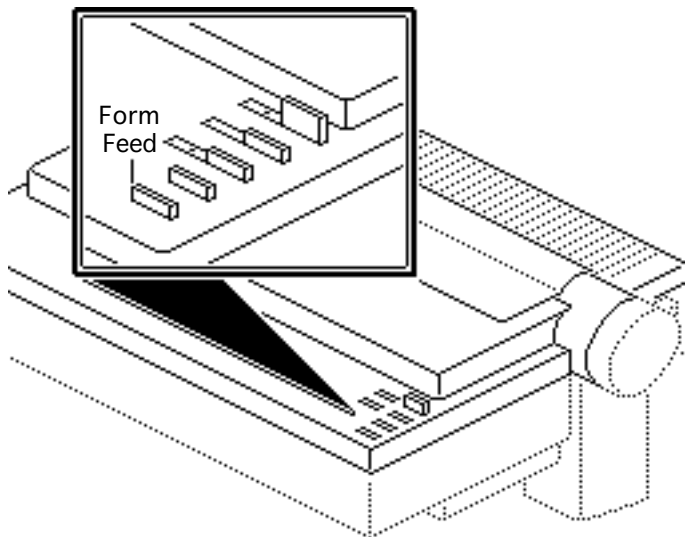

Form Feed - The form feed switch does not function unless the printer is in an off-line (deselected) state. When the form feed switch is pressed, the printer feeds paper until the next top of form is reached.



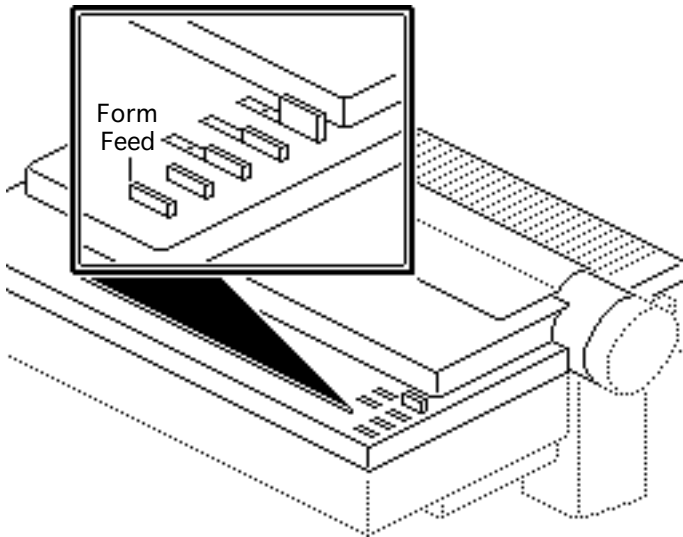

If the switch is pressed and no paper is present, the printer assumes a single sheet is being loaded. The printer feeds the single sheet up to the top of form position. If the switch is pressed and paper is present, the printer monitors the paper-off switch while feeding paper. If the printer detects an out-of-paper condition before the top of form is reached, the printer assumes that single sheets are being fed.



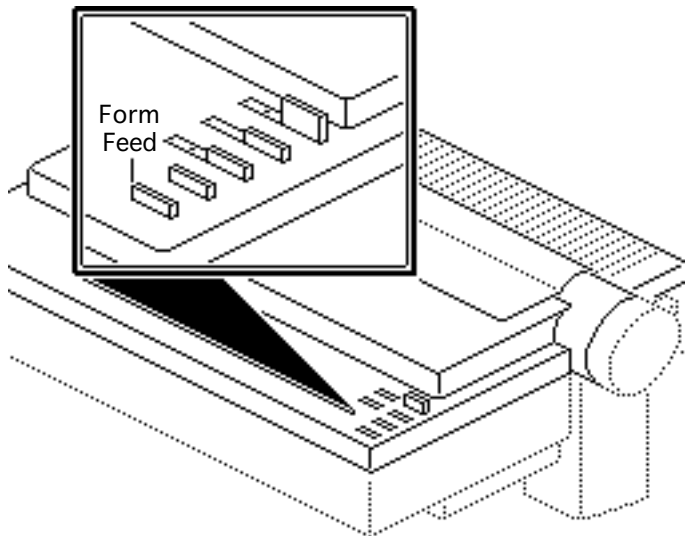

For the single sheet case, four inches of paper motion is added to the form feed to ensure that the page is properly ejected.



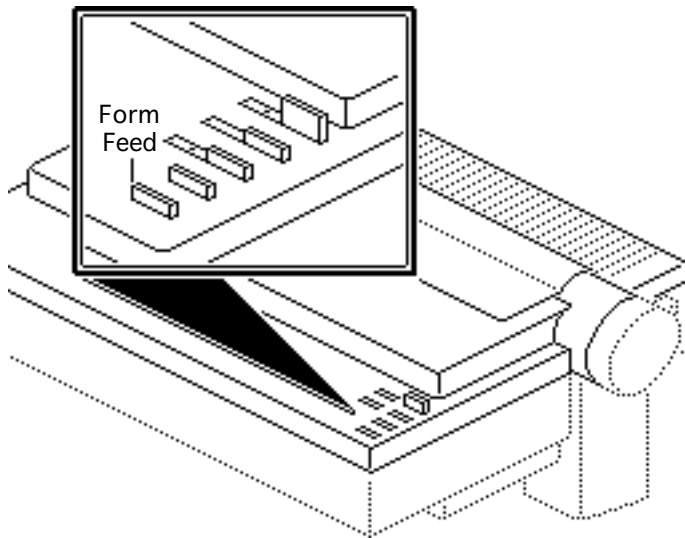

When an automatic cut-sheet feeder is present, the paper-loading sequence is slightly different. When the form feed is pressed with no paper present, the printer first rolls the platen to check if a single sheet had been inserted. If no paper is found, the printer loads a sheet from the automatic sheet feeder and positions it at the top-of-form position.



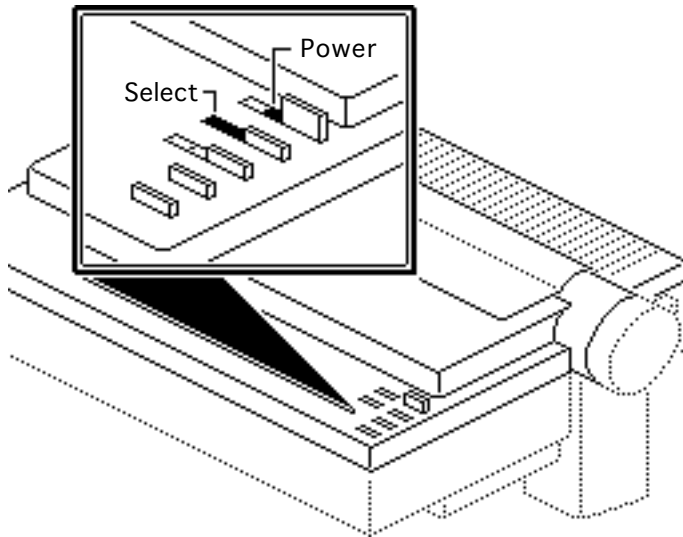

Indicators

Power - When lit, the power light indicates that power is on.

Select - When the select indicator is lit, the printer is online, in a ready state so that a transmission can take place.



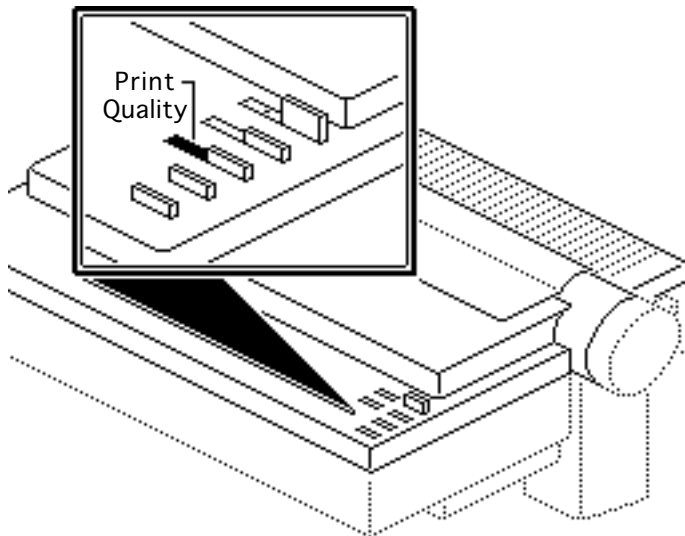

Print Quality - The print quality light indicates three modes of operation:

- **NLQ**—When both the left and right indicators are lit, the printer is in the Near Letter Quality print mode.
- **Draft**—When just the left indicator is lit, the printer is in the Draft print mode.



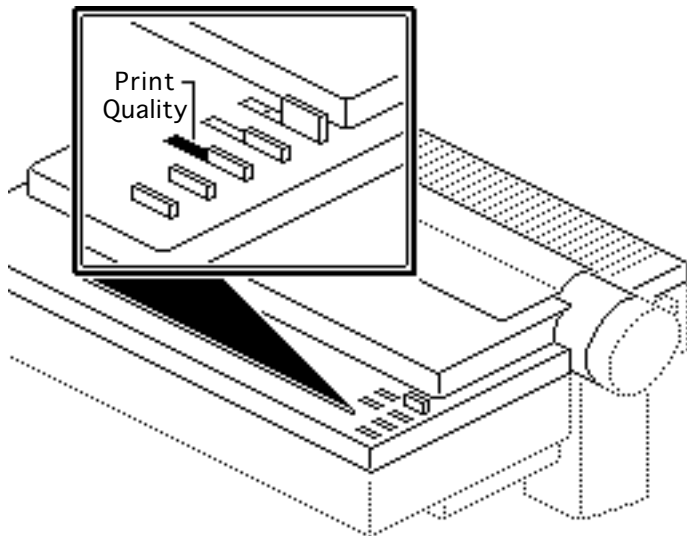

- Standard—If the right indicator is lit, the printer is in the Standard print mode. This is the default mode when the printer is turned on.



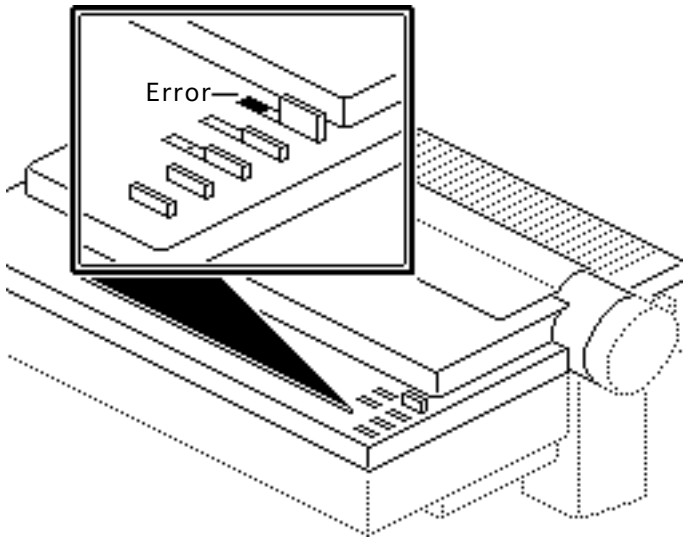

Error - The error light has three ways of indicating an error condition in the printer:

- If the error light comes on steady and stays on (and the select light goes off), the printer is out of paper.
- If the light blinks in a steady fashion (evenly spaced blinks), a cover is open or a left-margin error has occurred.



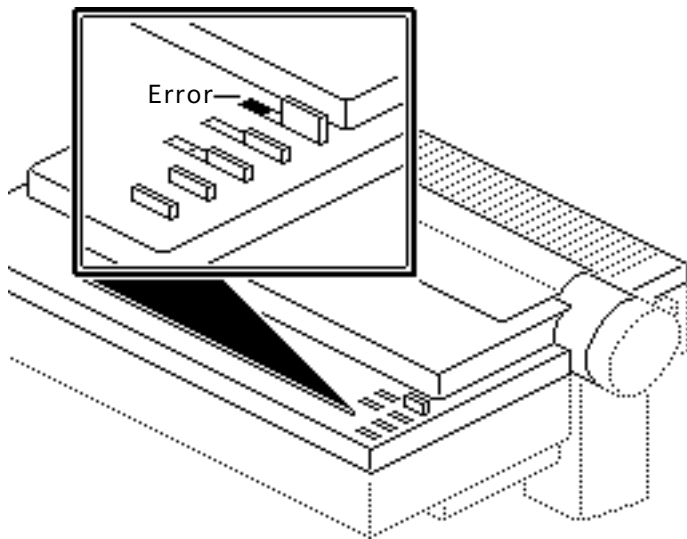

- If the light blinks in a repeating sequence of one short blink and a long blink, an interface communication or a RAM check error has occurred.





Specifications

ImageWriter II/L





Characteristics

Print Methods

Draft Mode: 250 characters per second (cps); 25 in. per second (ips) at 10 characters per in. (cpi)
Standard Mode: 180 cps; 18 ips at 10 cpi
NLQ Mode: 25 cps
100 in. per minute (ipm) at 80 dpi

Throughput

9 wires

Print Head

.0139 in. (.353 mm) nominal
Standard:.0118 in. (.300 mm) nominal
Japan:.0098 in. (.250 mm) nominal

Response Time

1440 Hz





Life	Standard: 4 by 108 strokes/wire Japan: 2 by 108 strokes/wire
Graphics Duty Cycle	25% minimum
Character Sets	ASCII (96 characters) Six European sets MouseText (32 characters)
Ribbon	Fabric ribbon Black or four-color (cannot use color with Kanji print head)





I/O Interfaces

Interface	Standard asynchronous
LocalTalk	With option board
Operation	Asynchronous, switch selectable; Data ready/busy (hardware handshake), or Xon/Xoff serial protocols
Connectors	Mini DIN-8 26-pin male (optional)
Data Format	Asynchronous serial/no parity bit shall be sent





Transmission Speed Switch selectable (300, 1 200, 2400, and 9600 baud)

Input Buffer 254K





Paper Feed

Method	Friction feed, adjustable tractors, and automatic single-sheet loader
Accessories	Automatic, cut-sheet feeder
Direction	Bidirectional (friction feed or tractor feed) Single sheets, sprocket feed, multicopy (original + three copies), single-width labels
Type	.002-.011 in. (.05-.28 mm) equivalent to 15-25 lb. bond
Thickness	3.5 in. minimum to “n” in. maximum (“n” is typically 11 or 14 for cut sheets)





Electrical

Line Voltage

USA/Japan: 85-132 VAC; 48-62 Hz

Europe/Australia: 185-265 VAC; 48-62 Hz

Stand-by: 20 W maximum

Operation: 180 W maximum





Physical

Dimensions

Height: 5 in.

Width: 17 in.

Depth: 12 in.

Weight

25 lb. maximum





Environmental

Temperature

Operation: 10–40°C

Storage: (one year) –40 to 47°C

Transit: (72 hours) –40 to 65°C

Relative Humidity

Storage: (six months) 10–95%





Troubleshooting

ImageWriter II/L





General

The Symptom Charts included in this chapter will help you diagnose specific symptoms related to your product. Because cures are listed on the charts in the order of most likely solution, try the first cure first. Verify whether or not the product continues to exhibit the symptom. If the symptom persists, try the next cure. (Note: If you have replaced a module, reinstall the original module before you proceed to the next cure.)

If you are not sure what the problem is, or if the Symptom Charts do not resolve the problem, refer to the Flowchart for the product family.

For additional assistance, contact Apple Technical Support.





Symptom Charts

Preliminary Check

Error light blinks

- 1 Verify that paper cover is secure.
- 2 Verify that paper cover magnet is in place.
- 3 Try known-good software.
- 4 Verify that option card dip switch SW2-4 is open/off with no card installed.

Select light off, error light on

- 1 Add paper or reset paper feed tray.
- 2 Verify that paper-out sensor works correctly (see Take Apart).

Select light does come on

- 1 Verify that paper cover is secure.
- 2 Verify that paper cover magnet is in place.
- 3 Verify that operation cable under top cover is secure.





No printing or garbled printing	<ol style="list-style-type: none">1 Check interface cable connection between printer and computer.2 Verify that DIP switches (2-1 through 2-4) are set correctly.
Software-specific problem	Try known-good software.
Prints OK for a while; then prints garbage	Set DIP switch SW2-3 to correct serial protocol.
Overprinting	Verify that program is set for correct line spacing and line length.
Light printing	<ol style="list-style-type: none">1 Change ribbon cartridge.2 Adjust impression lever (see Adjustments).3 Check for excessive play in carrier assembly. Make sure assembly is seated correctly (see Take Apart).





Erratic carrier motion, loud hum

Remove black tube-shaped shipping protection from carrier shaft.

Printing has squashed lines; misregistration problems with pin feed paper

- 1 For best print quality, instruct customer to place stack of paper behind printer and no more than three feet below printer. The paper should have a clear, unobstructed entry and exit path.
- 2 Verify that power cord or printer cable does not obstruct paper path.
- 3 Avoid printing in top and bottom one inch of paper (the areas where squashed line and misregistration problems will be most apparent).
- 4 Use 20-pound paper.





Print Quality

Compressed first or second line

- 1 Check position of paper behind printer to ensure there isn't anything blocking paper entry or exit.
- 2 Replace main board.

Print is darker or lighter on one side

Remove or install shims. See the Shims topic in the Additional Procedures chapter.

Top row of dots missing on printout

Perform "Ribbon Adjustment" (refer to Adjustments).

Power light on, no printing

- 1 Verify that ribbon frame assembly rides on the spiral ridge on color ribbon cam (see Adjustments).
- 2 Remove dot head and verify that pins in the connector on dot head board are not bent.
- 3 Go to "Indicator Lights" (see Flowcharts).





Missing dots

- 1 Check flexible cable connection.
- 2 Remove dot head and verify that pins in connector on dot head board are not bent.
- 3 Go to “Printing” (see Flowcharts).

Color self-test does not work

- 1 Verify that color ribbon detect switch operates and wires are unbroken. If defective, replace switch.
- 2 Top plate of carrier assembly (under ribbon cartridge) is not properly engaged with color ribbon cam (see Take Apart or Adjustments).

When printing from a Macintosh, characters sometimes appear smudged, or top of form gradually creeps down page in one-line increments

Verify that ImageWriter II/L driver software is the most current version.





Carriage Movement

Carriage doesn't move; LEDs are not lit

- 1 Replace main board.
- 2 Replace power supply board.

Carriage doesn't move; LEDs are lit

- 1 Replace main board.
- 2 Replace power supply board.

Carriage assembly moves to the left and does not return to center

- 1 Verify operation of switch on print head board. If switch is frozen or defective, replace print head board.
- 2 Verify that metal tab actuating left-side home position switch is bent correctly. Use a feeler gauge and bend tab 1 mm toward right side.
- 3 Replace main board.
- 4 Replace power supply board.
- 5 Replace flexible ribbon cable.





Carriage moves to the left and hums very loudly

- 1 Verify that flexible ribbon cable is properly connected to main board and to its connector under carriage assembly on print head board.
- 2 Replace flexible ribbon cable.
- 3 Replace power supply board.

Carriage assembly grinds or is difficult to move

- 1 Replace fuse on main board.
- 2 Replace power supply board.

Carrier binds on left side

Paper guide is too close to platen. Readjust paper guide.

Carrier intermittently locks up and gives light or dark print

Verify that rear of carrier assembly does not lift. If it does, it is not seated correctly in the guide rail. Gently push down on rear of carrier assembly until it snaps into place.





Self-test produces no carrier movement (LEDs are lit)

- 1 Remove mechanical assembly to ensure that wires to carrier motor are not pinched. If wires to carrier motor are worn, replace them.
- 2 Replace fuse on main board.
- 3 Replace main board.





Paper Feed

Grinding during paper feed

- 1 Remove platen knob to verify that there are no obstructions in the gears beneath knob.
- 2 Adjust paper guide (refer to Adjustments).
- 3 Replace line feed motor.
- 4 Replace main board.

Paper adjustment lever does not move

Verify that power on/off cable is not pinched between lever and metal frame or plastic case.





Miscellaneous

Hexadecimal data prints

Power printer off and then on.

Power supply goes bad repeatedly

Verify that power supply and motor wires are not pinched. If wires are pinched, lift mechanical assembly and reposition wires.

Ribbon jams or does not advance

- 1 Check gear box on carrier assembly. Verify that gear with cross (+) sticks through carrier assembly top plate and engages ribbon cartridge.
- 2 Verify that ribbon wire is properly installed in gear box
- 3 Verify that print head wires are not striking platen too hard. If they are, replace main board. If replacement of main board does not correct problem, reinstall original main board and replace print head.





Take Apart
ImageWriter II/L





Covers

No preliminary steps are required before you begin this procedure.

Caution: Review the ESD precautions in Bulletins/ Safety.

Note: This procedure covers the removal of the top cover, tractor cover, ribbon cover, and ribbon cartridge.

Note: To make reassembly easier, label all cables and connectors during the take-apart procedure.

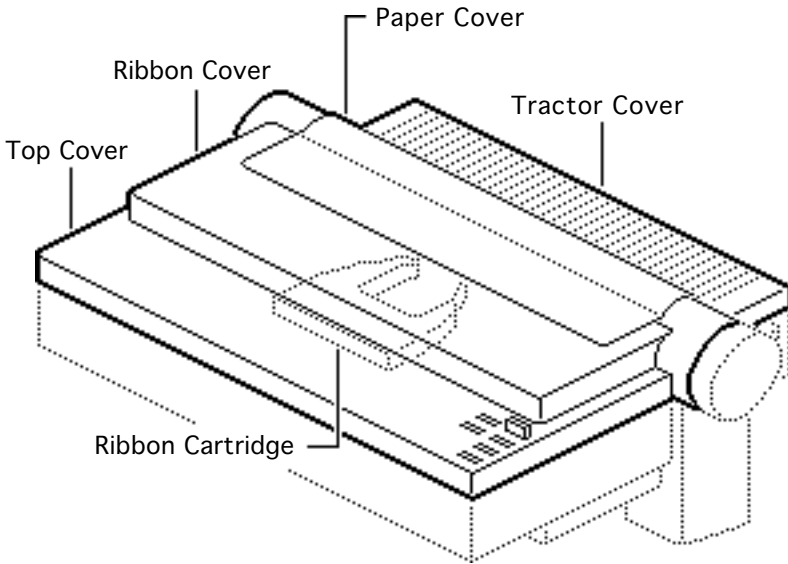

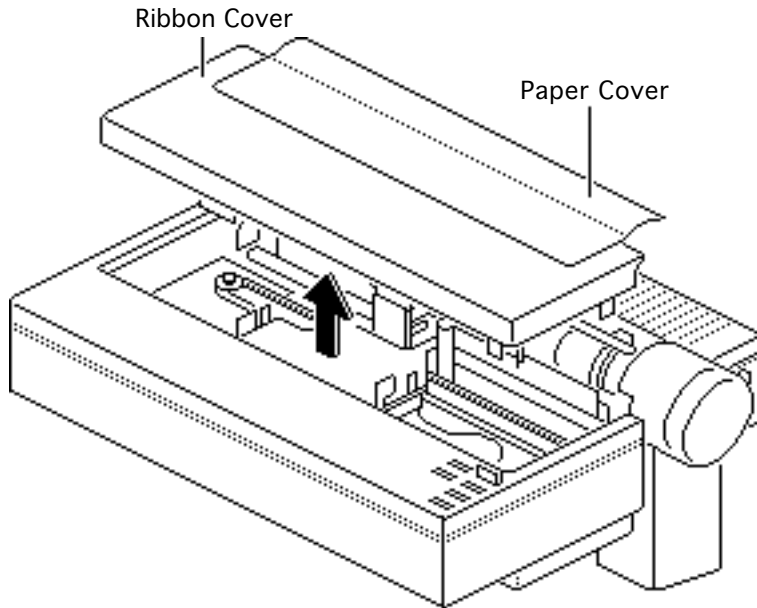

Paper Cover

Note: The paper cover assembly must be in place for the printer to work.

Gently pull the paper cover up and forward and remove the cover.

Replacement Note: Remove the paper cover from the ribbon cover only if the paper cover is broken and needs replacement. Push in the two tabs and separate the paper cover from the ribbon cover.





Ribbon Cartridge

Gently pull the tabs apart and lift the cartridge out.

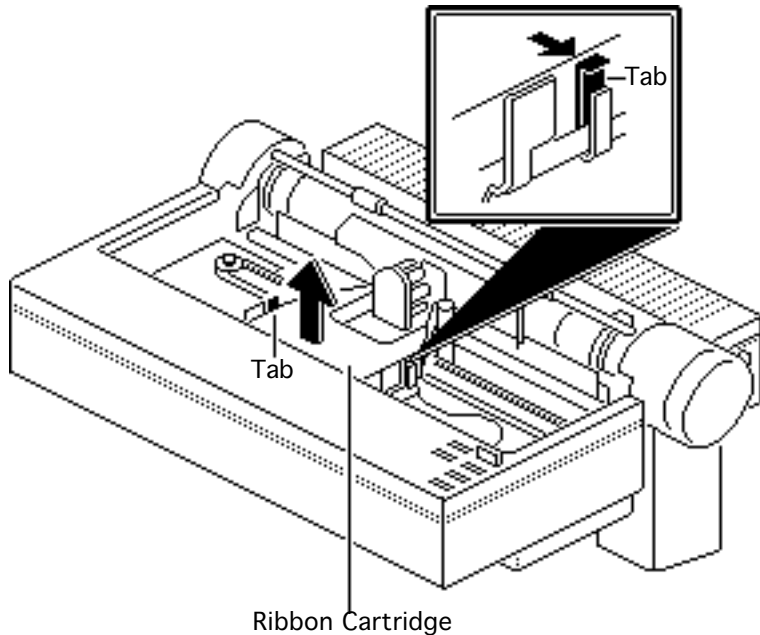



Top Cover

- 1 Push the carrier assembly to the far left.
- 2 Pull off the platen knob.
- 3 Loosen the two captive screws.

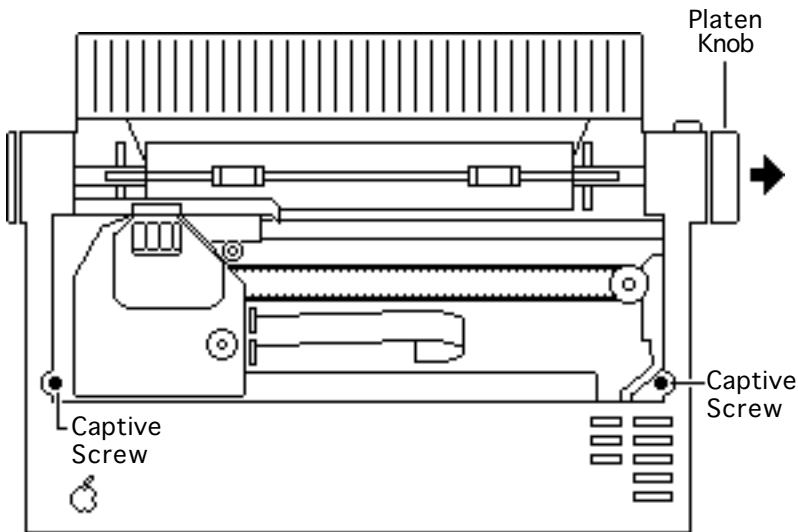

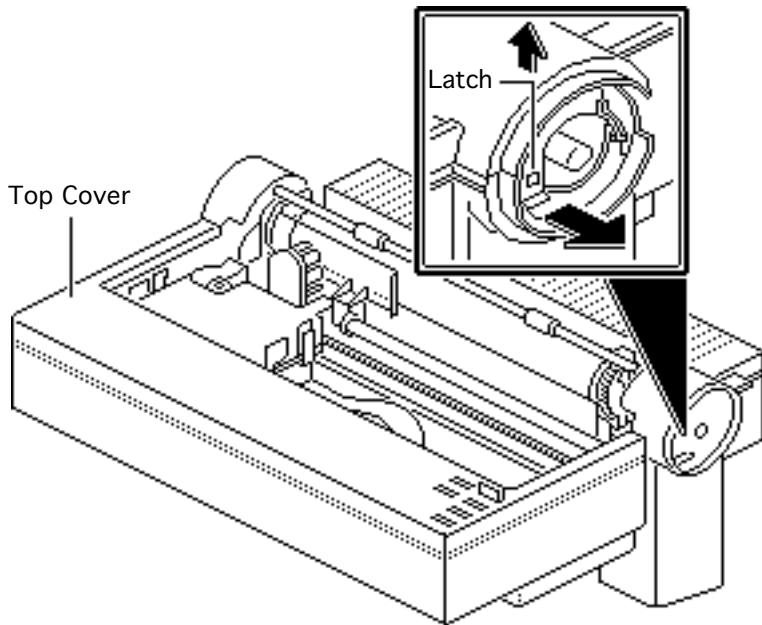

- 4 Grasp the top cover on the left at the part that goes over the leg.
- 5 Release the latch and lift the cover one inch.



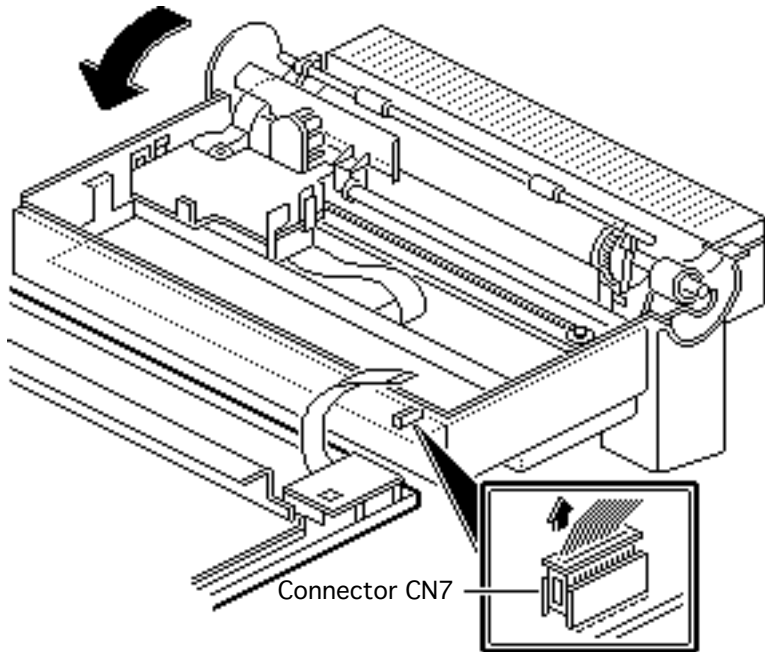

- 6 Gently rotate the cover toward the front and turn the cover over.
- 7 Using your thumb and forefinger, unlock connector CN7 and remove the ribbon cable.
- 8 Lift off the top cover.

Replacement Note:
Perform the self-test.





Tractor Cover

Gently pull the tractor cover up and forward until the cover snaps free.

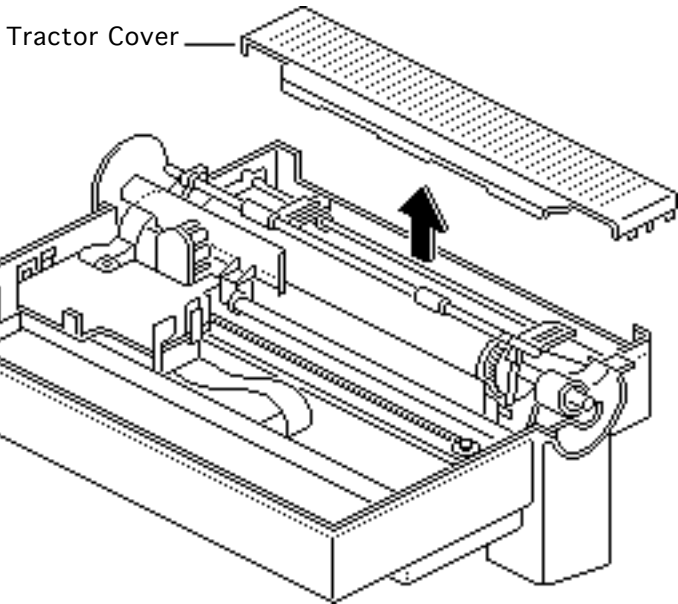



Operation Panel

Before you begin, remove the covers.

Caution: Review the ESD precautions in Bulletins/ Safety.

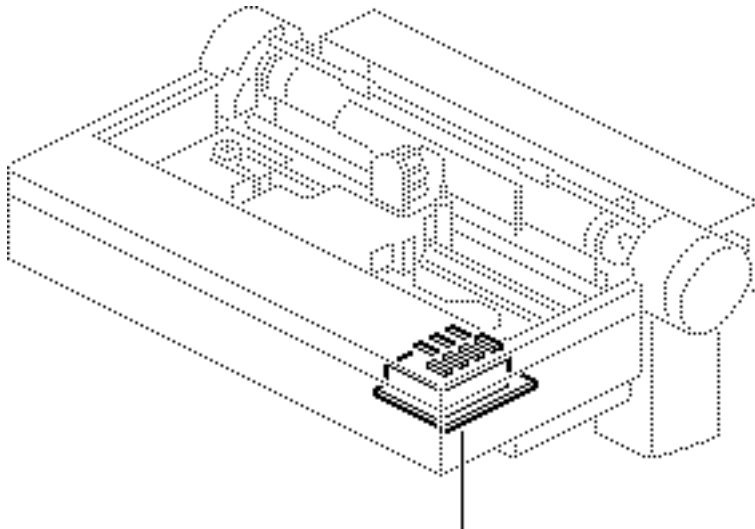

Operation Panel



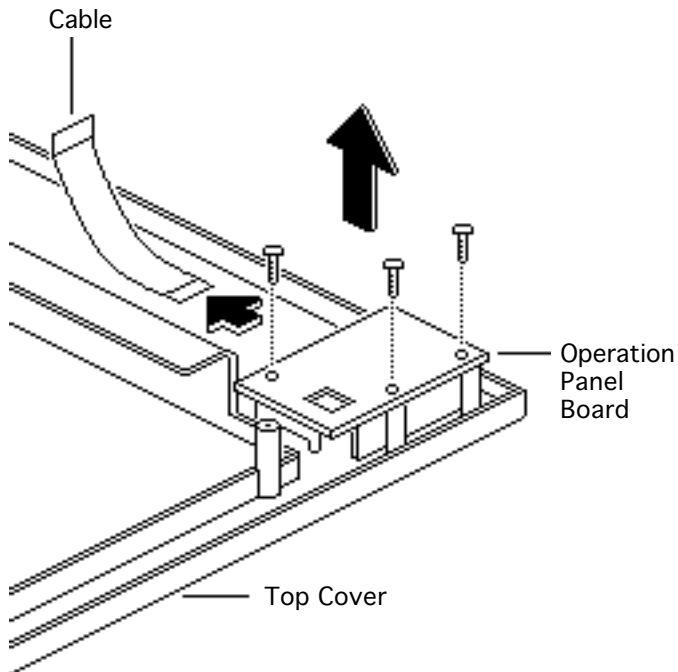

- 1 Remove the three screws and lift the operation panel board from the top cover.
- 2 Disconnect the cable from the operation panel board.



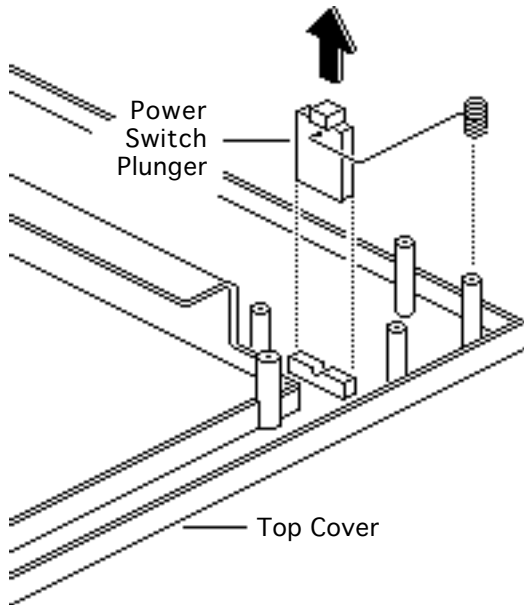

- Note:** To make reinstallation easier, observe the position of the power switch plunger and spring.

Remove the spring and power switch plunger from the top cover.

Replacement Note:
Perform the self-test.
See the Additional Procedures chapter.





Main Board

Before you begin, remove the following:

- Covers
- Option board

Caution: Review the ESD precautions in Bulletins/Safety.

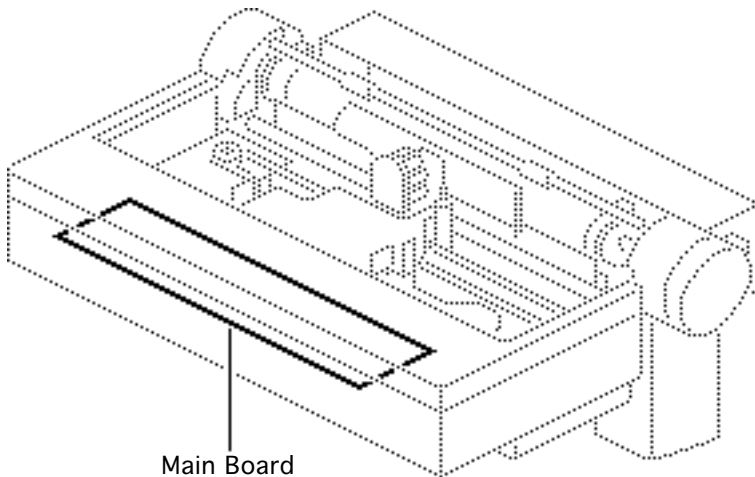



- 1 Disconnect the three cable connectors from the left side of the main board:
 - CN1
 - CN2
 - CN3

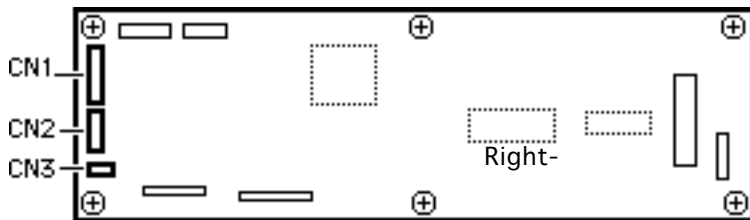

Main Board





Main Board

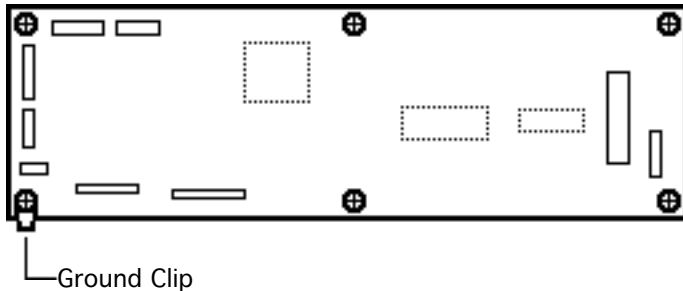

- 2 Remove the six screws.
- 3 Tilt the front half of the board up and gently lift the board partially out.

Replacement Note: Make sure to replace the ground clip on the screw at the lower left of the board.



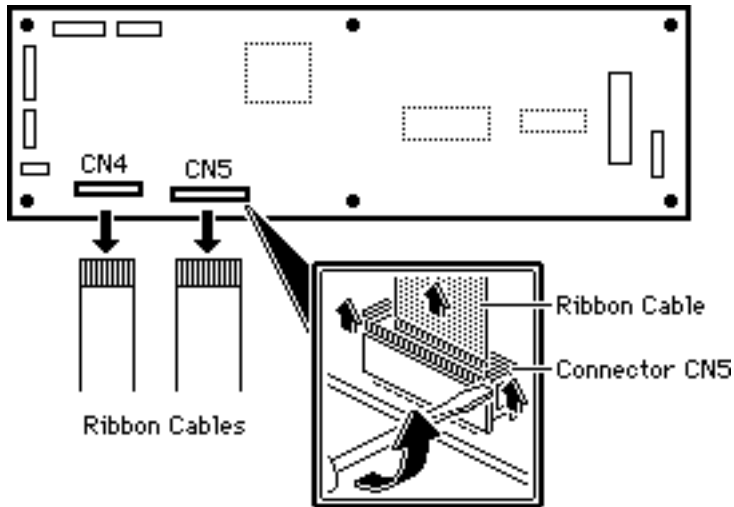

- 4 **Caution:** Make sure you release both sides of the connector before you pull out the ribbon cable.

Using a small screwdriver, unlock each side of connectors CN4 and CN5 and remove the two ribbon cables.

Replacement Note:
Perform the self-test.





Print Head and Paper Guide

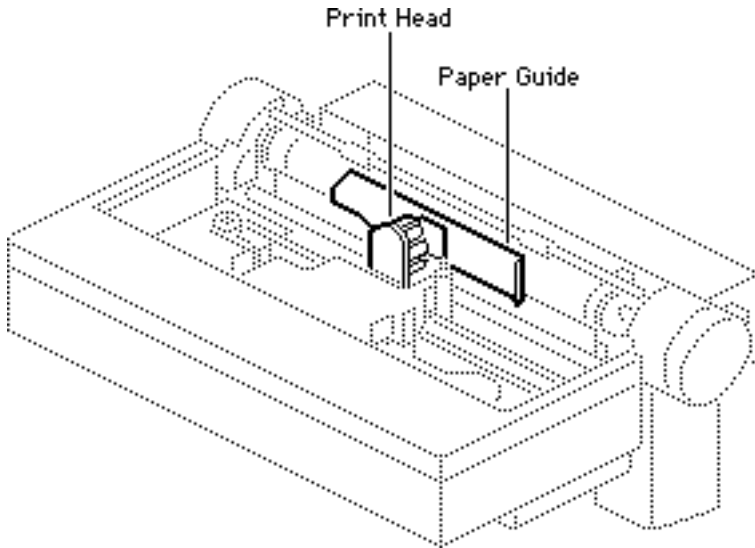

Before you begin, remove the covers.

Caution: Review the ESD precautions in Bulletins/ Safety.

Note: The print head does not have to be removed in order to remove the paper guide.





Print Head

- 1 Lift the paper bail to its highest position.
- 2 Set the paper thickness lever to its widest setting.

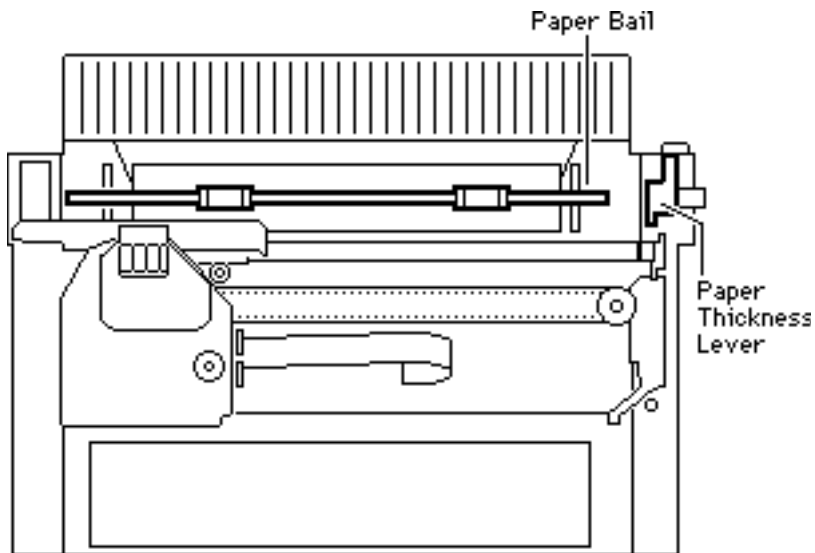

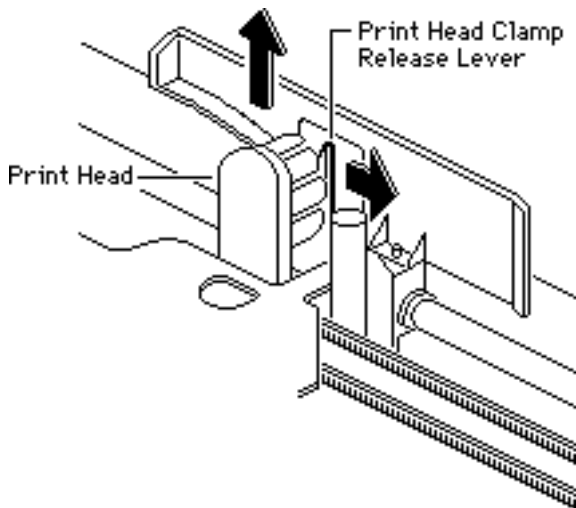

- 3 Gently push and hold aside the white print head clamp release lever and slowly lift the print head straight out of the connector.

Replacement Note:
Perform the self-test.





Paper Guide

Remove the two screws and lift out the paper guide.

Replacement Note: Adjust the paper guide. See the Adjustments chapter.

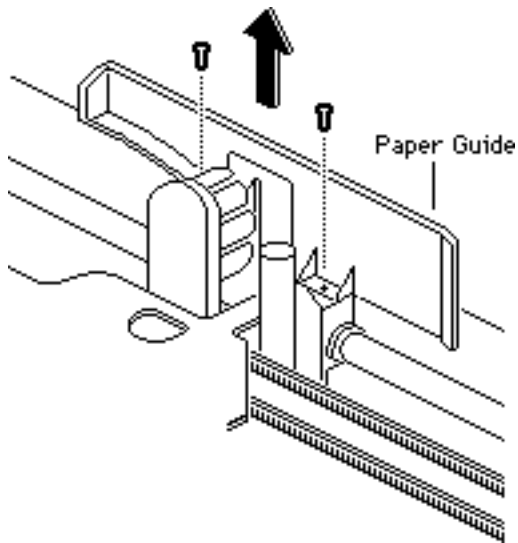



Ribbon Cam Assembly

Before you begin, remove the covers.

Caution: Review the ESD precautions in Bulletins/ Safety.

Note: There are two versions of the ribbon cam assembly. One has a plastic cap and the other has a hex nut, without the cap.

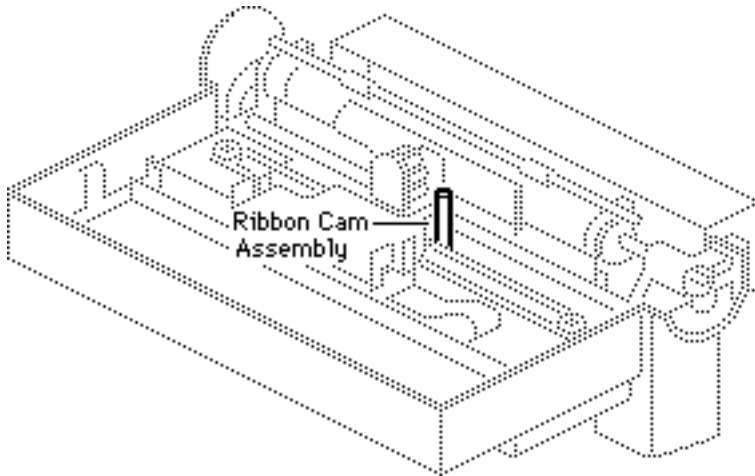

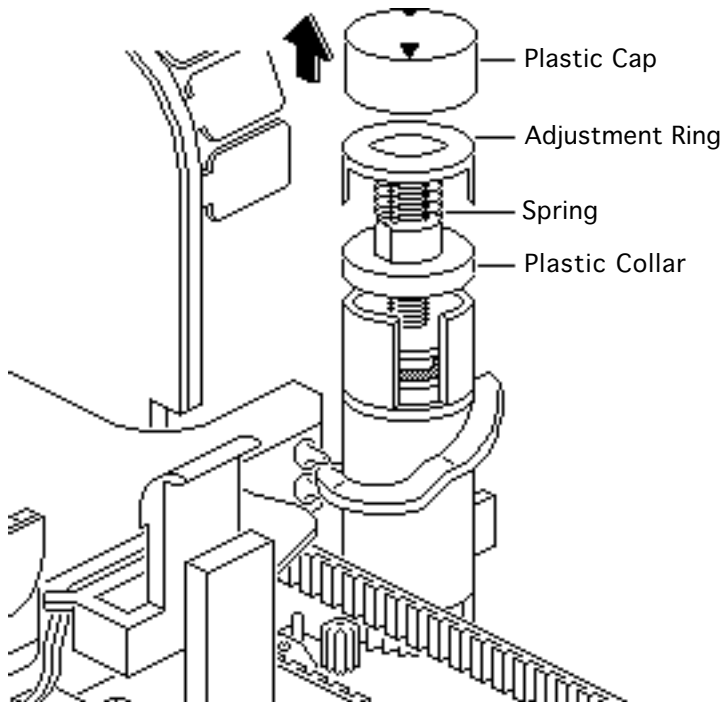

- 1 Unscrew the plastic cap from the ribbon cam.
- 2 Remove the red adjustment ring and the spring.
- 3 Remove the plastic collar.



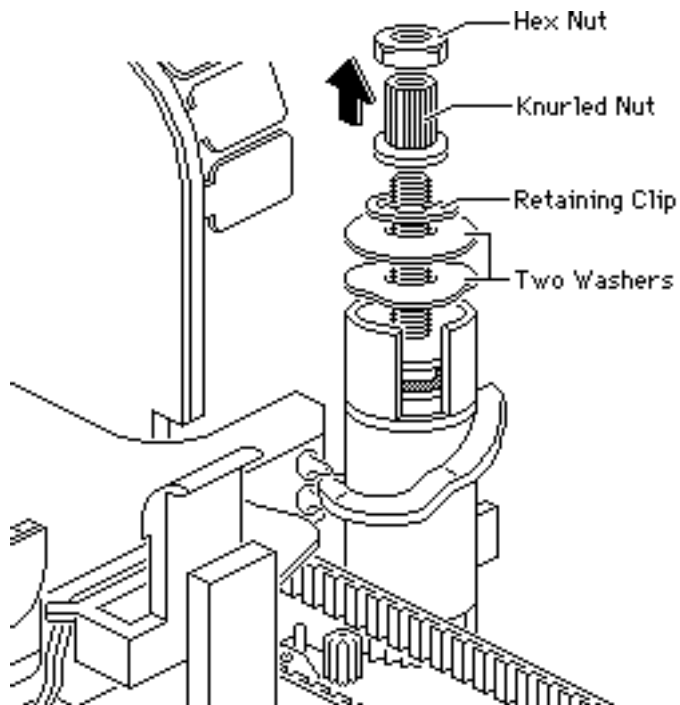

- 4 **Note:** For versions with the hex nut, remove the nut and proceed with the rest of the procedure.

Using small needlenose pliers, remove the retaining clip and two washers.

- 5 Remove the vertical knurled nut.



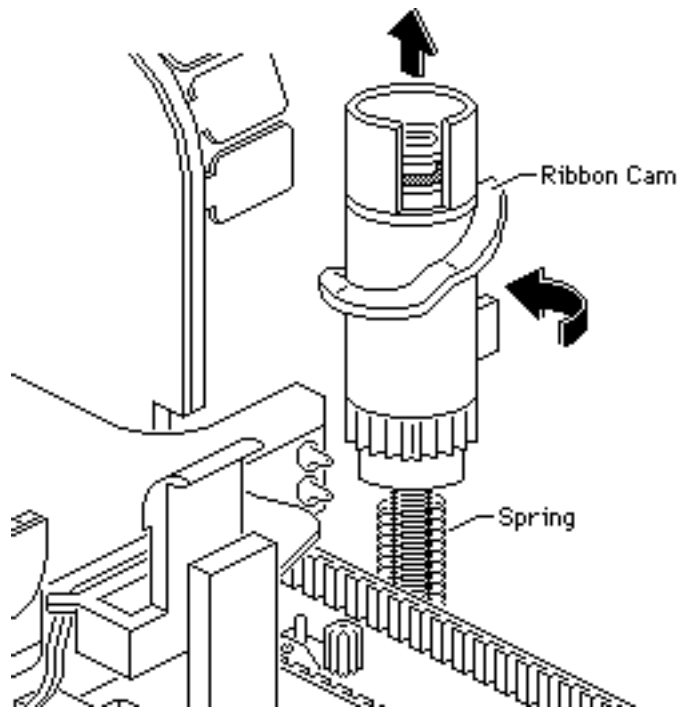

- 6 Turn and lift off the ribbon cam.
- 7 Remove the spring.



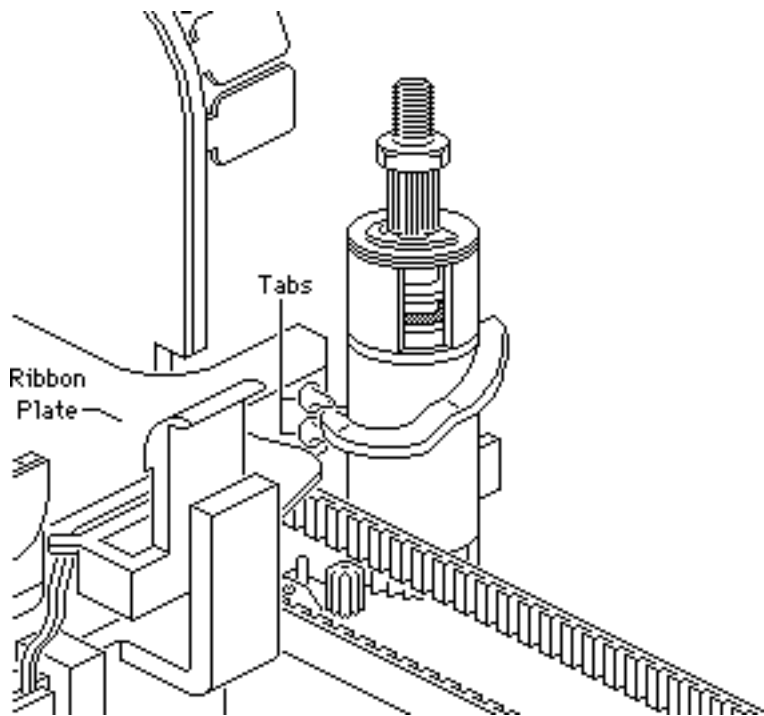

Replacement Note: When you replace the cam, set the cam at its lowest setting. Verify that the two tabs of the ribbon plate are riding on the cam ridge. Improper positioning of the cam can cause poor-quality prints or no prints.

Replacement Note: Adjust the ribbon cam (see “Ribbon Cam” in the Adjustments chapter).





Carrier Assembly Top Plate

Before you begin, remove the covers.

Caution: Review the ESD precautions in Bulletins/ Safety.

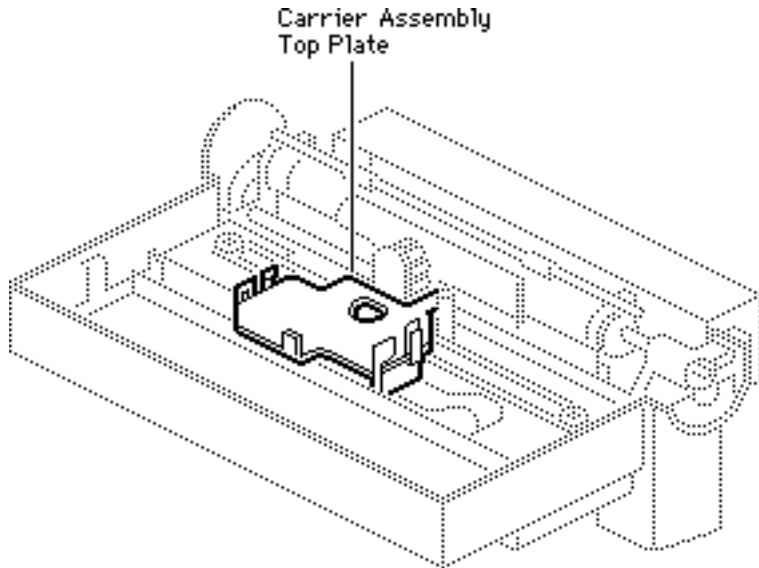

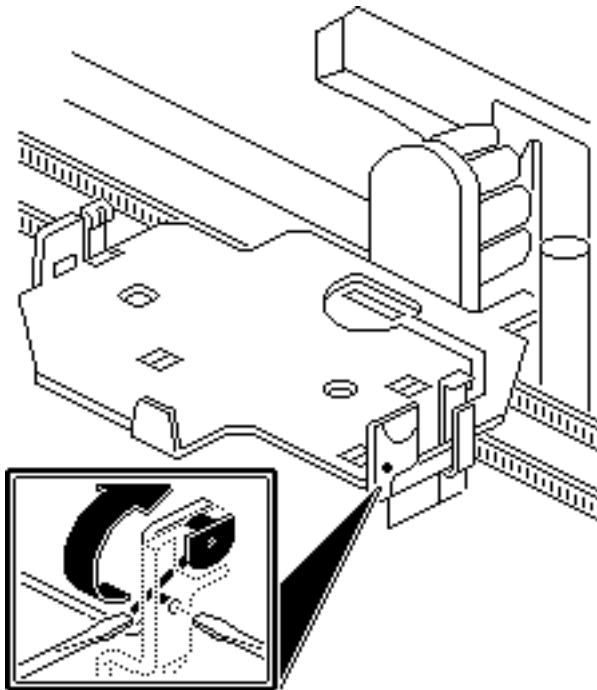

- 1 **Caution:** Do not use force when you remove the black plastic arms. You will break them.

Using a small flat-blade screwdriver, push out the black bearing arm.

- 2 With another small screwdriver, gently pry the arm upward at a slight angle.
- 3 Move the small arm to the top.



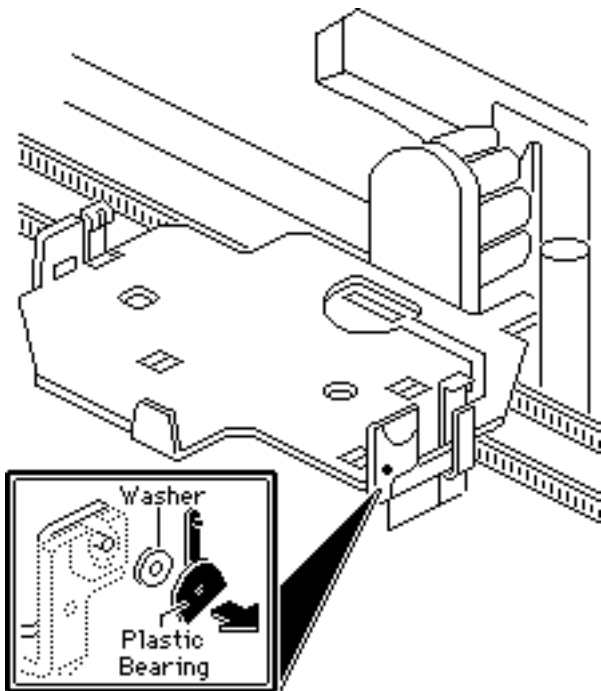

- 4 Gently pull the plastic bearing straight out and remove the small washer.
- 5 Repeat for the right side.

Replacement Note: The bearings are not interchangeable.



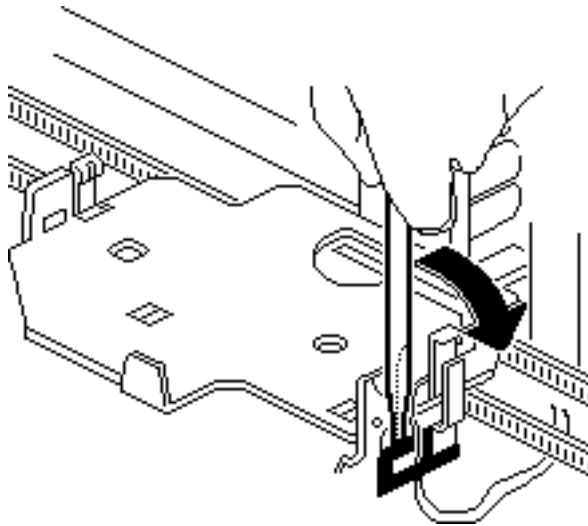

- 6 Gently pry the top of the wire clamp from the carrier assembly and remove the color ribbon detect switch wires from the clamp.





- 7 Using a jeweler's screwdriver, push the gear assembly tabs toward the center of the ribbon plate and lift off the top plate. Leave the gear assembly in the carrier housing.

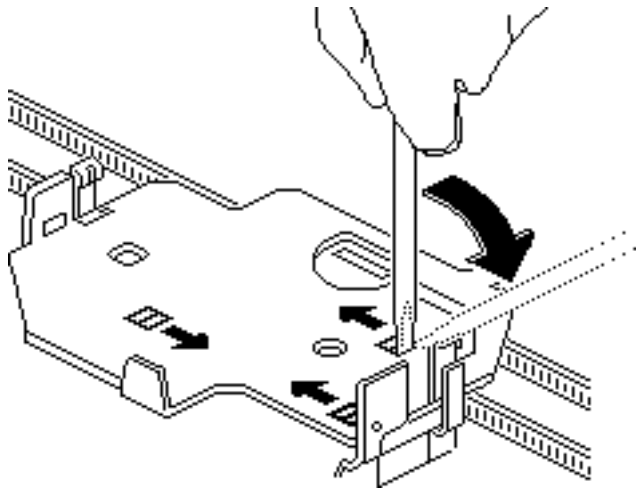



Color Ribbon Detect Switch

- 1 **Note:** Do not bend the plastic tabs that hold the wires.

Carefully pry the wires out of the embedded track of the top plate.

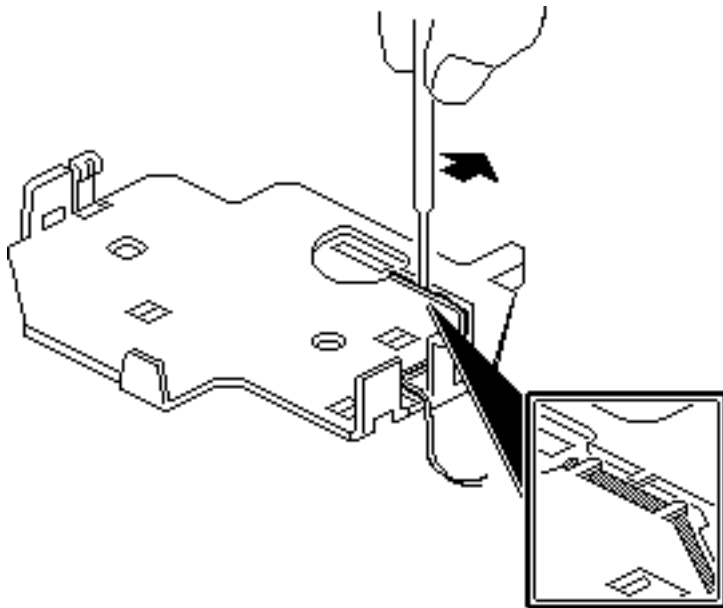

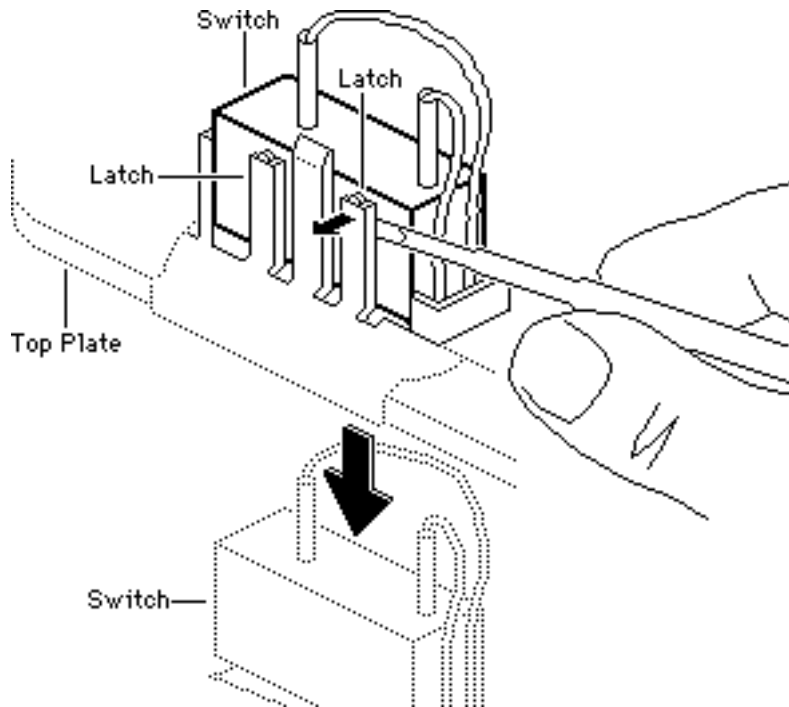

- 2 Turn over the top plate. Using a small screwdriver, gently pry the four latches and at the same time push down on the bottom of the switch so the switch comes out from the top of the plate.





Ribbon Wire and Gears

Before you begin, remove the following:

- Covers
- Carrier assembly top plate

Caution: Review the ESD precautions in Bulletins/Safety.

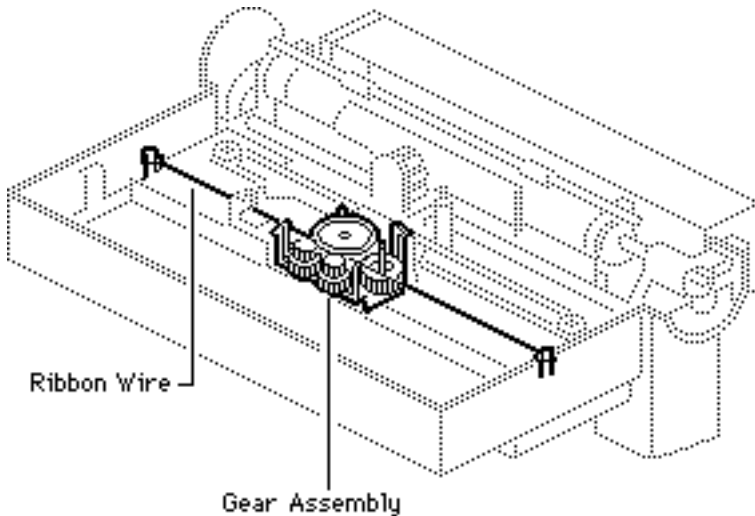



- 1 Unhook the ribbon wire from the right side of the frame, and then from the left side of the frame. Remove the ribbon wire.

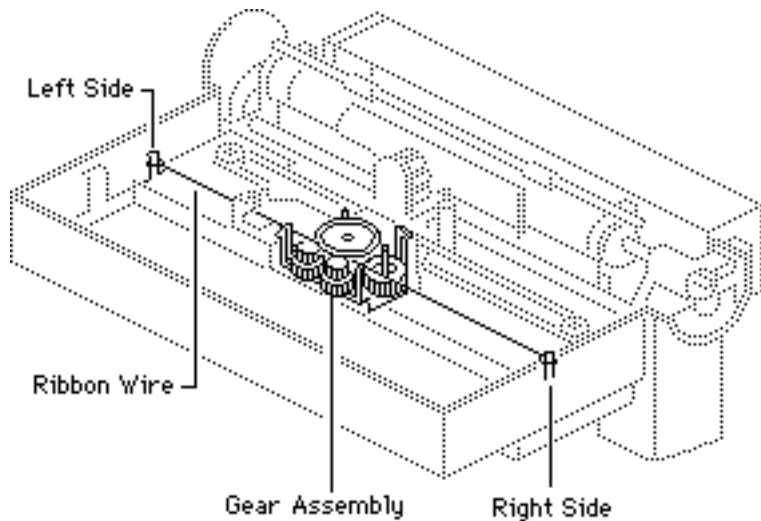

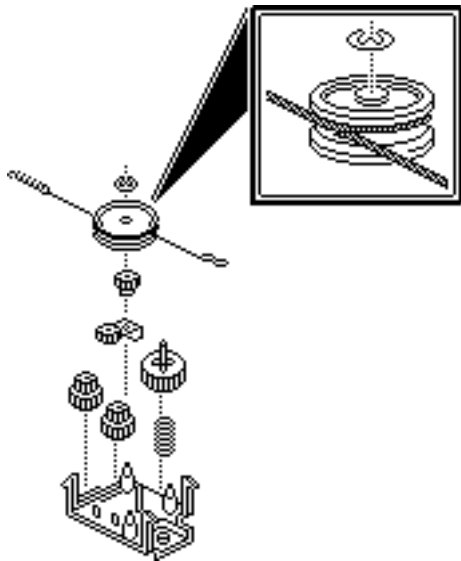

- 2 Lift the gear assembly from the carrier housing.

Replacement Note:
Perform the self-test.

Replacement Note: Be sure the wire is rewrapped with the wire crossing in front of the gear. Then secure the wire on the right side.





Drive Belt/Carrier Motor

Before you begin, remove the covers.

Caution: Review the ESD precautions in Bulletins/Safety.

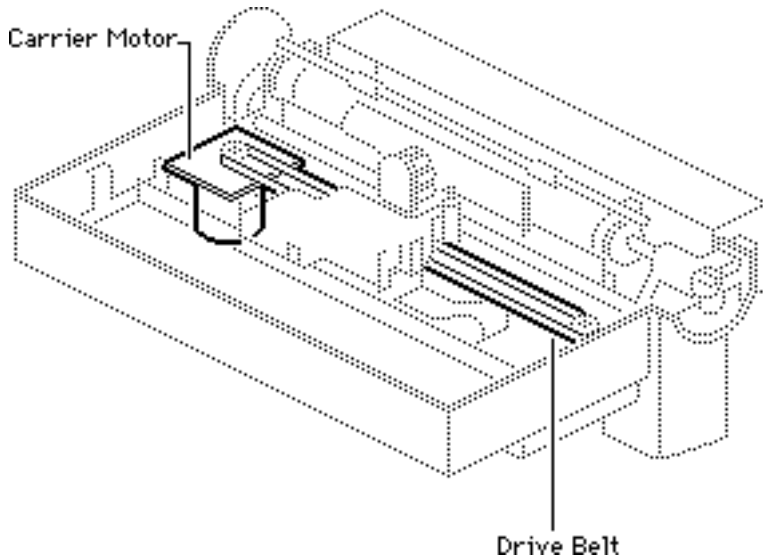

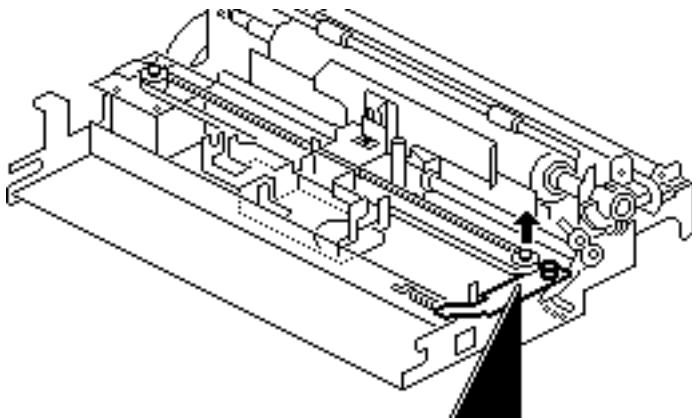

Drive Belt

- 1 Loosen the screw on the pulley tension plate. Do not remove the screw.
- 2 Using a large screwdriver, push toward the right side and remove the drive belt from the right-side pulley.

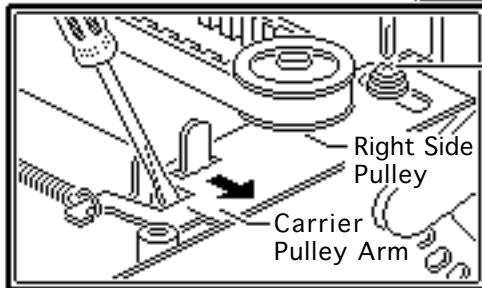

Adjustment
Screw

Right Side
Pulley

Carrier
Pulley Arm





- 3 Remove the drive belt from the left-side pulley.

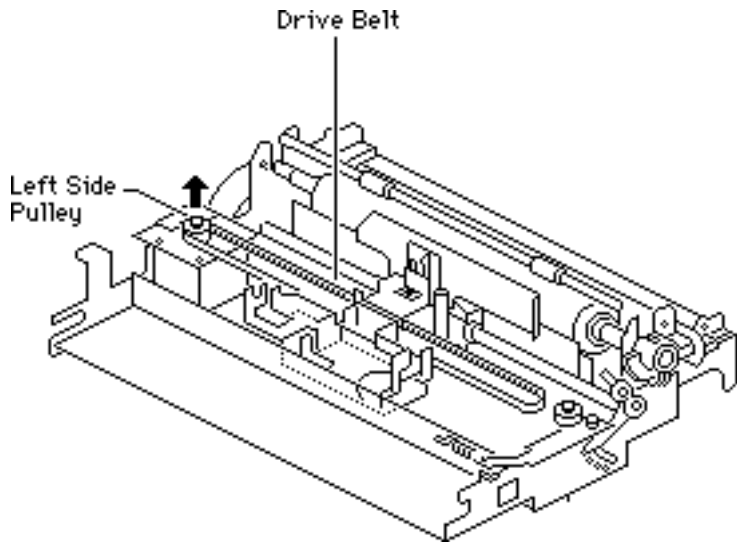

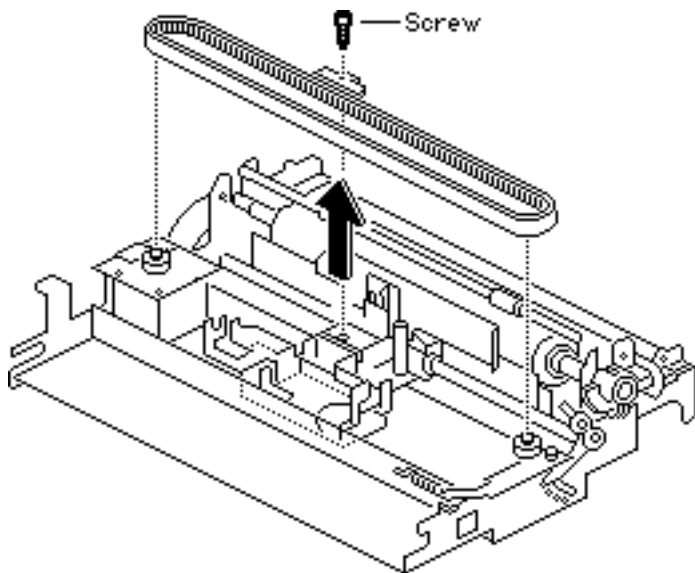

- 4 Remove the screw from the retaining clip.
- 5 Using a small flat-blade screwdriver, pry up the retaining clip from the housing and remove the belt.

Replacement Note: The retaining clip is glued to the drive belt.





Carrier Motor

Remove the three screws that secure the carrier motor and remove the carrier motor.

Replacement Note: Inspect the self-adhesive damping pad between the motor and the frame. Replace the pad if necessary.

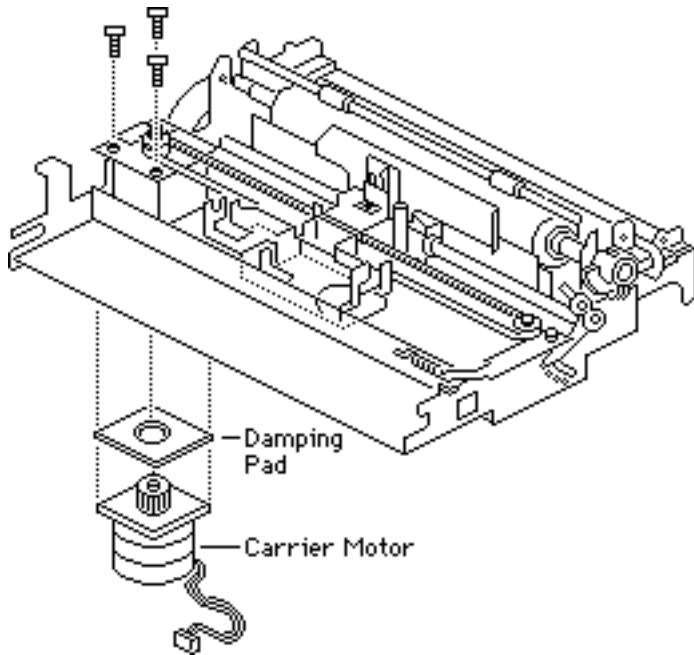



Mechanical Assembly

Before you begin, remove the covers.

Caution: Review the ESD precautions in Bulletins/ Safety.

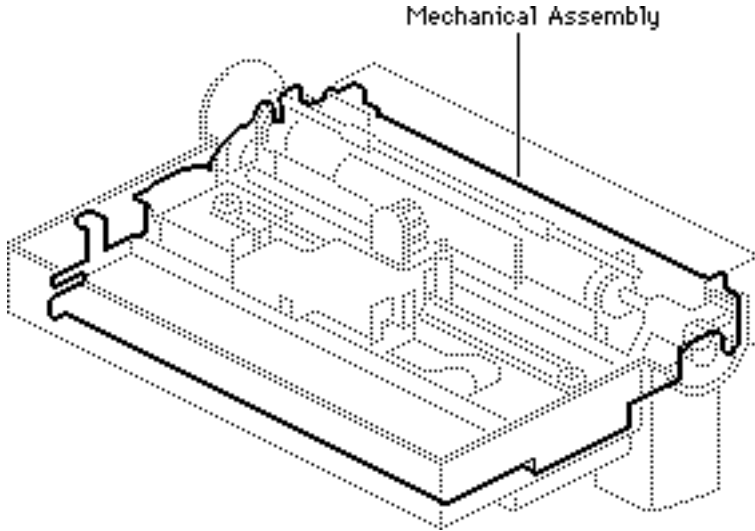

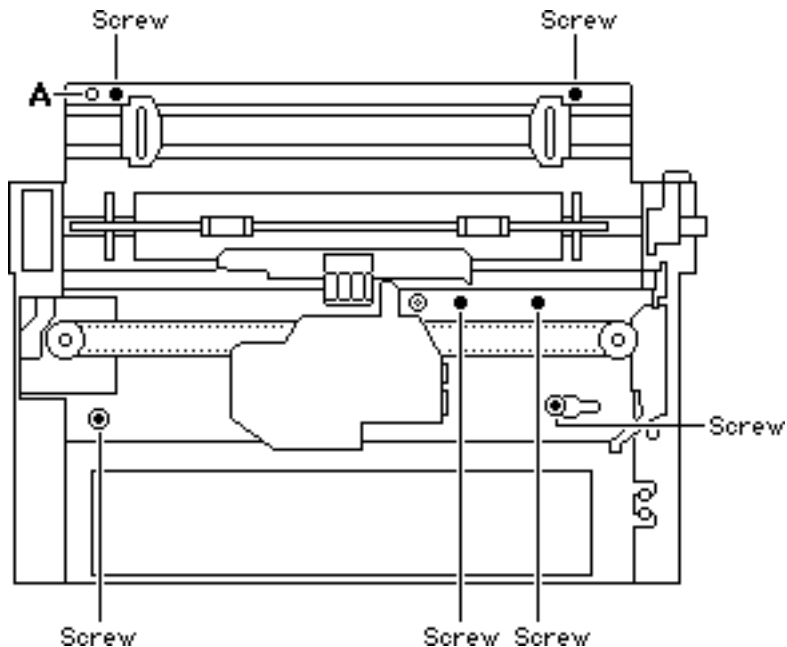

- 1 Remove the six screws that hold the mechanical assembly to the bottom case.

Note: Do not remove screw A at the back of the assembly nearest the left side. This screw holds the sub board in place.



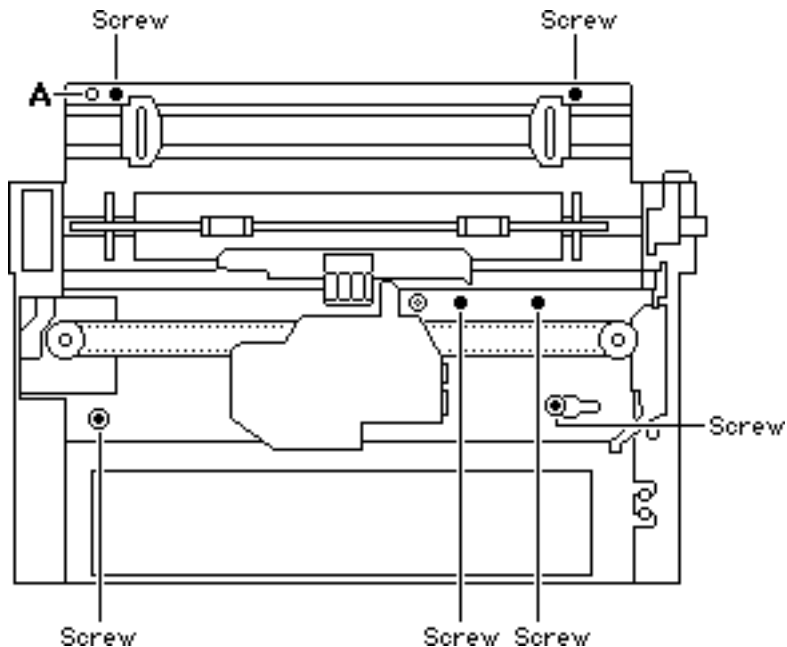

Replacement Note: Two screws make the ground connection between the power supply plate and the rest of the mechanical assembly. If you do not replace both screws, the ground is not complete and logic errors or hazards can result.





- 2 Remove the two screws that hold the power switch cable in place.
- 3 If the main board is in the printer, disconnect the connector at CN3 on the main board.

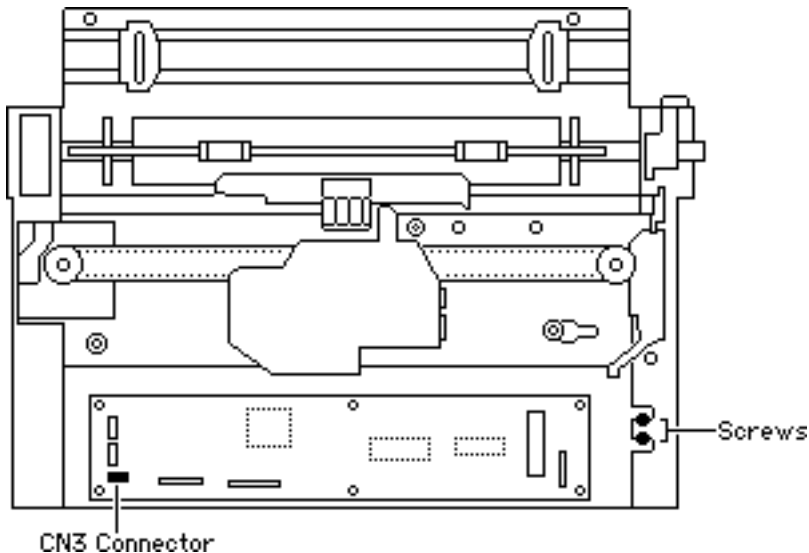

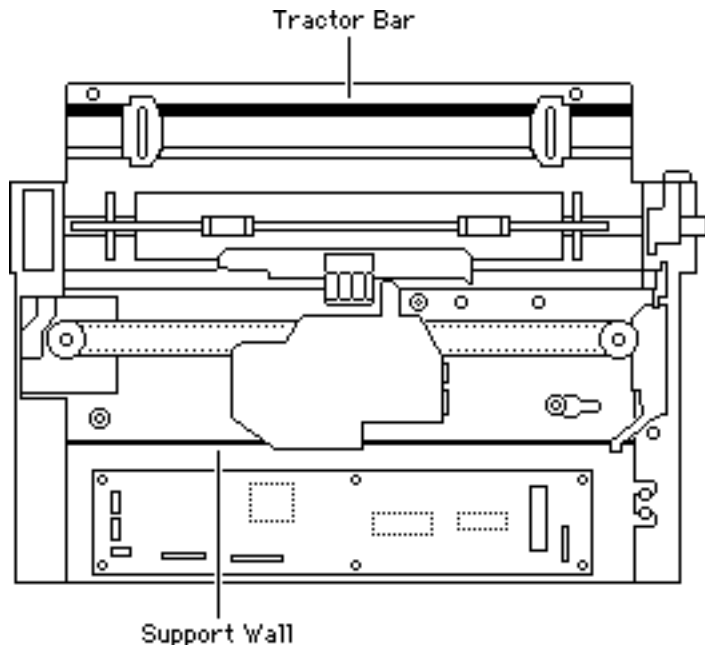

- 4 Grasp the middle of the back tractor bar. With the other hand hold the middle of the support wall and lift the entire mechanical assembly from the case.



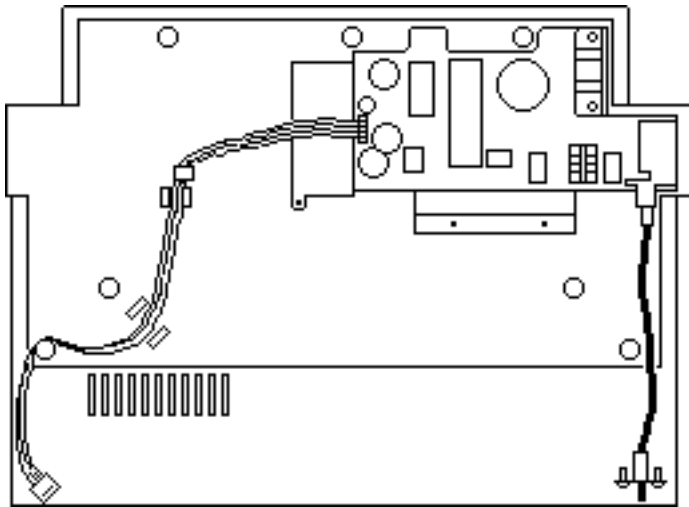

Replacement Note: As you lower the assembly into place, make sure to route the power supply cable correctly and to align the power switch cable correctly. Correct placement will ensure that the cables do not pinch when you lower the assembly into place.





Flexible Ribbon Cable

Before you begin, remove the following:

- Covers
- Mechanical assembly
- Carrier assembly top plate

Caution: Review the ESD precautions in Bulletins/ Safety.

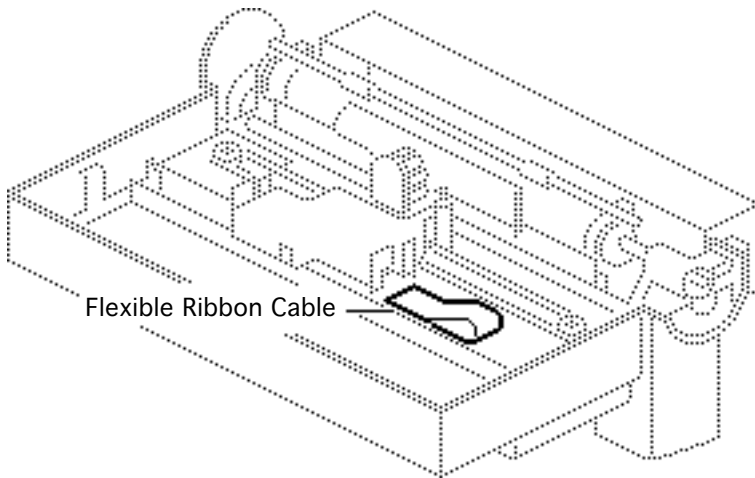

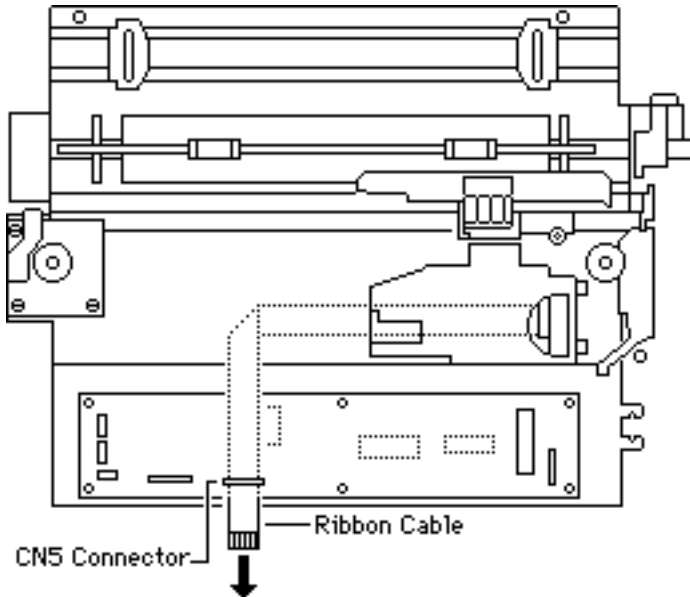

- 1 Remove the ribbon cable from connector CN5 on the main board.
- 2 Move the carrier assembly toward the right side of the carrier until the assembly is lined up with the right edge of the board.





- 3 Slightly lift up the front of the carrier assembly until you hear a snap.

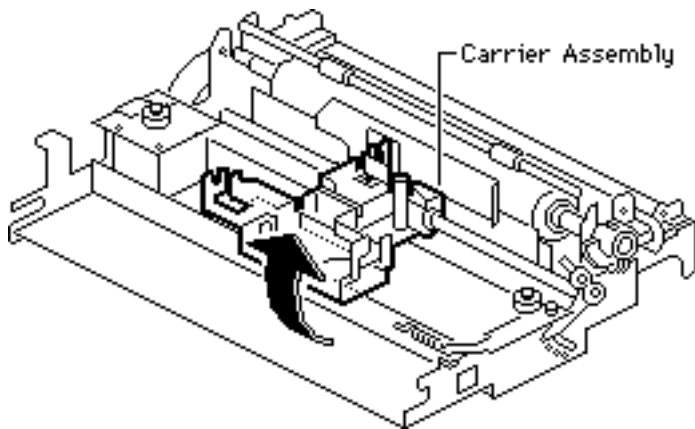

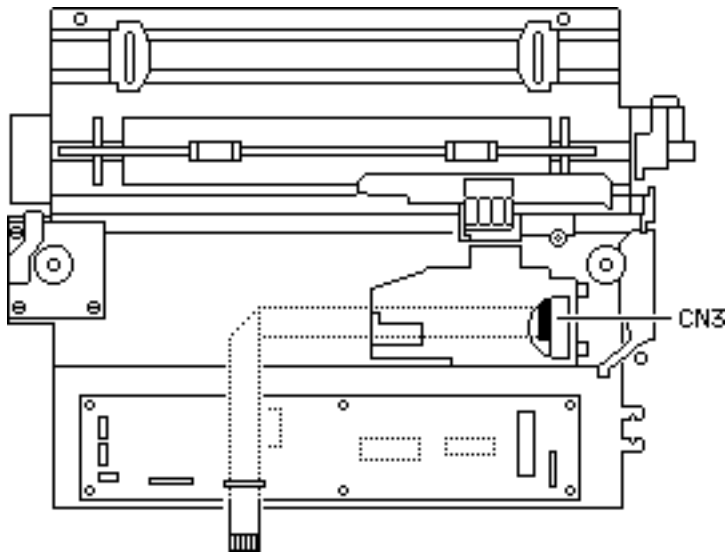

- 4 **Caution:** Do not force the flexible cable loose or you will damage the cable.

Using a small screwdriver, gently turn the screwdriver until connector CN3 pops up 1/8 inch. Remove the flexible cable.



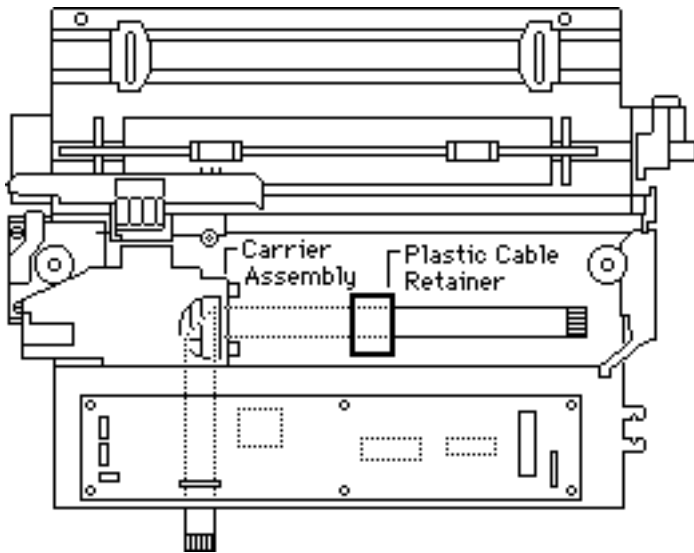

- 5 **Note:** The cable may be glued to the bottom of the case. You may need to pry the cable loose.

Push the carrier assembly to the far left and remove the cable retainer.





Ribbon Motor Assembly

Before you begin, remove the following:

- Covers
- Carrier assembly

Caution: Review the ESD precautions in Bulletins/ Safety.

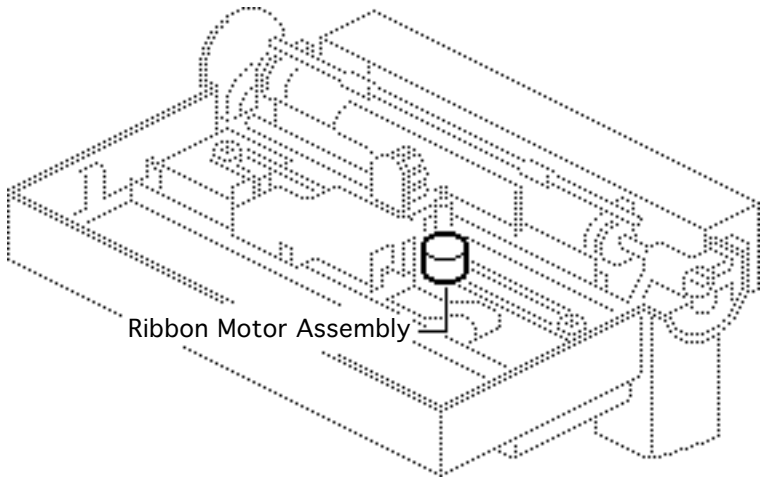

Ribbon Motor Assembly



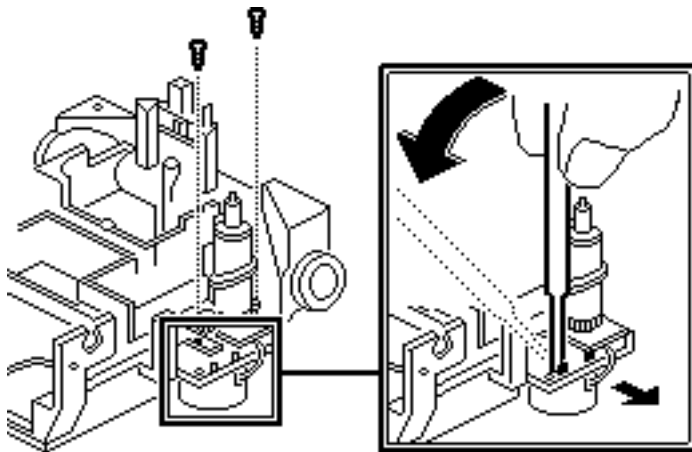

- 1 **Note:** Observe the position of the connector and the wires on the ribbon motor assembly.

Remove the two mounting screws, insert a jeweler's flat-blade screwdriver behind the small black extension, and gently pry the motor out.



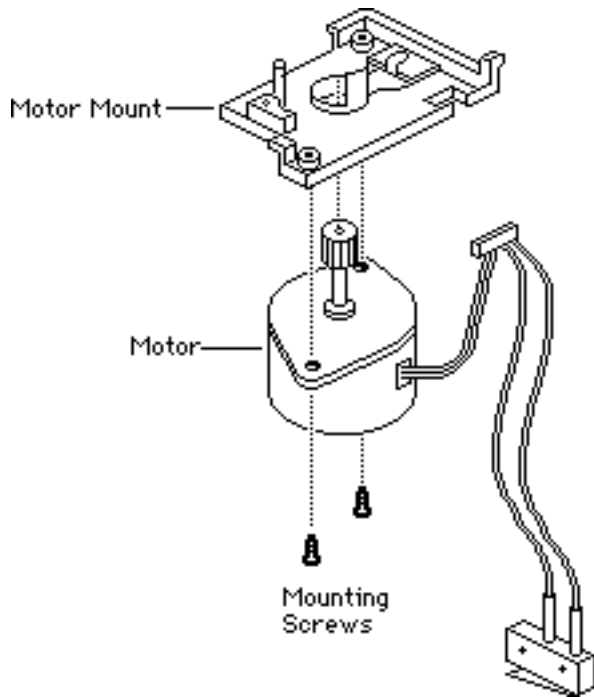

- 2 Remove the two mounting screws and remove the motor from the motor mount.





Power Supply Board

Before you begin, remove the following:

- Covers
- Mechanical assembly

Caution: Review the ESD precautions in Bulletins/ Safety.

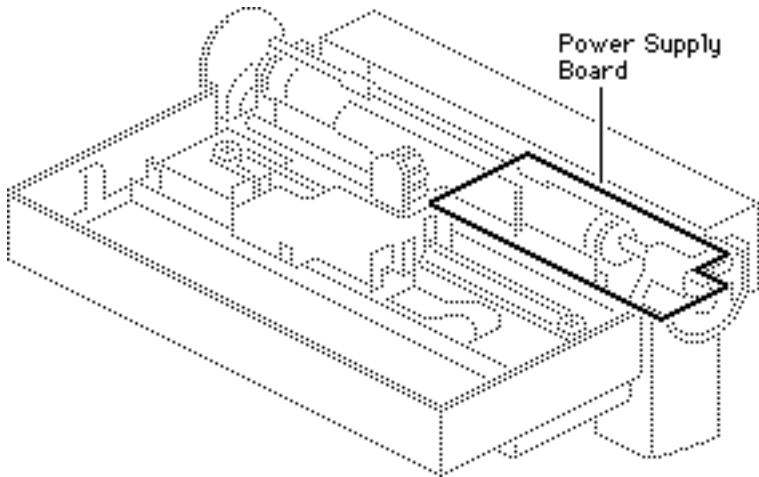

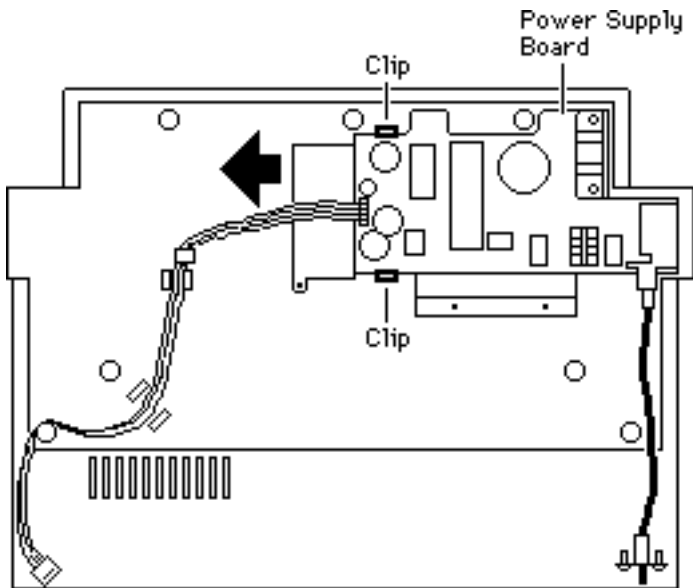

- 1 Slide the power supply board 1/8 inch to the left.
- 2 Pry back the two clips that hold the board to the bottom case and lift the board from the case.





Ground Plate

- 1 Remove the two screws from the AC plug receptacle, and remove the metal bracket.
- 2 Remove the screw that holds the ground wire to the ground plate.
- 3 Bend the two tabs until they are parallel with the board. Pull the board away from the metal ground plate.

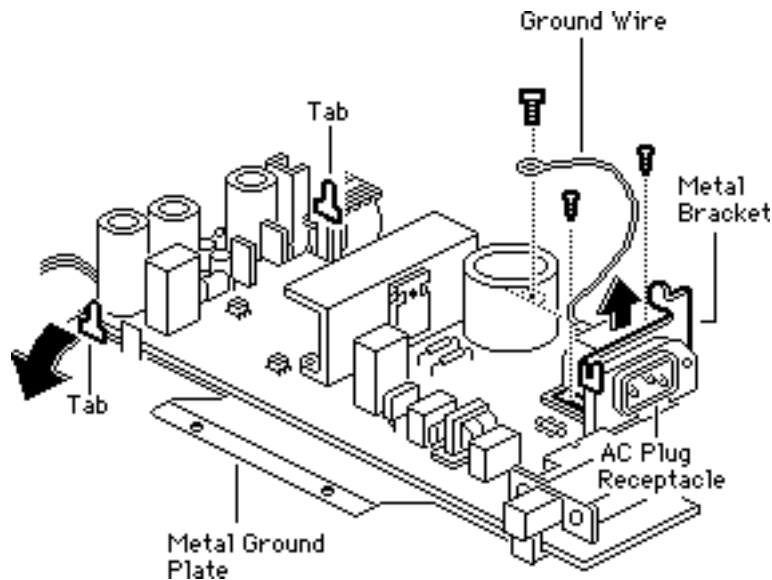

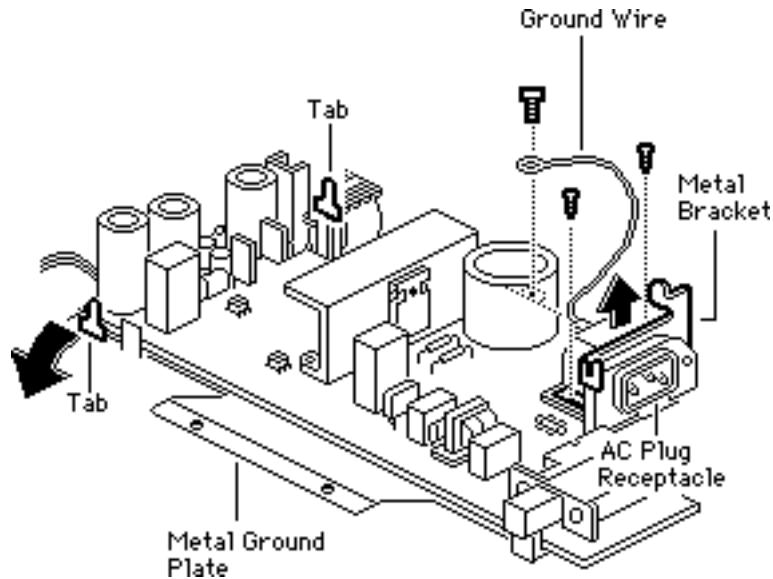

Replacement Note: When you replace a power supply board, you must remove the ground plate and the on/off switch cable and use them on the new power supply board.





On/Off Power Switch Cable

Remove the two screws from the on/off power switch cable. Lift the cable off the power supply board.

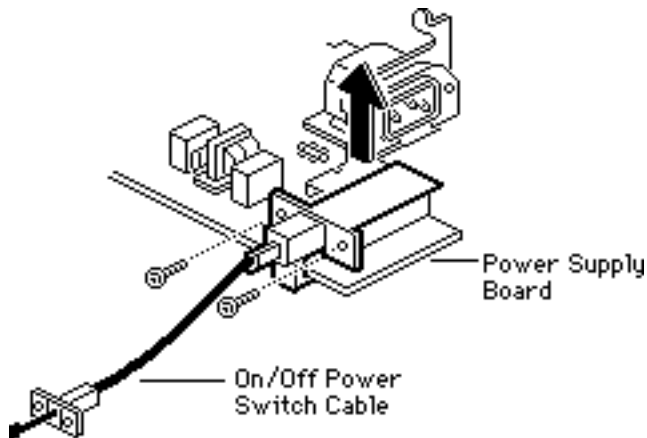

Replacement Caution: Leave the cable along the side until you replace the mechanical assembly. Make sure the on/off switch is in the correct position; otherwise the switch can jam under the mechanical assembly and will not function correctly.





Sub PCB Interface Board

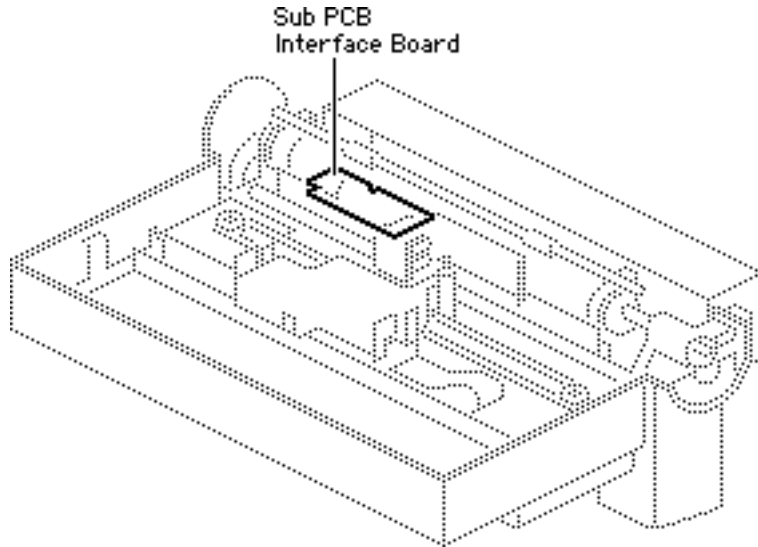

Before you begin, remove the following:

- Covers
- Mechanical assembly

Caution: Review the ESD precautions in Bulletins/ Safety.





- 1 Remove the screw.

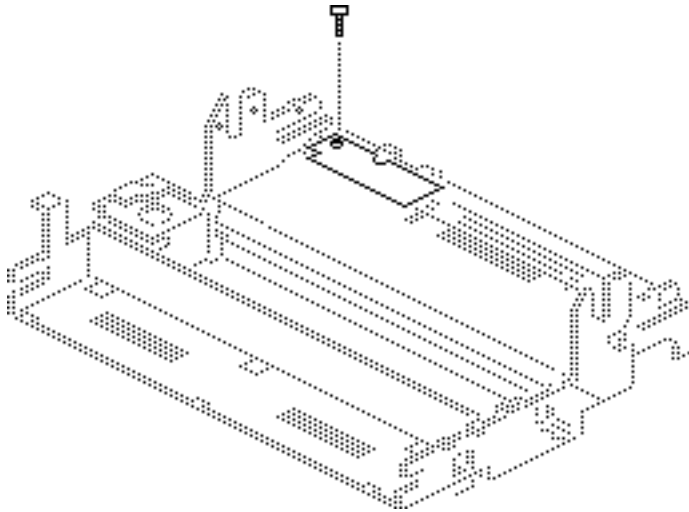



- 2 Squeeze the two standoffs and push down.

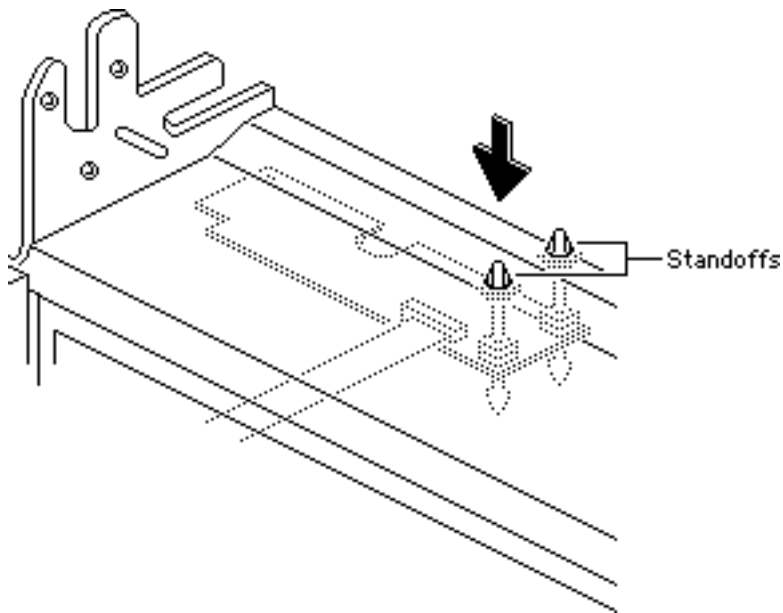

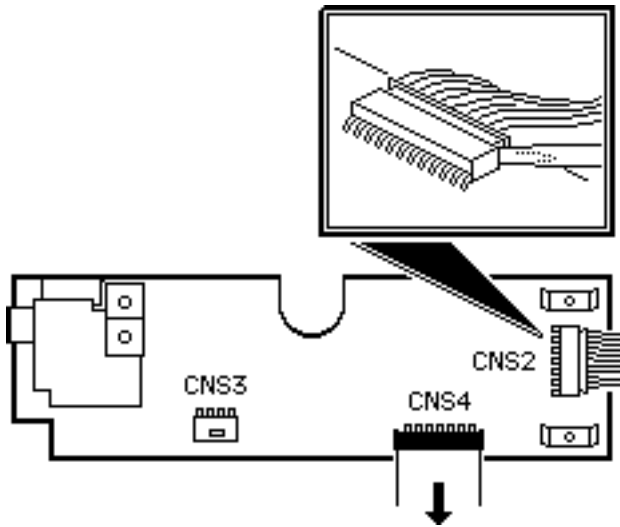

- 3 Pry on one side and then the other side of connector CNS2, and remove the connector from the cut-sheet feeder.
- 4 Remove the three-wire connector CNS3 from the paper-out sensor.
- 5 Gently pull out the 18-pin connector CNS4 and remove the ribbon cable.





Replacement Note: If you are replacing the ribbon cable, disconnect the other end of the ribbon cable from connector CN4 on the main board.

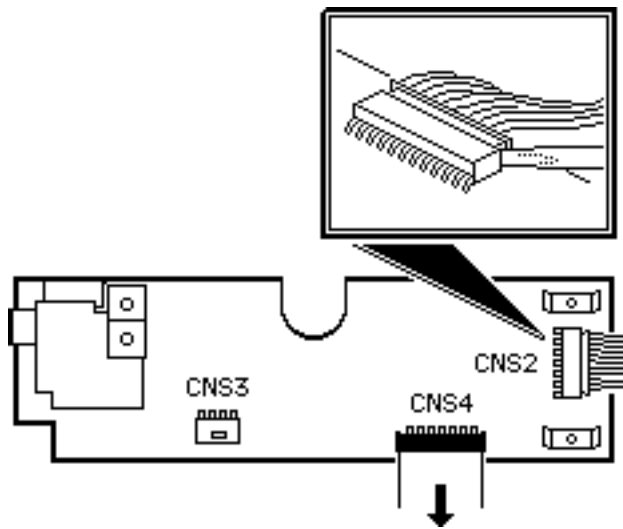



Line Feed Motor

Before you begin, remove the following:

- Covers
- Mechanical assembly

Caution: Review the ESD precautions in Bulletins/Safety.

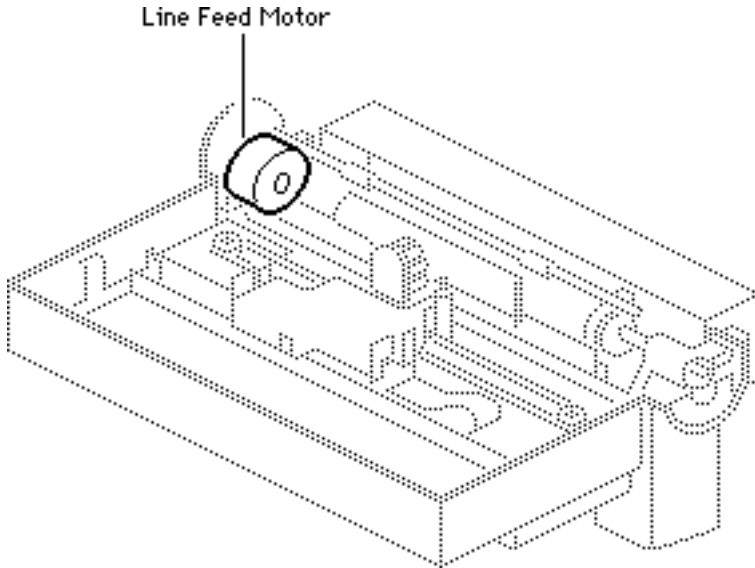

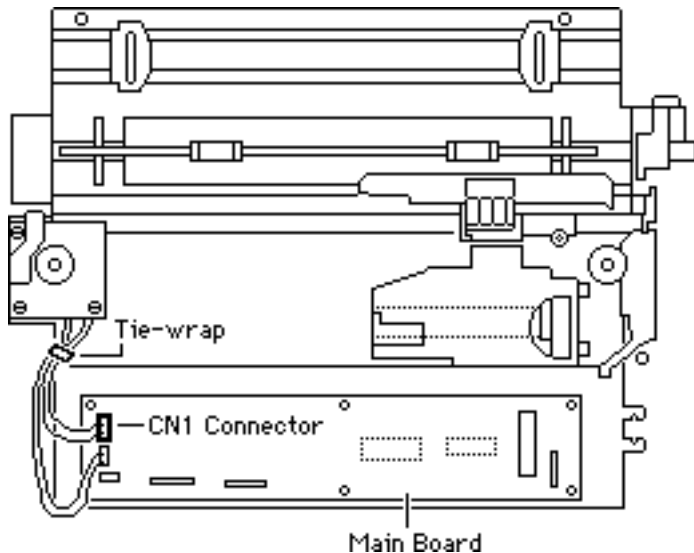

- 1 Disconnect connector CN1 from the main board.
- 2 Cut the tie-wrap from the wires to the main board.





- 3 Remove the two screws and gently pull the motor off the mechanical assembly.

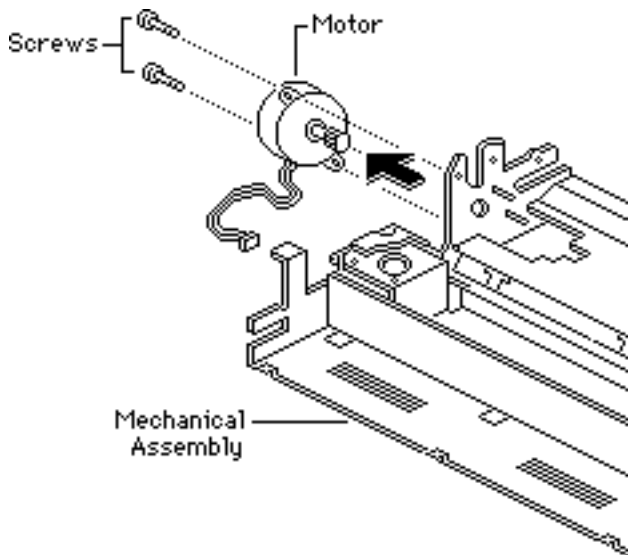



Carrier Assembly

Before you begin, remove the following:

- Mechanical assembly
- Print head
- Paper guide
- Drive belt

Caution: Review the ESD precautions in Bulletins/Safety.

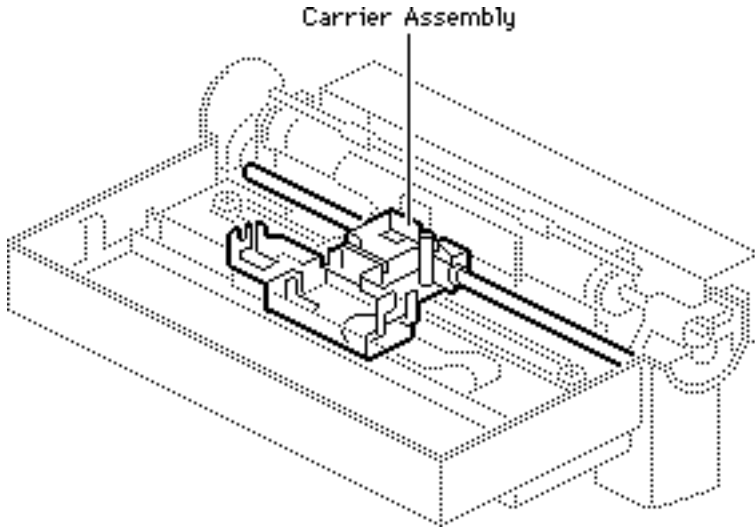



- 1 Unhook the ribbon wire from both sides of the frame.

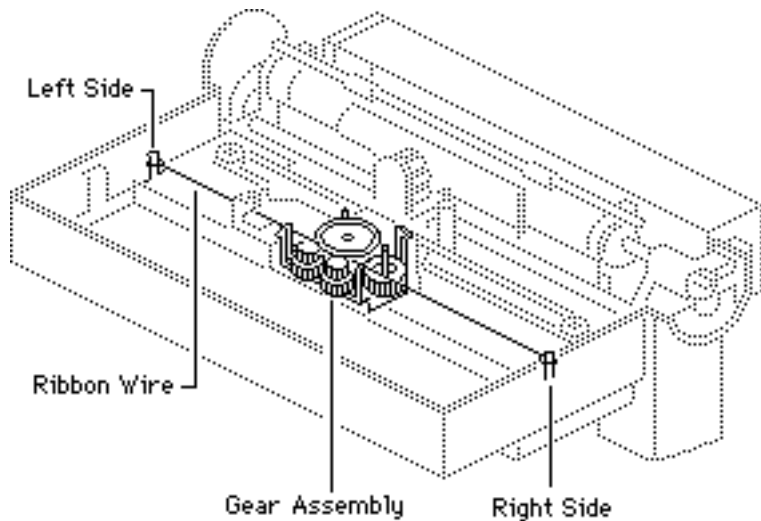

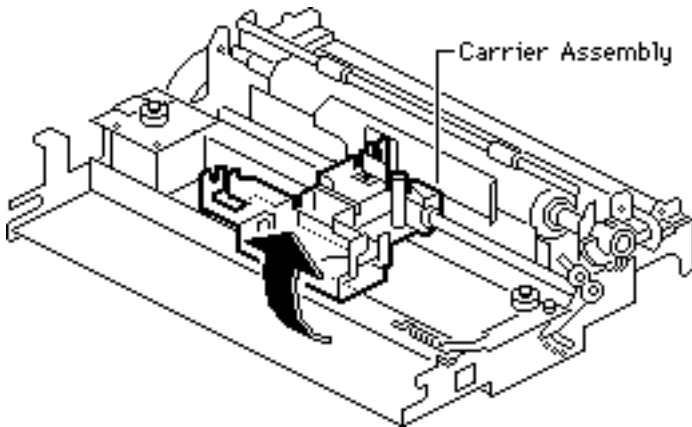

- 2 Move the carrier assembly to the right so that the right edge of the carrier housing is lined up with the edge of the main board or the right edge of the platen.
- 3 Lift the front edge of the carrier assembly and remove the carrier from the metal rail guide.





- 4 Using needlenose pliers, pry the metal finger toward the front of the printer.

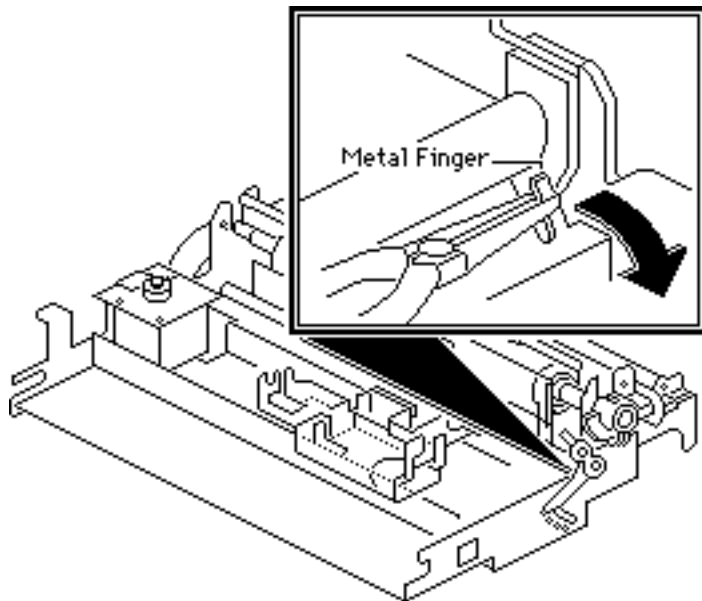

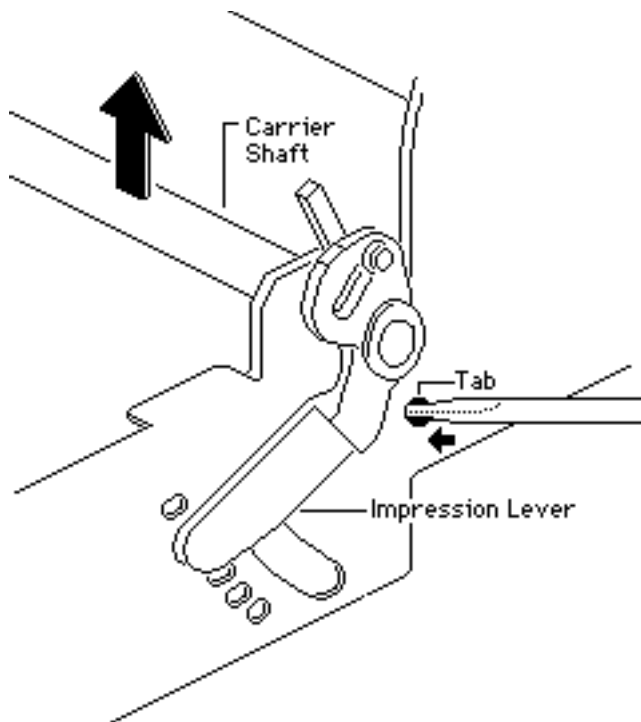

Carrier Shaft

- 1 **Note:** It might be easier if you remove the line feed motor before you remove the carrier shaft; however, removing the motor is not necessary.

Using a small flat-blade screwdriver, push the tab backward and lift the right side of the carrier shaft free.



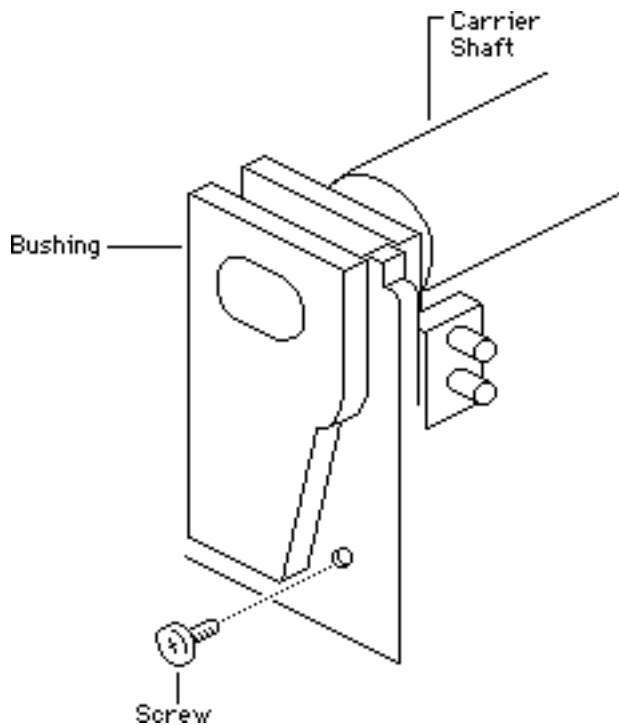

- 2 Remove the screw from the motor side.



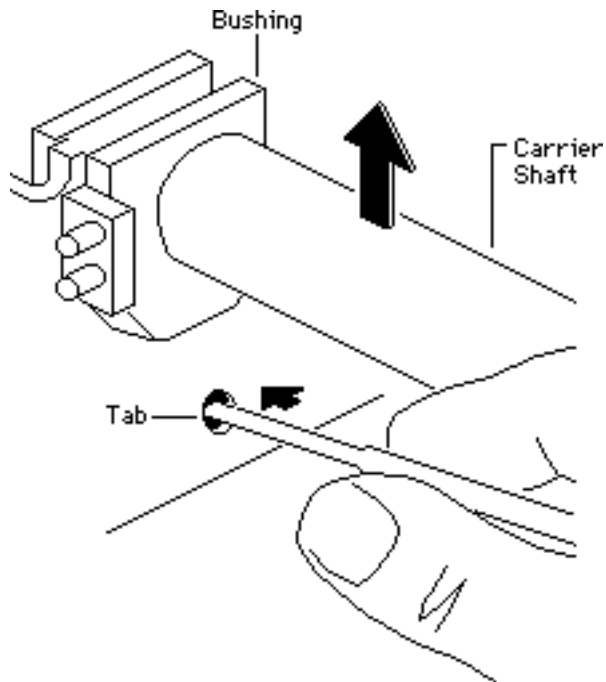

- 3 Using a small flat-blade screwdriver, push the tab backward and lift the left side of the carrier shaft free.





- 4 Remove the carrier cam from the left side of the carrier shaft.

Replacement Note:

Install the carrier cam on the left side of the carrier shaft so that the flat section of the cam faces the front of the printer. The wrong position produces uneven printing.

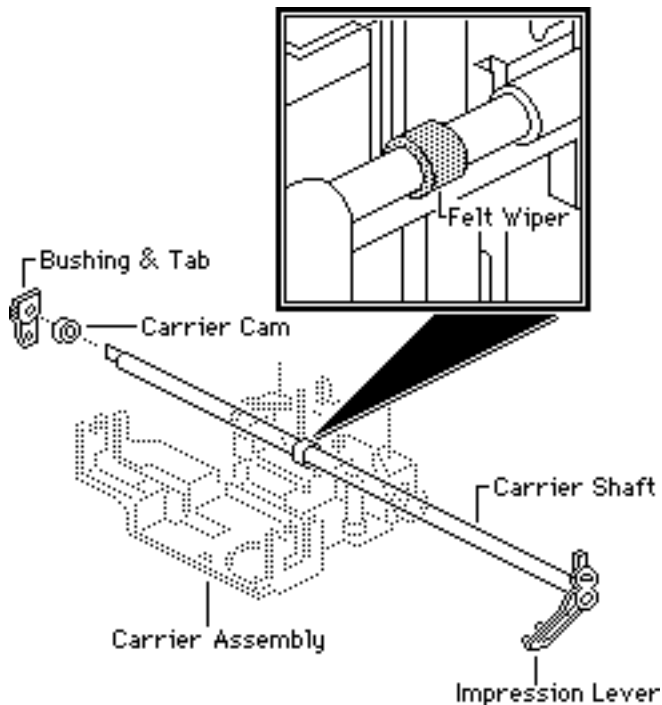



- 5 Slide the carrier shaft free of the carrier assembly. Remove the shaft and the felt wiper.

Replacement Note: In order for the carrier assembly to work properly, the alignment of the carrier shaft is critical.

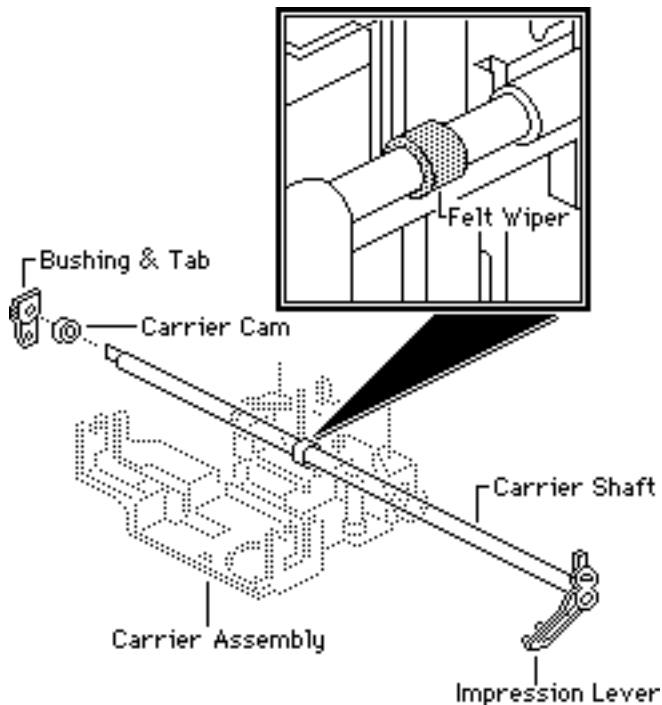



Paper Deflector

Unhook the three springs that hold the paper deflector to the frame. Remove the deflector.

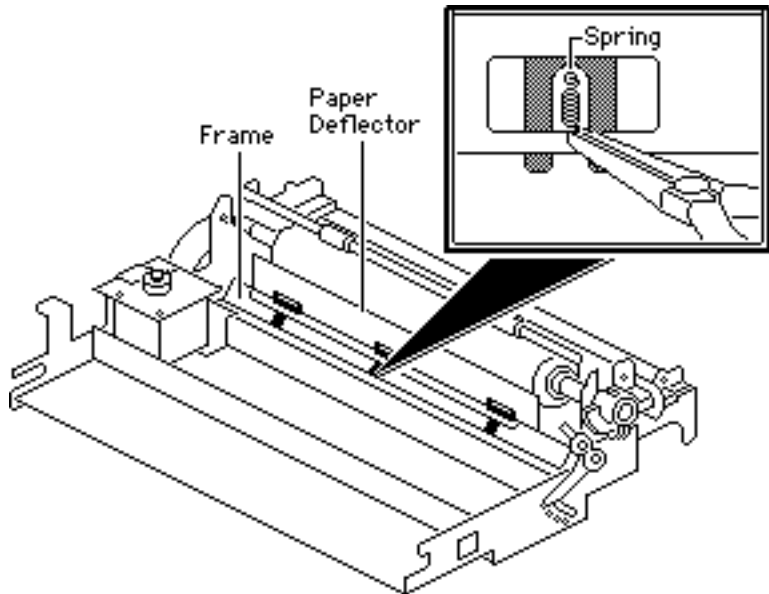



Print Head Board

Before you begin, remove the carrier assembly.

Caution: Review the ESD precautions in Bulletins/ Safety.

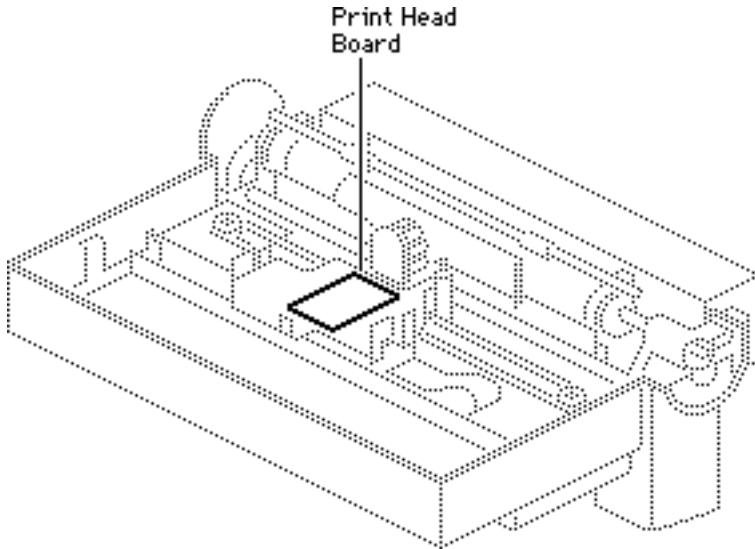



- 1 Remove the shaft and turn over the carrier.
- 2 Remove the two screws that hold the print head board.

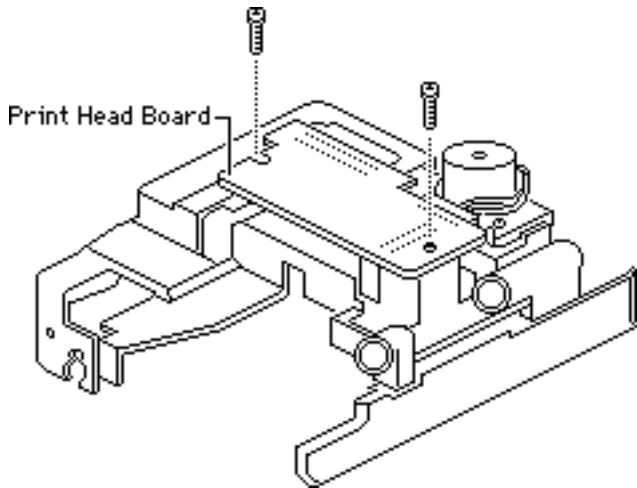

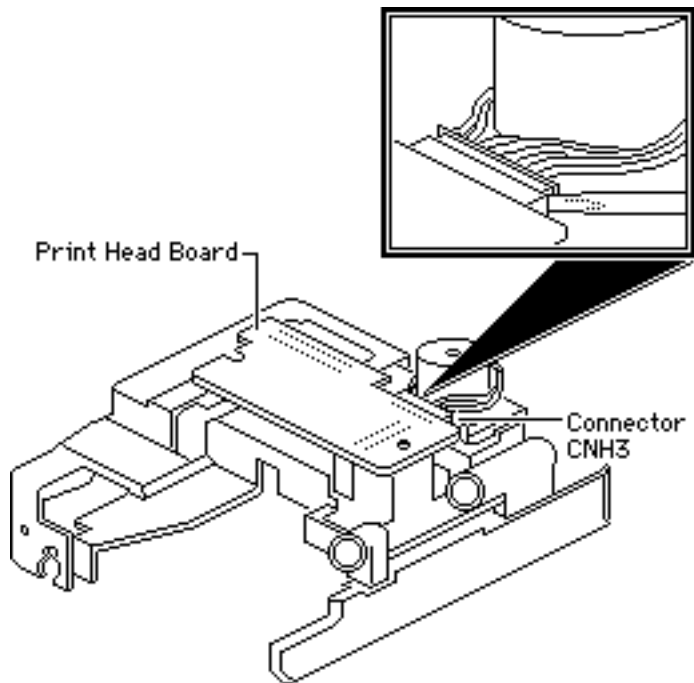

- 3 To disconnect the board, gently lift the side of the board and pry it from ribbon motor connector CNH3. Remove the board.





Shift Gear/ Transfer Gears

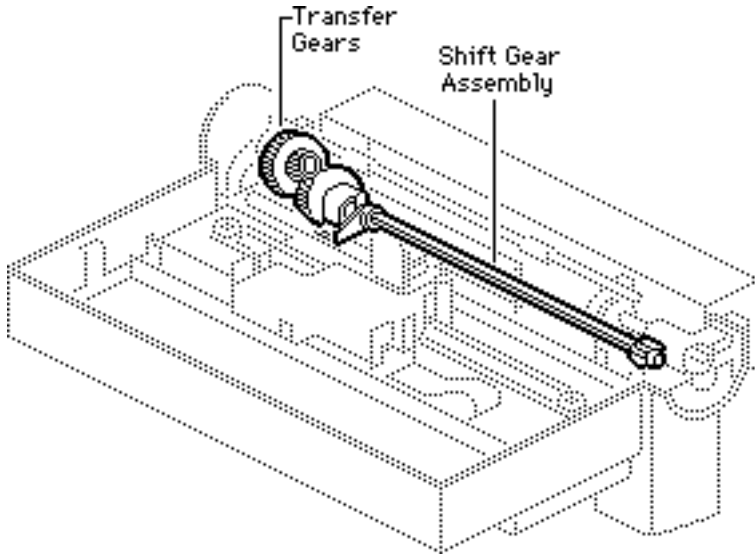

Before you begin, remove the following:

- Mechanical assembly
- Paper bail assembly
- Tractor feed
- Pinch roller assembly

Caution: Review the ESD precautions in Bulletins/Safety.





Shift Gear Assembly

Remove the one screw and lift the shift gear assembly from the frame.

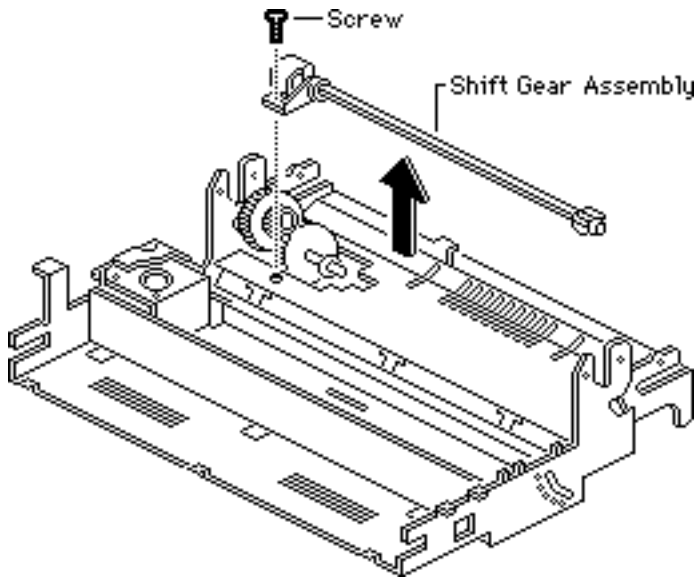

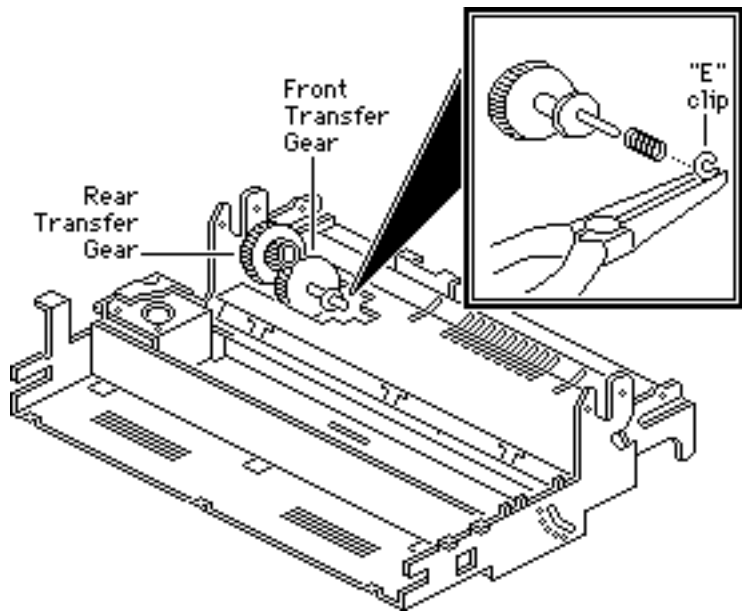

Transfer Gears

- 1 **Note:** Use care in removing the "E" clip. The clip can fly off.

Using a small screwdriver, a hook, or small needlenose pliers, remove the "E" clip from the large gear and slide the front transfer gear out.



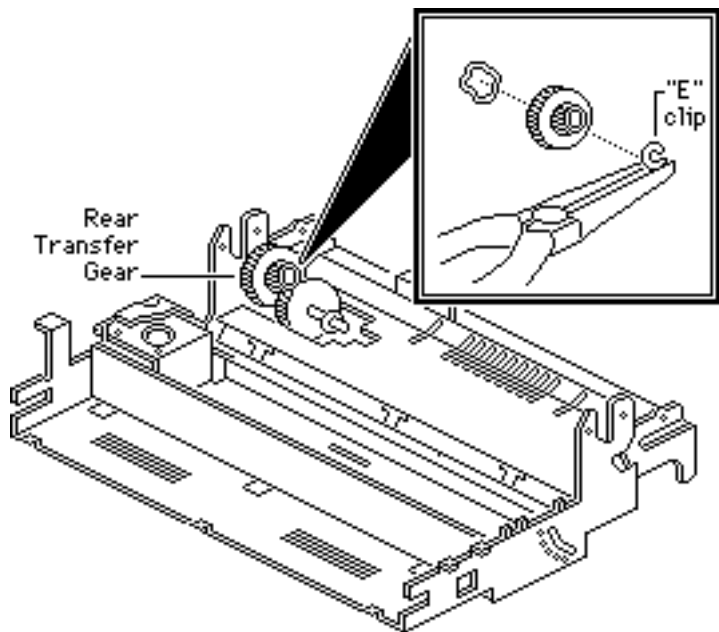

- 2 Using a small screwdriver, a hook, or small needlenose pliers, remove the "E" clip from the smaller gear and slide the rear transfer gear off.





Paper Bail Assembly

Before you begin, remove the mechanical assembly.

Caution: Review the ESD precautions in Bulletins/ Safety.

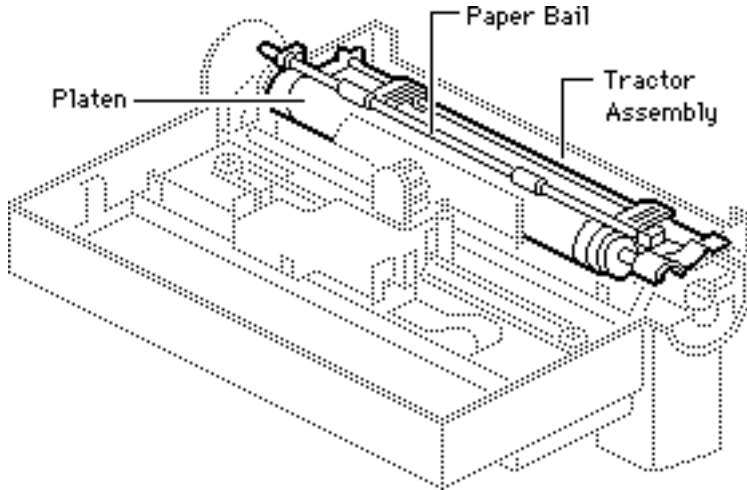



Paper Bail

- 1 Using a small screwdriver, pry out the paper release lever.
- 2 Using small needlenose pliers, unhook the two springs on each side of the platen.

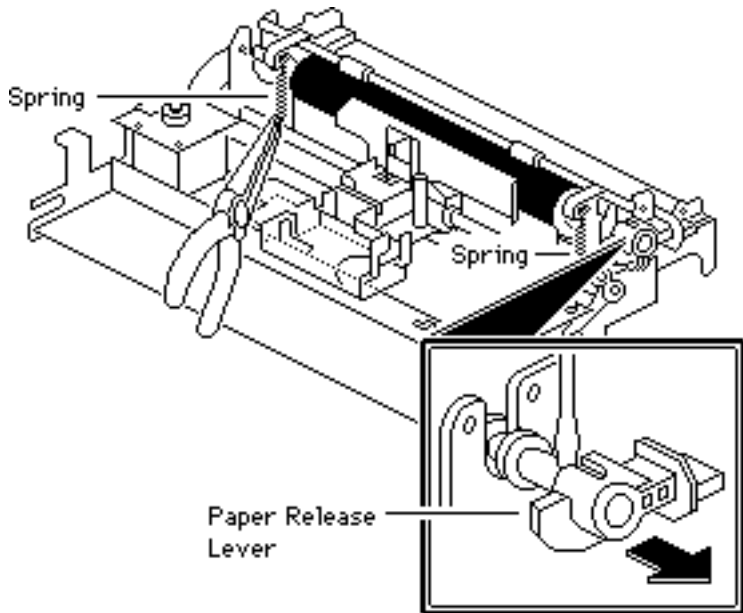



- 3 Unscrew and remove the right-side bracket.
- 4 Unscrew and remove the left-side bracket.

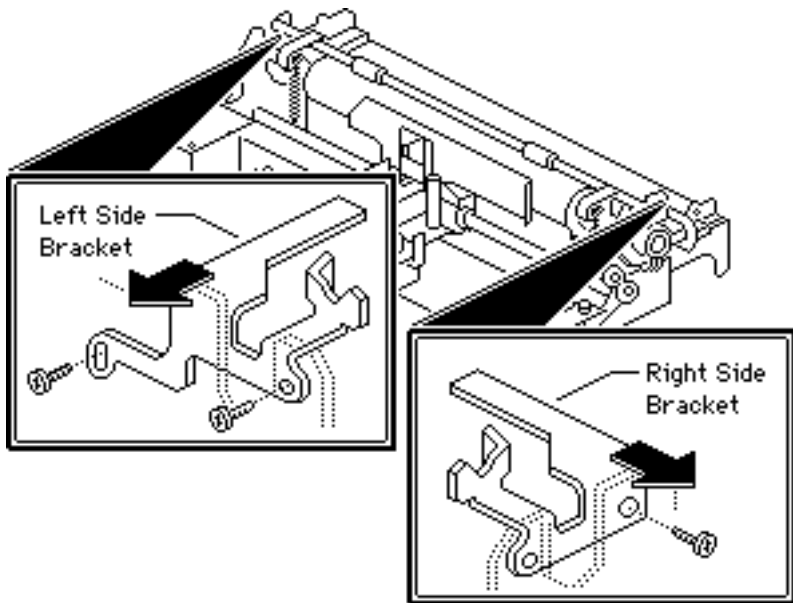



- 5 Lift the paper bail, rotate it to the back position, and gently push down on the bail so it snaps off the standoffs.

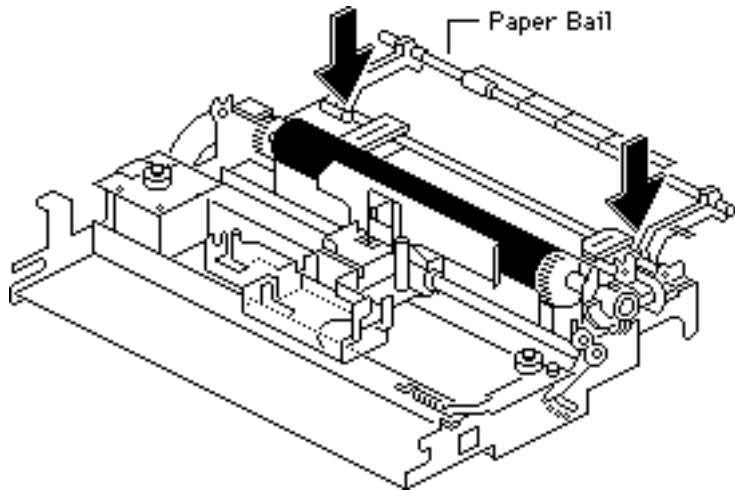



Platen Roller and Gears

- 1 Lift out the platen.

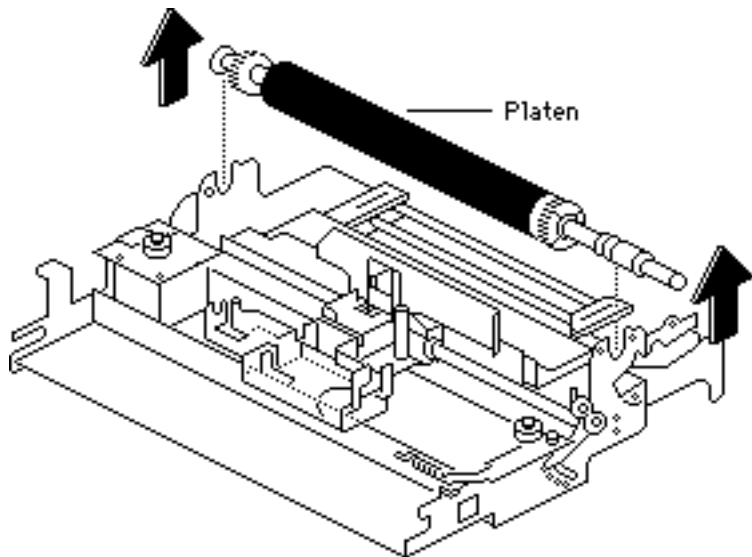



- 2 On the left side, slide off the black plastic bushing and remove the gear.

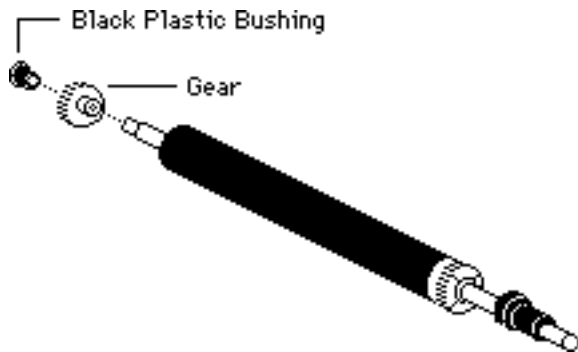



- 3 On the right side, remove the black plastic bushing and the tension washer.
- 4 Using a pin punch, gently tap out the pin and remove the right-side gear.

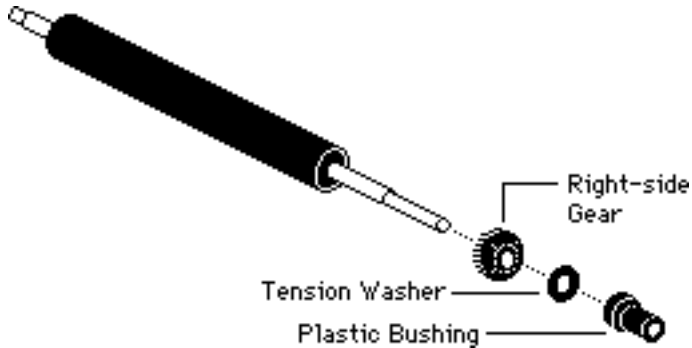

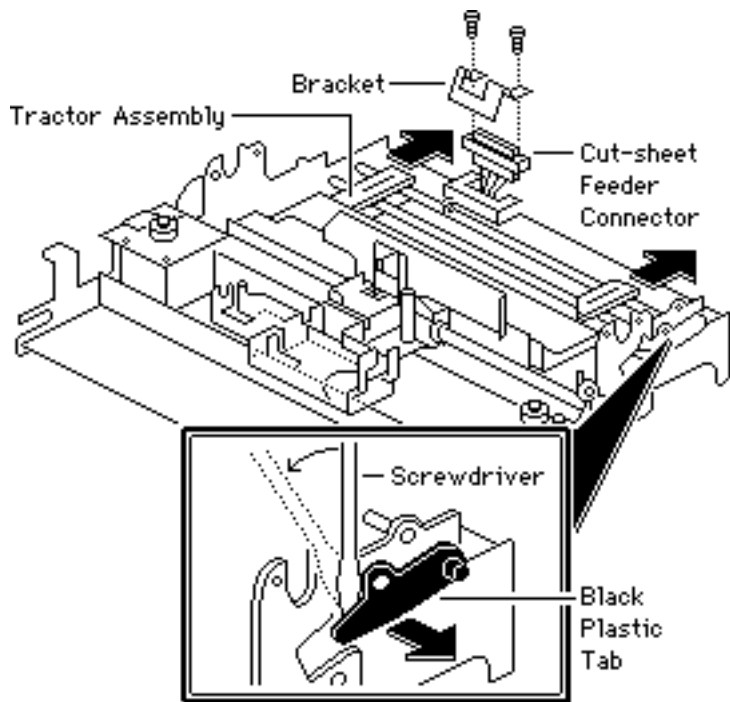

Tractor Assembly

- 1 Remove the two screws on the cut-sheet feeder connector and brackets.
- 2 Using a small screwdriver, pry back the black plastic tab inside the hole on the right-rear side of the frame and gently pull back the tractor assembly 1/4 inch.



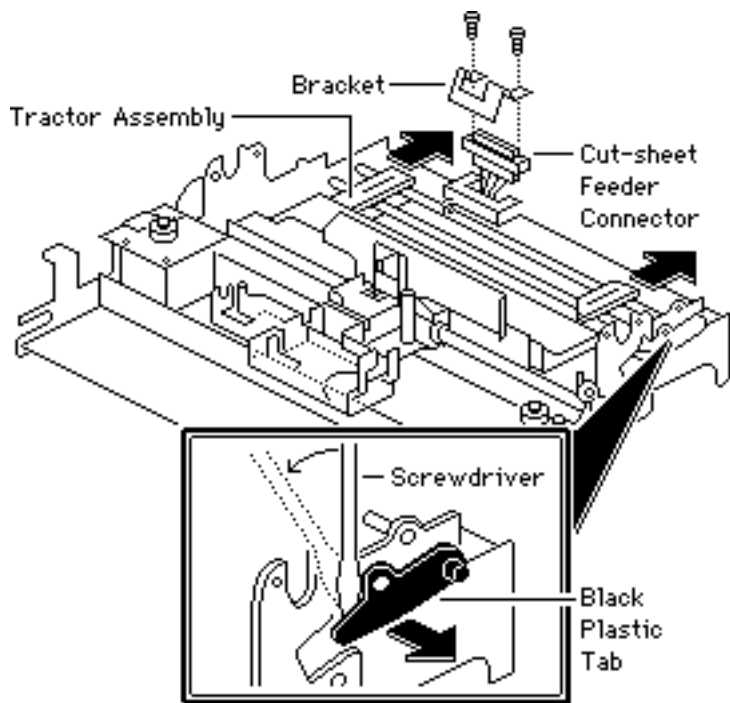

- 3 Repeat for the left side and pull the tractor assembly straight out of the rear of the mechanical assembly.





Pinch Roller Assembly

- 1 Remove the two screws on the back of the pinch roller assembly.

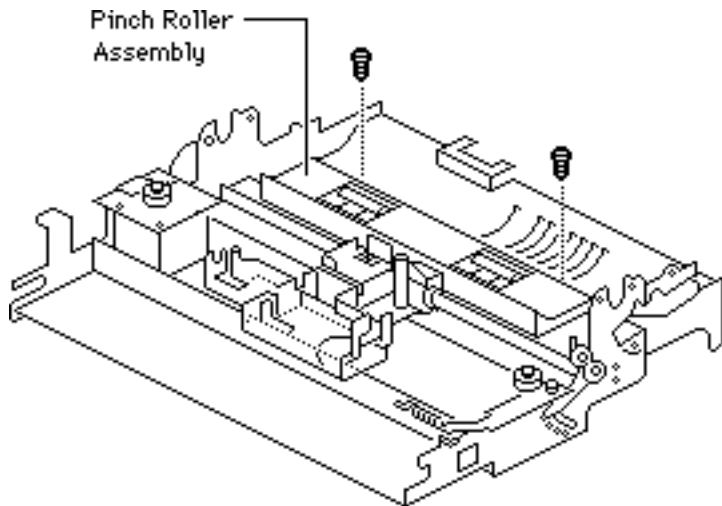

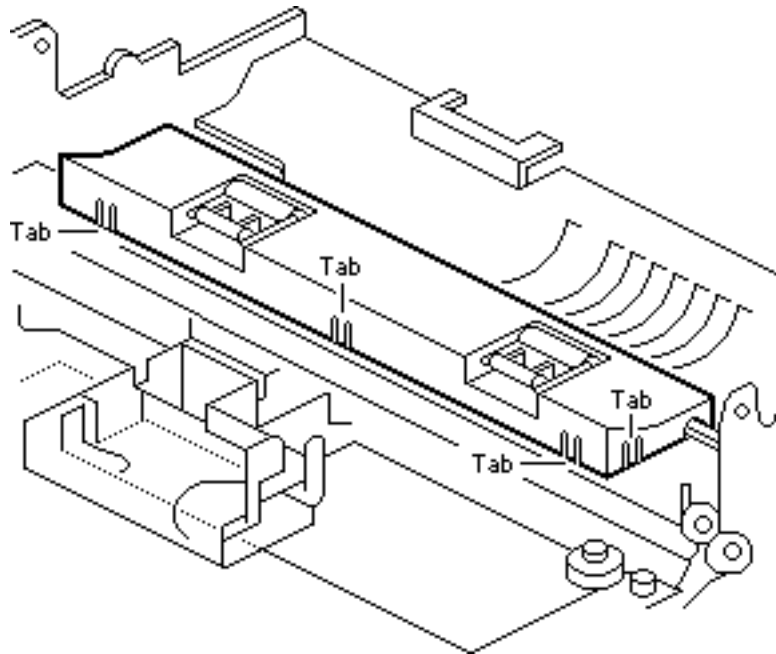

- 2 Using a flat-blade screwdriver, gently pry the roller assembly free from the five tabs.



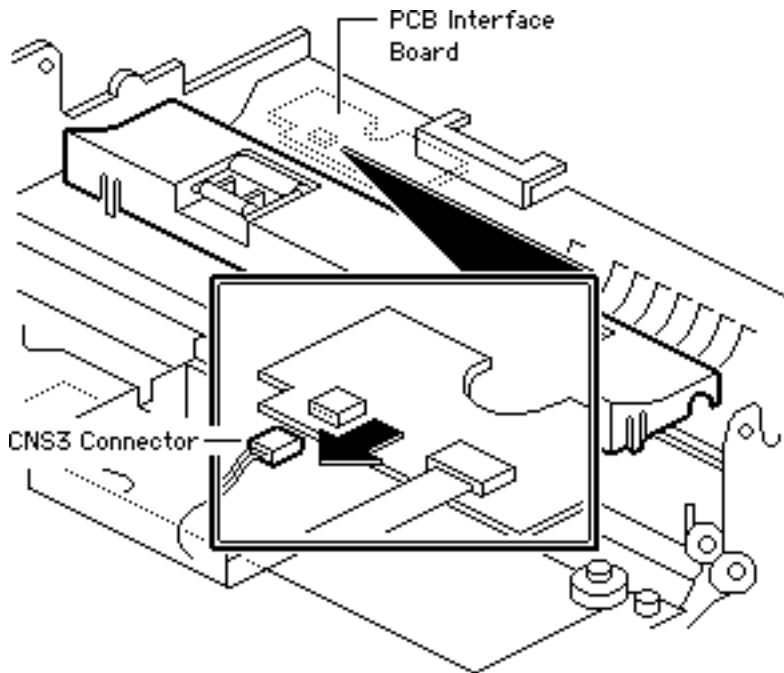

- 3 Pull up the front section of the pinch roller assembly until the assembly is loose and remove the connector CNS3 from the sub PCB interface board.



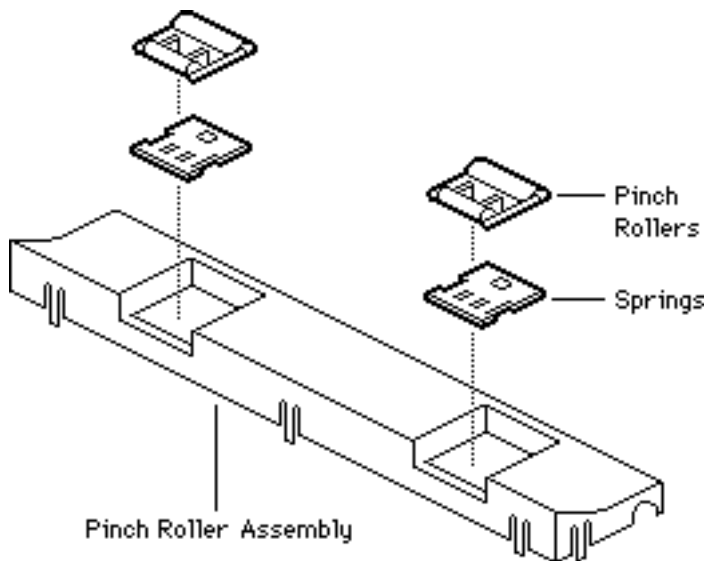

- 4 Lift off the two pinch rollers and pinch roller springs.
- 5 Push up on the small roller from underneath.



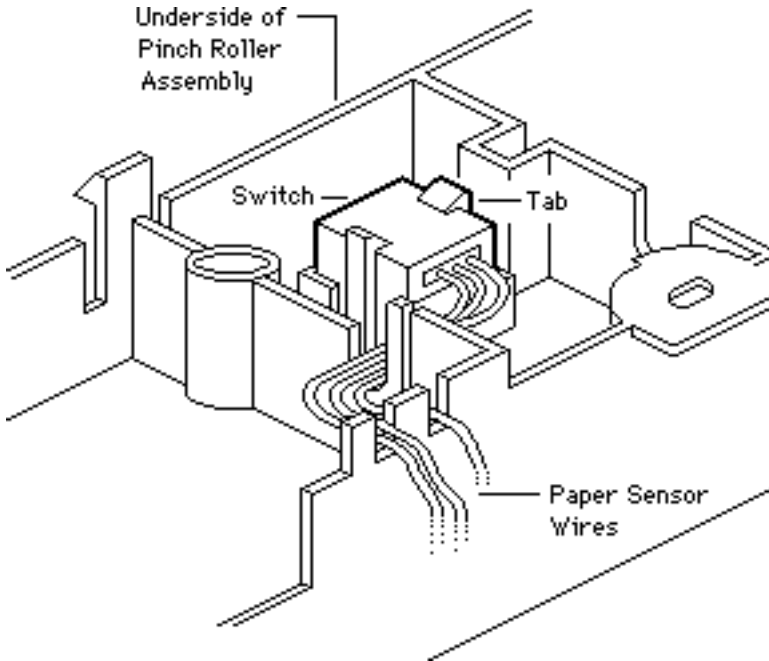

Paper -Out Sensor

- 1 Turn over the assembly and gently lift the three paper sensor wires from the cut-outs on the roller housing.
- 2 Using a small flat-blade screwdriver, gently pry the tabs that retain the switch and at the same time lift the switch.





Upgrades

ImageWriter II/L





Option Board

Before you begin, remove the top cover.

Caution: Review the ESD precautions in Bulletins/ Safety.

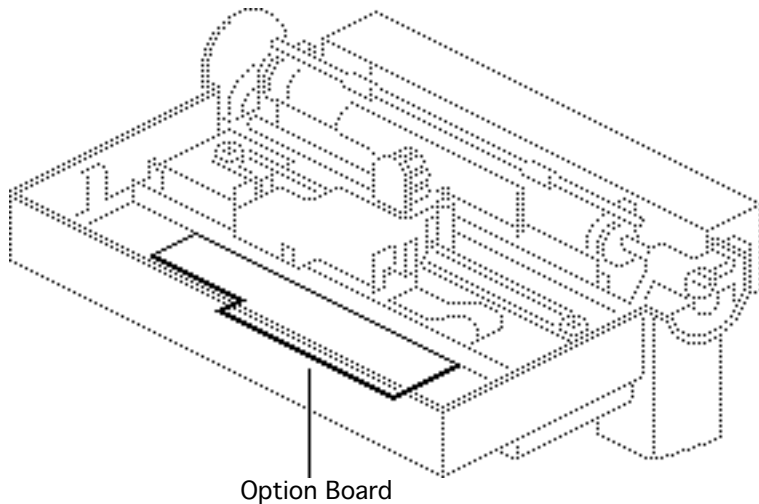

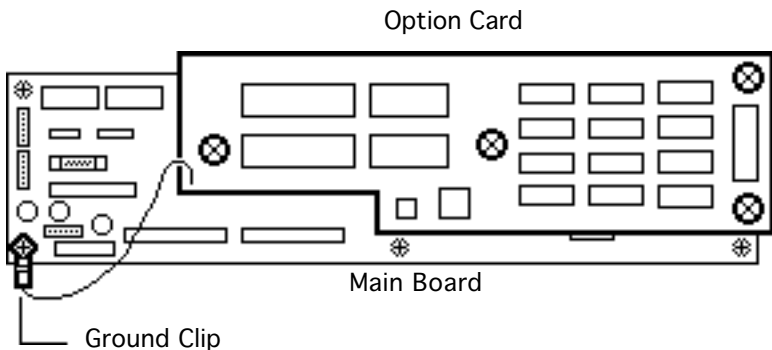

- 1 Remove the ground clip from the main board.
- 2 **Caution:** Remove the option board carefully. Do not damage the main board.

Using needlenose pliers, squeeze the four retainers and lift out the option card. Disconnect the card from connector CN6 on the main board.





Additional Procedures

ImageWriter II/L





Main Logic Board Fuse

Before you begin, remove the covers.

Caution: Review the ESD precautions in Bulletins/ Safety.

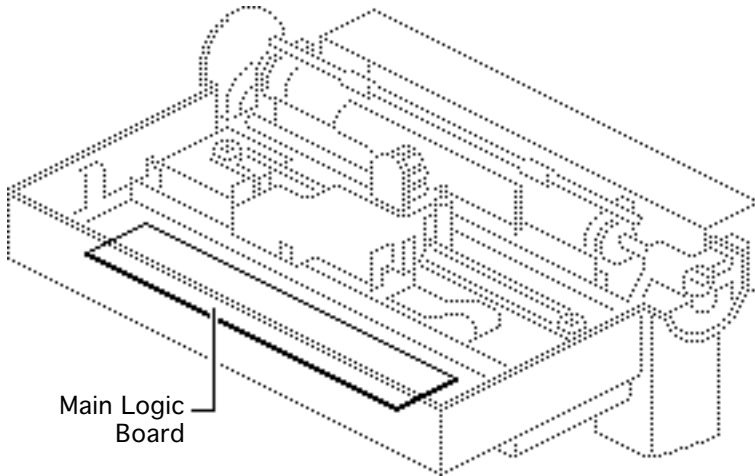

Main Logic Board





- 1 Using a fuse puller, remove fuse FU1 from the main board.
- 2 Replace blown fuses.

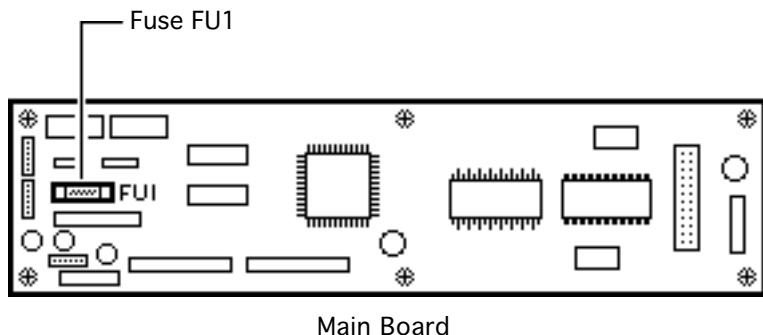



Power Supply Fuses

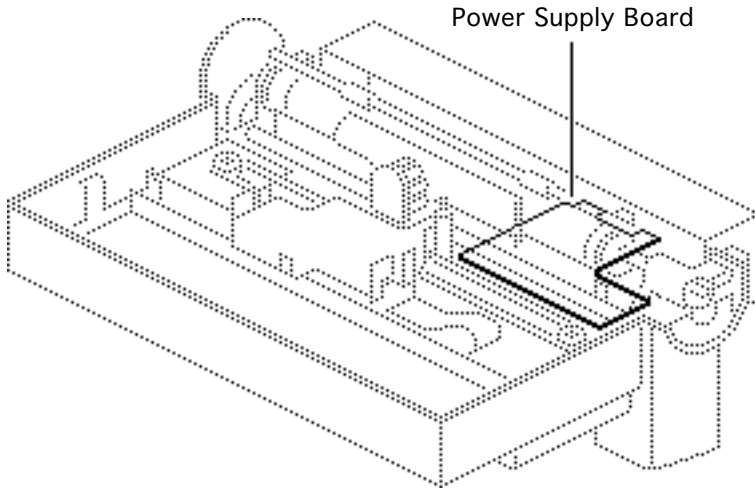

Before you begin, remove the following:

- Covers
- Mechanical assembly

Caution: Review the ESD precautions in Bulletins/ Safety.



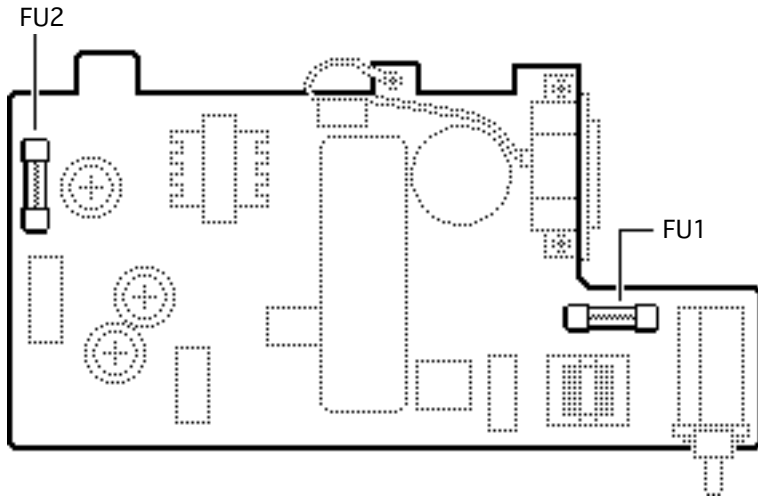

- 1 Using a fuse puller, remove fuse FU1 and FU2 from the power supply board.
- 2 Replace blown fuses.





Shims

Before you begin, remove the covers.

Caution: Review the ESD precautions in Bulletins/ Safety.

Note: This procedure covers the gap check, and the installation and removal of the shims.

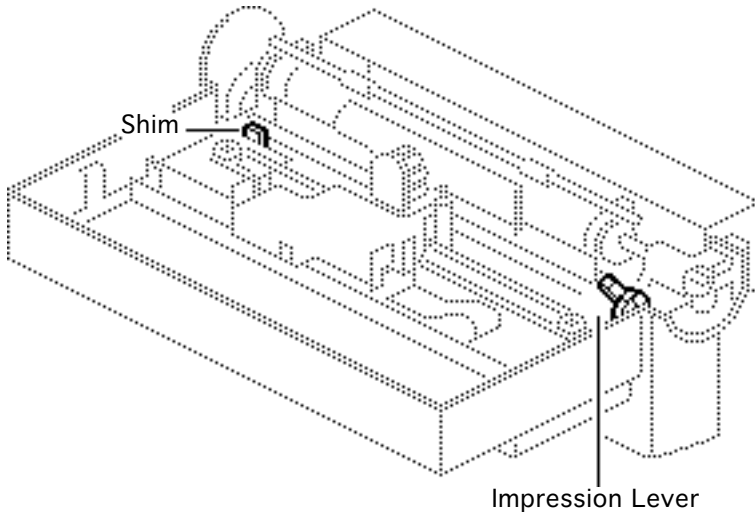

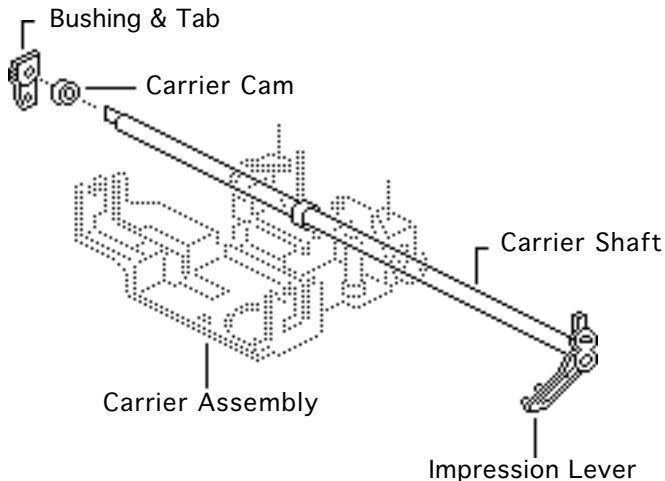

Note: Before performing the following procedures on shims, check the cam washer on the left side of the carrier shaft to be sure the washer is in position. The flat part of the hole in the cam should face the front of the printer when you place the cam on the carrier shaft. Refer to “Carrier Assembly” in the Take Apart chapter.



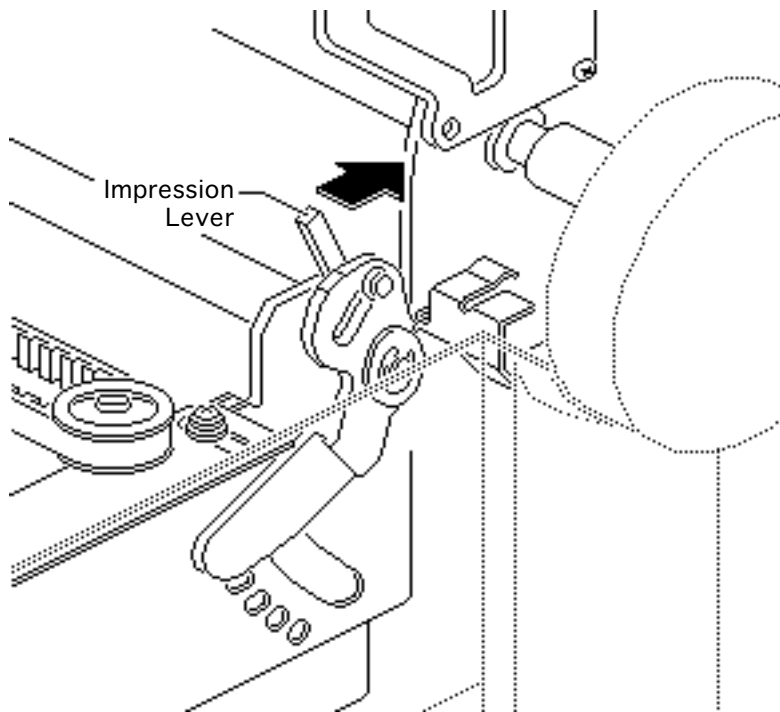

Gap Check

- 1 Pull the impression lever so that the dot head is in the closest position to the platen.



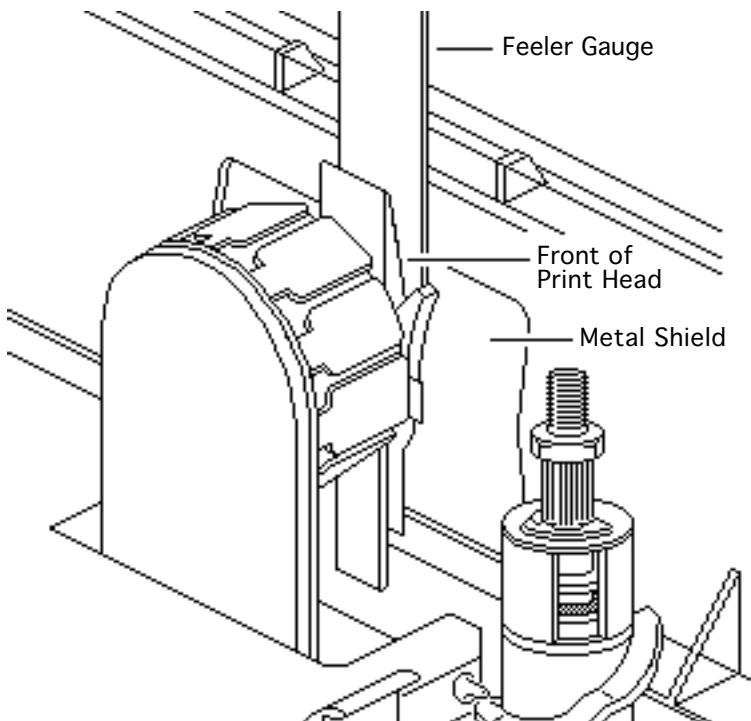

Note: The recommended gap for the following readings should be .013 inches (0.33 mm) \pm .002 inches (0.05 mm).

- 2 Push the carrier to the far right. Using a feeler gauge, measure the gap between the front of the print head and the metal shield on the paper guide.
- 3 Record the measurement.



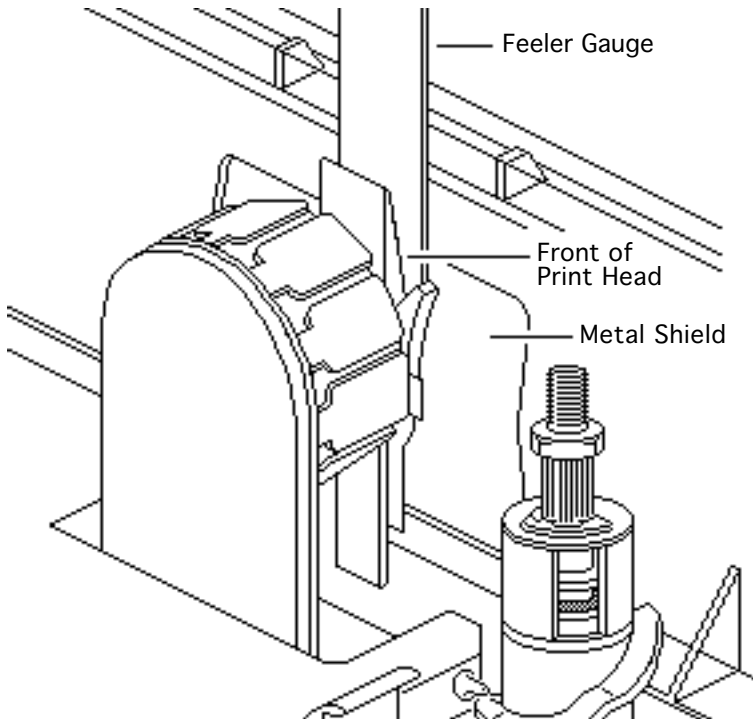

- 4 Push the carrier to the far left. Using a feeler gauge, measure the gap between the front of the print head and the metal shield on the paper guide.
- 5 Subtract the right gap clearance from the left gap clearance.
 - If the difference is a positive number, install a shim.
 - If the difference is a negative number, remove a shim.



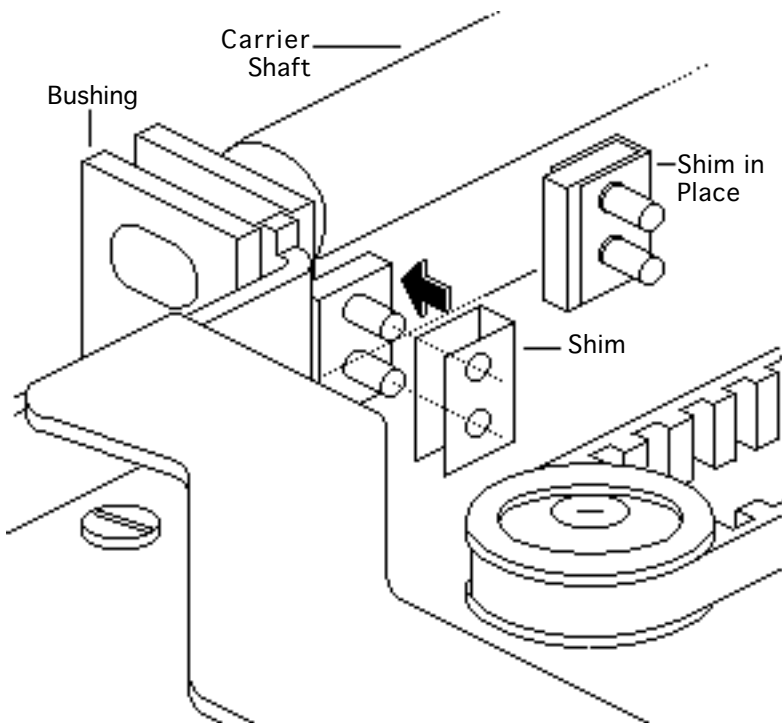

Install Shim

- 1 Select a shim that comes closest to the difference calculated.
 - 0.002 inch (0.05 mm)
 - 0.004 inch (0.1 mm)
 - 0.008 inch (0.2 mm)
- 2 Push the carrier shaft toward the rear of the printer. Using needlenose pliers, insert the two protruding tabs into the holes on the shim and slide the shim into position.



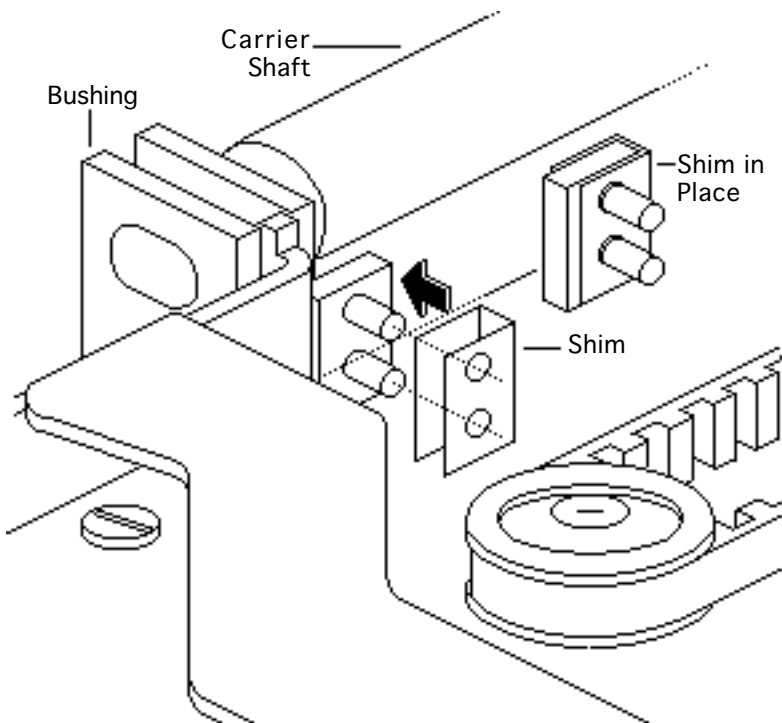

- 3 Release the carrier shaft.
- 4 Verify that the gap is correct.



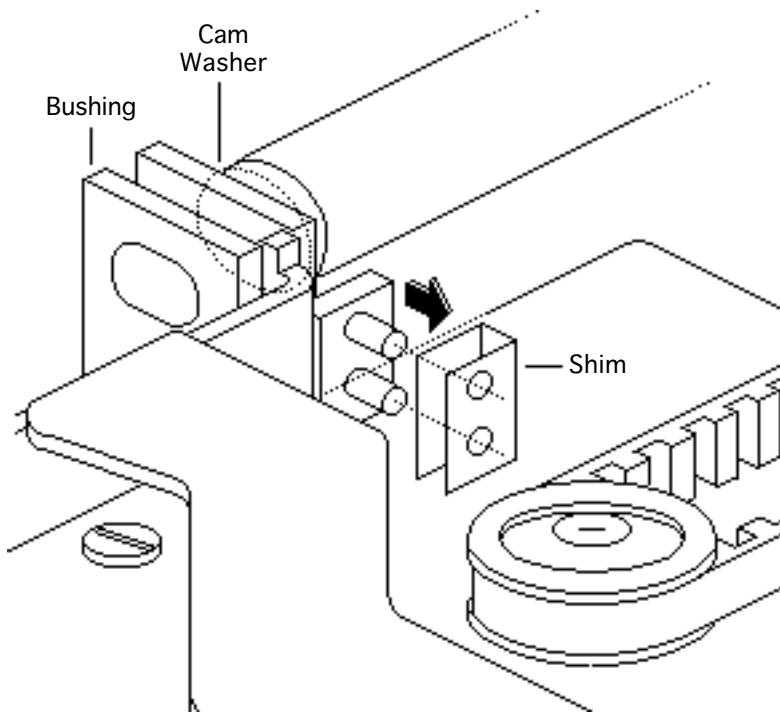

Remove Shim

- 1 Using needlenose pliers, remove the shim from the carrier shaft.
- 2 If there is no shim installed, make sure the cam washer on the left side is in the correct position.
- 3 Verify that the gap is correct.



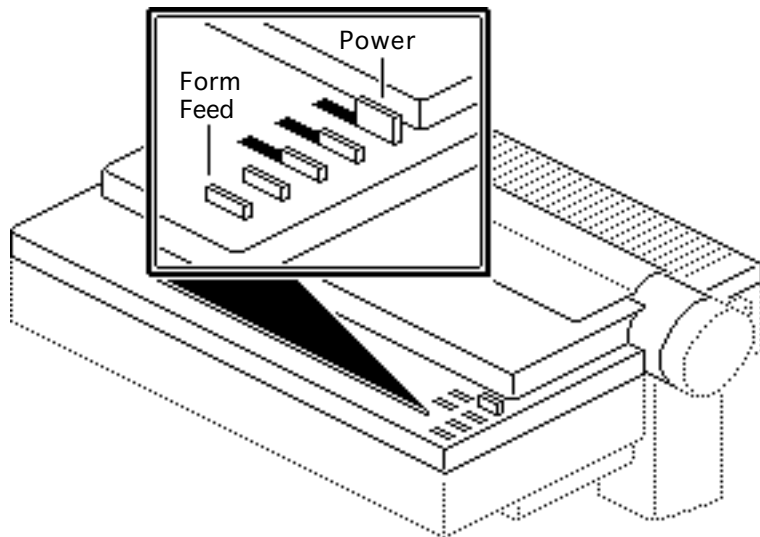

Self-Test

No preliminary steps are required before you begin this procedure.

- 1 Make sure the power is off. Load the paper.
- 2 Press and hold down the form-feed switch while you switch on the power. Release both switches.





```
ABCDEFGHIJKLMN OPQRSTUVWXYZ1234567890!@#$%^&* _+
ABCDEFGHIJKLMN OPQRSTUVWXYZ1234567890!@#$%^&* _+
ABCDEFGHIJKLMN OPQRSTUVWXYZ1234567890!@#$%^&* _+
ABCDEFGHIJKLMN OPQRSTUVWXYZ1234567890!@#$%^&* _+
```

Note: If you use a color ribbon, the test printout will alternate the colors of each line.

The first part of the print shows the ROM revision number, the DIP switch settings, and whether either option card is installed.

Next the printout shows lines of characters. Each line contains the letters of the alphabet, the numbers 0 through 9, and a series of special characters.



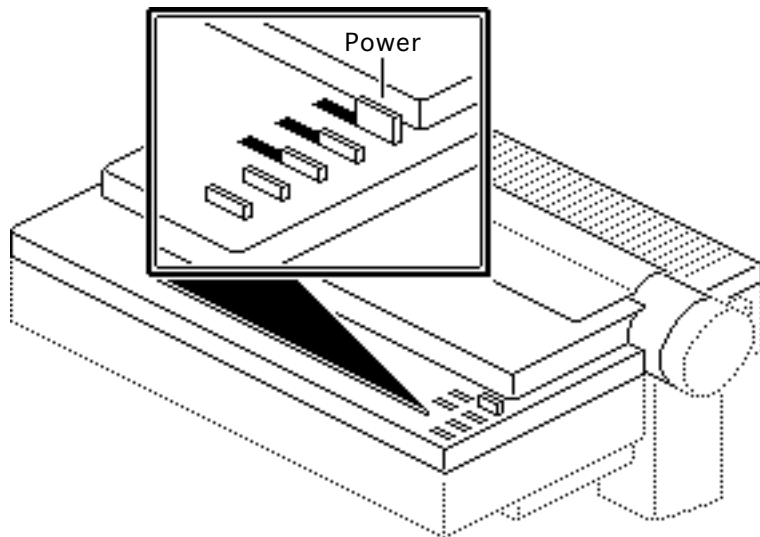

- 3 To end the test, switch off the power.

Note: If you accidentally depress the select button during power-up, the next data sent to the ImageWriter will be a hexadecimal dump. If you see such a dump, switch the ImageWriter off and then back on. The printer will power up in the proper mode.





Carrier Shaft Maintenance

Carrier Shaft

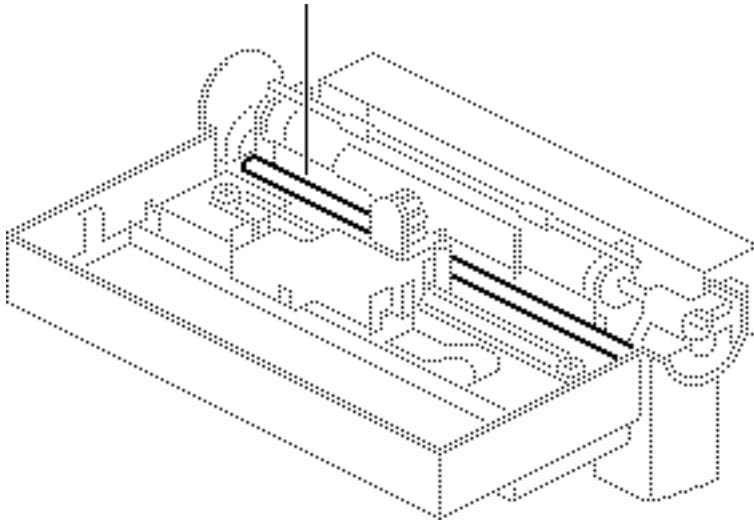

Before you begin, remove the following:

- Covers
- Carrier assembly

Caution: Review the ESD precautions in Bulletins/ Safety.



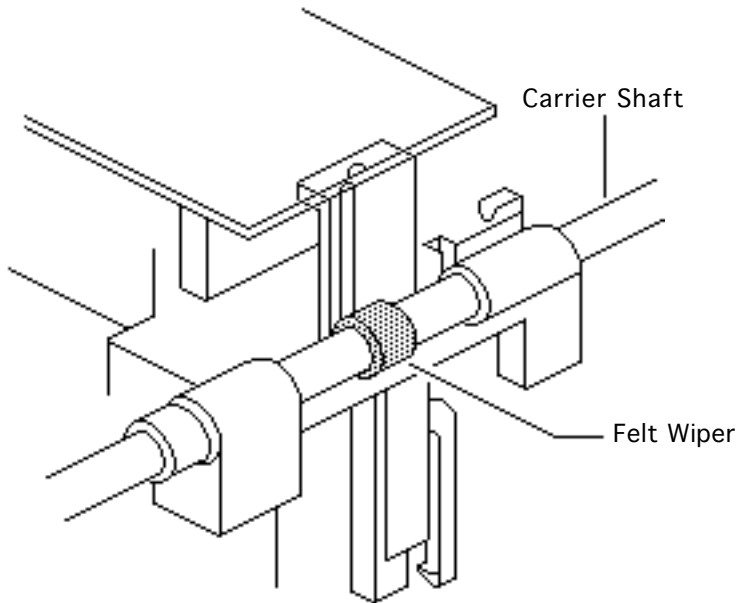

- 1 Using gauze or cotton, wipe off the carrier shaft.
- 2 Apply four drops of light lubricating oil to each of the felt wipers.





Dot Head Maintenance

Before you begin, remove the following:

- Covers
- Print head

Caution: Review the ESD precautions in Bulletins/ Safety.

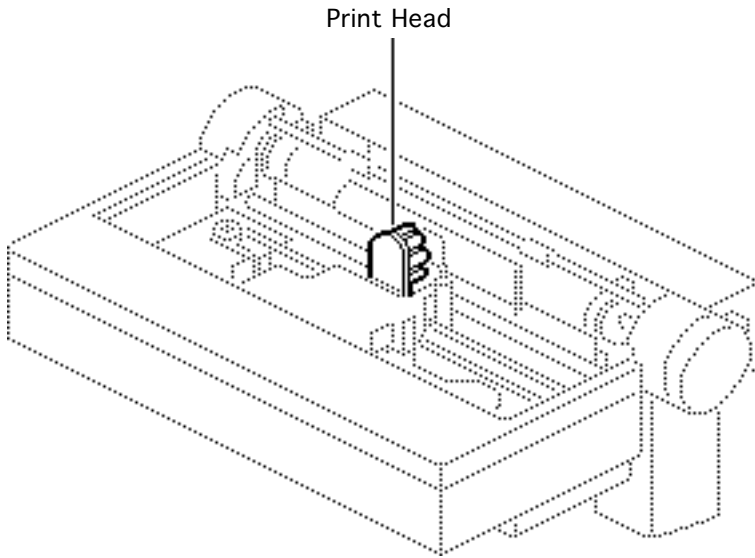

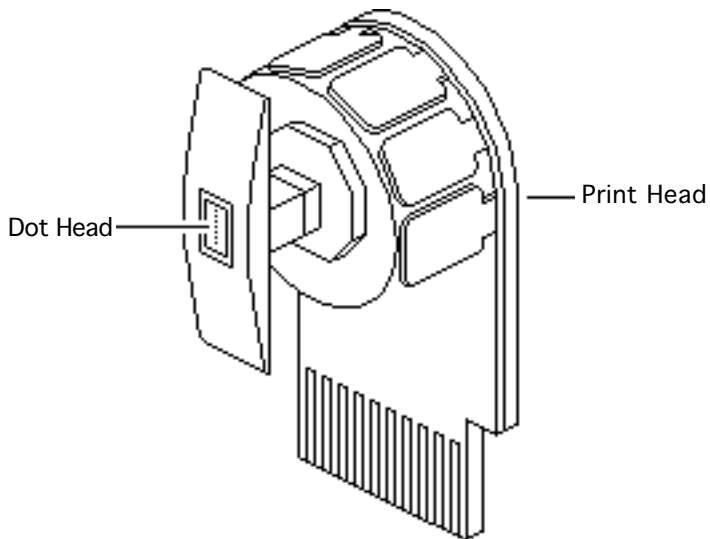

- 1 Using a lint-free cloth and isopropyl alcohol, clean the dot head.
- 2 Perform the self-test.





Adjustments

ImageWriter II/L





Ribbon Cam

No preliminary steps are required before you begin this procedure.

Caution: Review the ESD precautions in Bulletins/ Safety.

Note: Perform the ribbon cam adjustment when the color print function fails, when you replace the color ribbon, when dots are missing, or when no printout appears when you use a black ribbon.

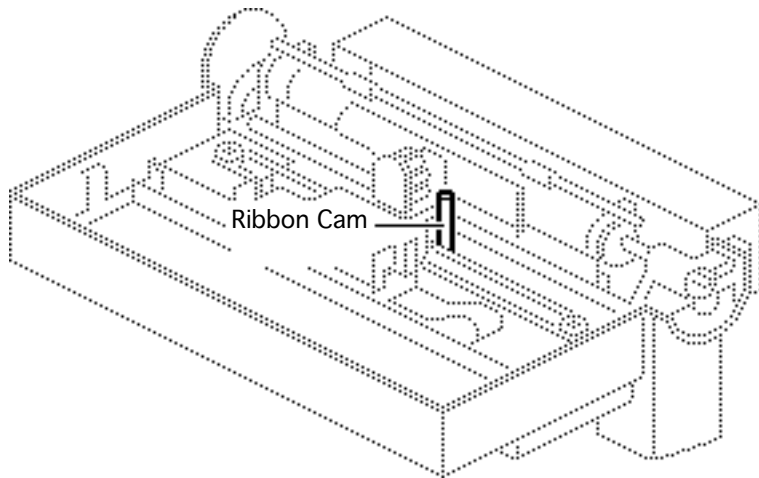



- 1 Run the self-test. See Additional Procedures.

ABCDEFGHIJKLMN O PQRSTU VWXYZ1234567890!@#\$%^&* _+
ABCDEFGHIJKLMN O PQRSTU VWXYZ1234567890!@#\$%^&* _+
ABCDEFGHIJKLMN O PQRSTU VWXYZ1234567890!@#\$%^&* _+
ABCDEFGHIJKLMN O PQRSTU VWXYZ1234567890!@#\$%^&* _+

Note: If you use a color ribbon, the self-test should produce one line of each color (black, yellow, red, blue, orange, green, and purple) and then repeat the same sequence of colors until you stop printing. If the test doesn't perform as described or if the colors overlap, continue with the adjustment.



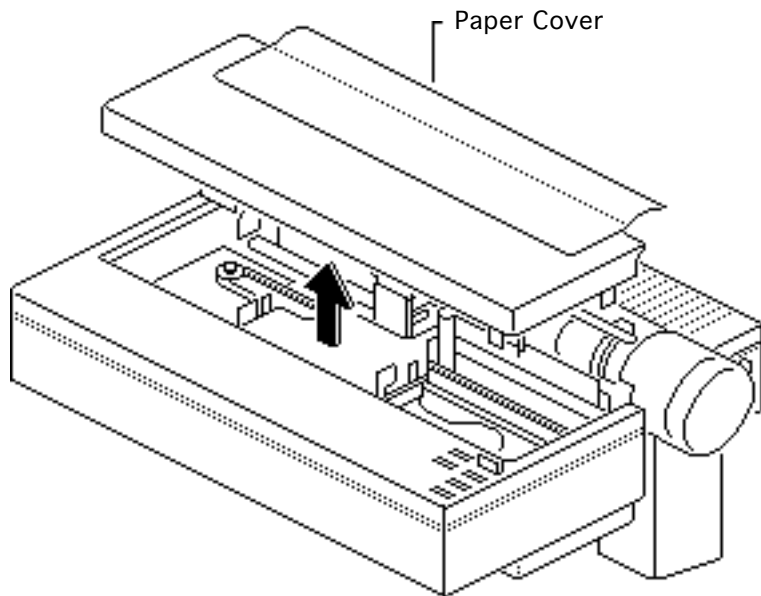

- 2 Switch off the printer and remove the paper cover.



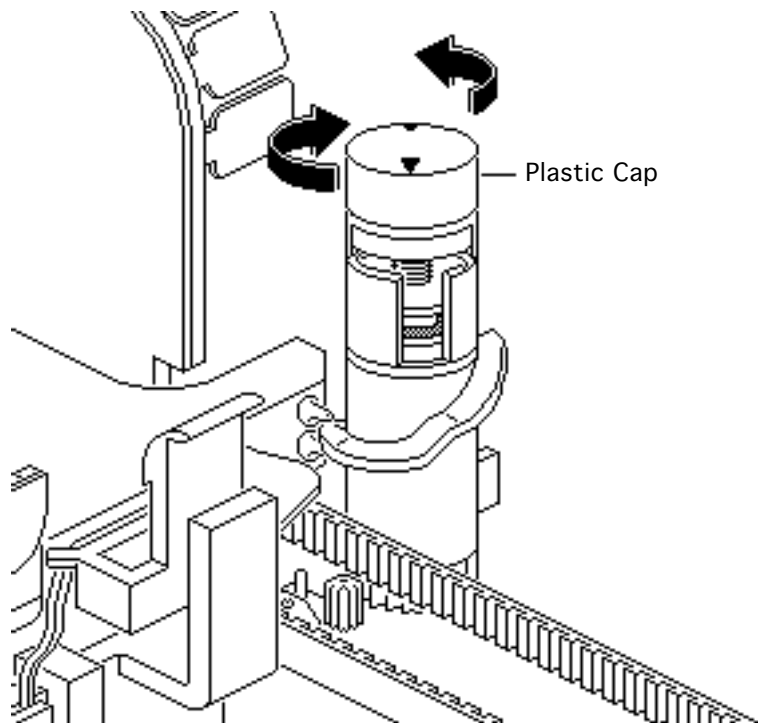

- 3 Examine the self-test printout. The first line should be black.

If the bottom halves of the letters are missing, turn the plastic cap clockwise.

If the top halves of the letters are missing, turn the plastic cap counterclockwise.



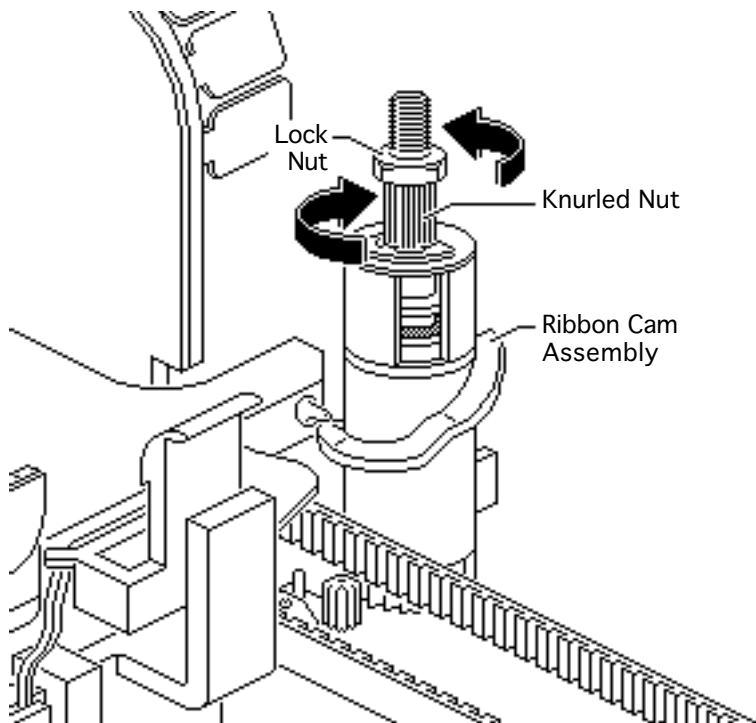

- 4 **Note:** Use the following procedure for systems with the locking nut.
Loosen the lock nut on the ribbon cam.



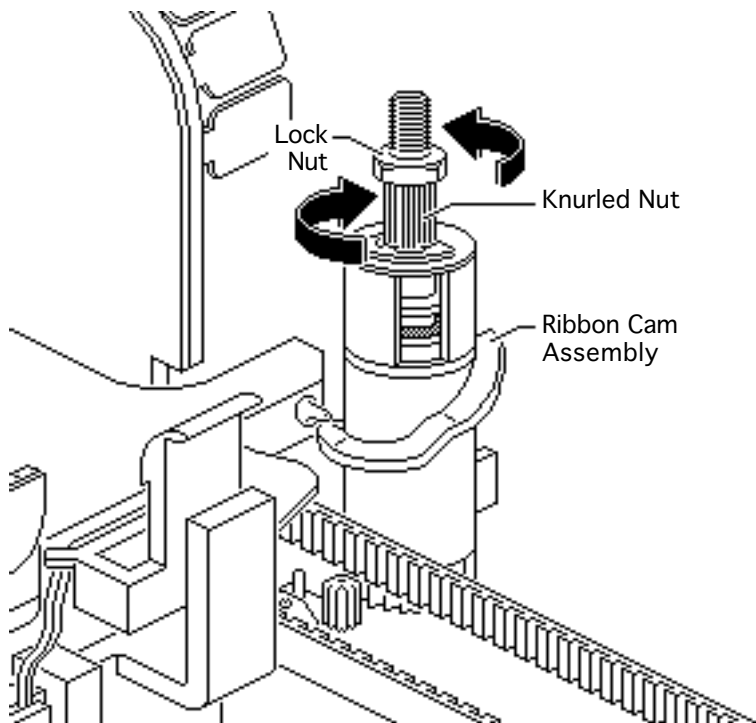

- 5 Examine the self-test printout. The first line should be black.

If the bottom halves of the letters are missing, turn the knurled nut one-half turn clockwise.

If the top halves of the letters are missing, turn the knurled nut one-half turn counterclockwise.

- 6 Tighten the lock nut.





- 7 Run the self-test and examine the printout.

Repeat the adjustment of the ribbon cam until the self-test prints correctly with no overlapping.

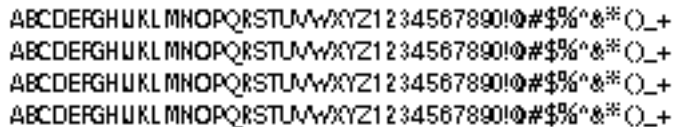

ABCDEFGHIJKLMN O PQRSTU VWXYZ1 234567890!@#\$%^&*()_+
ABCDEFGHIJKLMN O PQRSTU VWXYZ1 234567890!@#\$%^&*()_+
ABCDEFGHIJKLMN O PQRSTU VWXYZ1 234567890!@#\$%^&*()_+
ABCDEFGHIJKLMN O PQRSTU VWXYZ1 234567890!@#\$%^&*()_+





Firing Hammer

No preliminary steps are required before you begin this procedure.

Caution: Review the ESD precautions in Bulletins/ Safety.

Note: Perform the firing hammer adjustment only when you replace the carrier belt, carrier shaft, carrier motor, or main board.

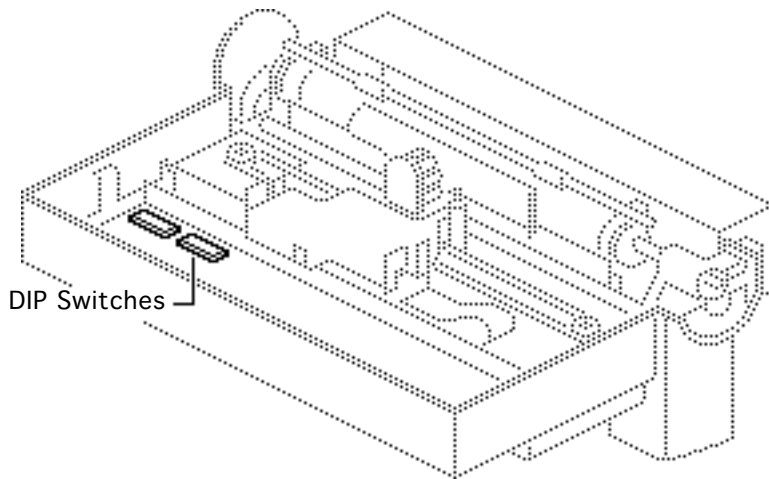



- 1 Print a few lines of the capital letter "H."
- 2 Check the printed letters for misalignment.

Aligned

```
HHHH  
HHHH  
HHHH  
HHHH
```

Misaligned

```
HHHH  
  HHHH  
   HHHH  
    HHHH
```



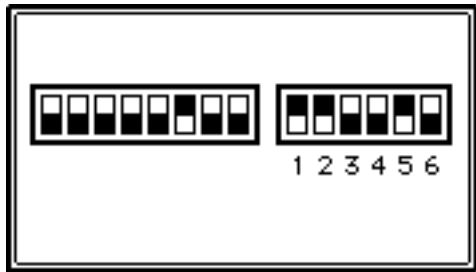

DIP Switches

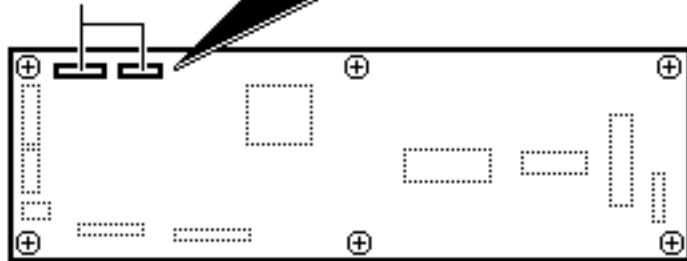

Main Board

- 3 **Note:** Change only one switch at a time.

If the letters are misaligned, remove the covers. Using a small screwdriver, change the settings of DIP switches 2-5 and 2-6.

- 4 Repeat the adjustment until the lines of the capital letter “H” are aligned.





Impression Lever

Before you begin, remove the covers.

Caution: Review the ESD precautions in Bulletins/ Safety.

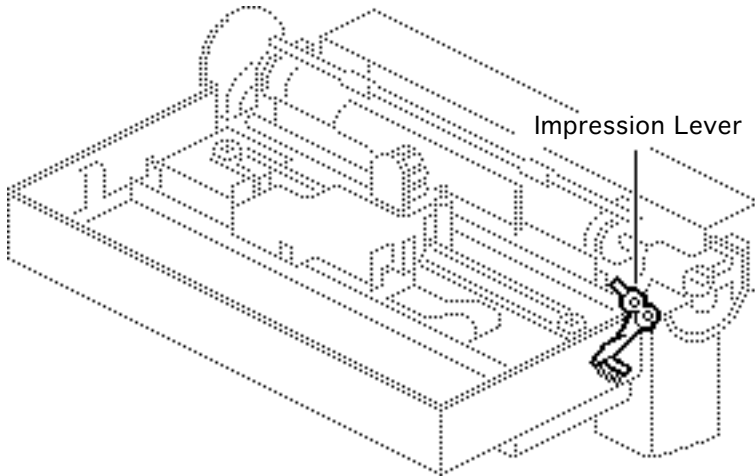

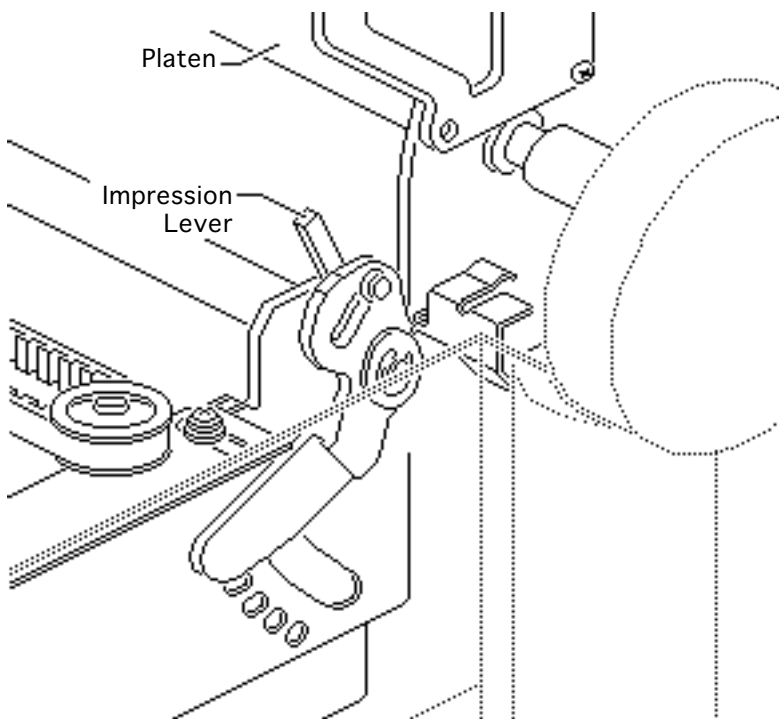

- 1 **Note:** The impression lever moves the print head away from or closer to the platen.

Adjust the position of the lever if the print quality is too light or too dark.



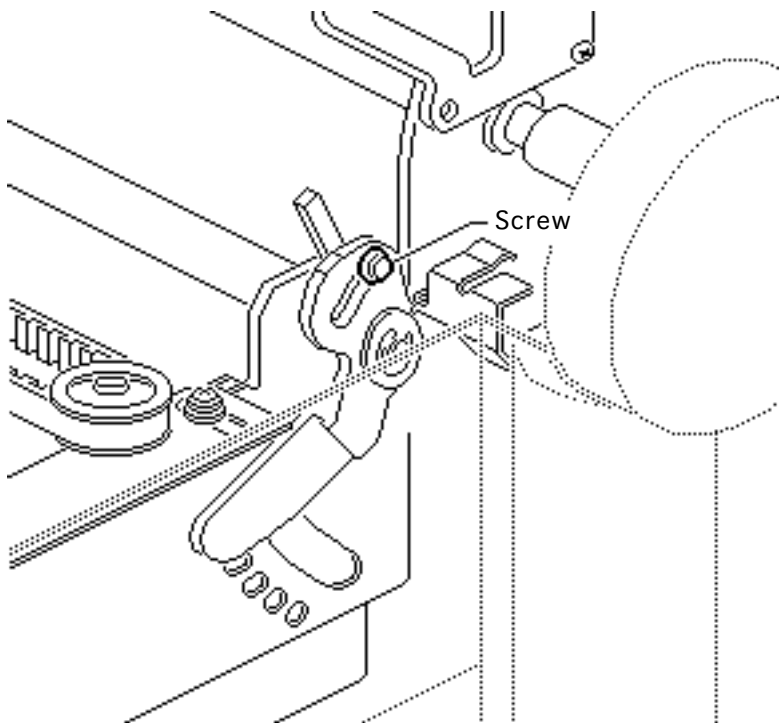

- 2 **Note:** If the print is still too light or too dark after you have moved the impression lever, adjust the screw.

If the print is too light, adjust the screw to the topmost position.

If the print is too dark, adjust the screw to the lowest position.





Drive Belt

Before you begin, remove the following:

- Covers
- Carrier assembly top plate
- Ribbon cam and gears

Caution: Review the ESD precautions in Bulletins/ Safety.

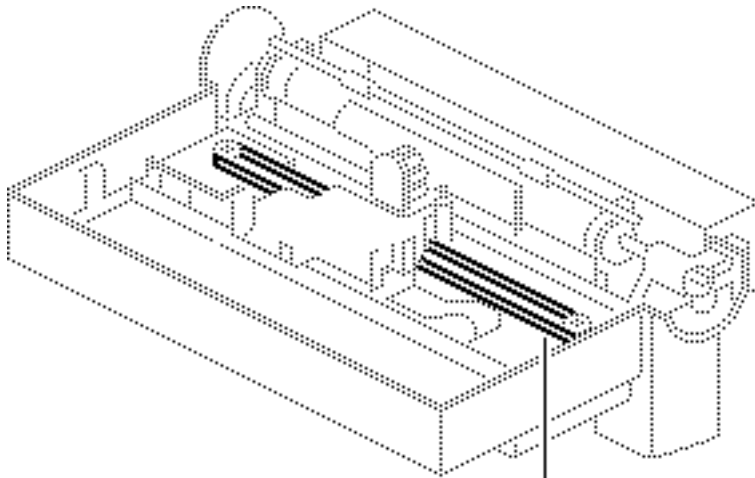

Drive Belt



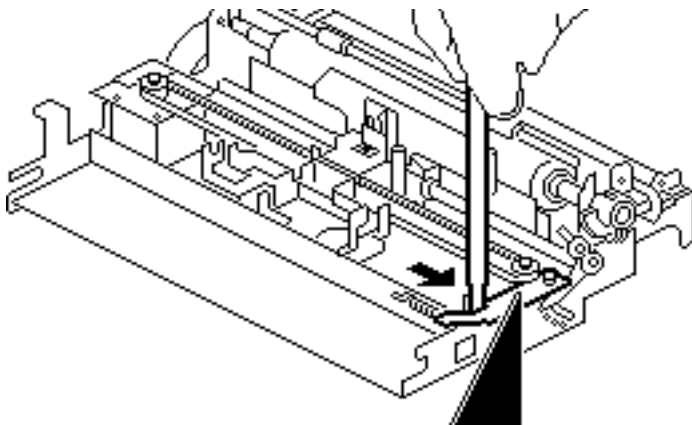

- 1 Loosen the adjustments screw.
- 2 Using a screwdriver, push the carrier pulley arm to the right.
- 3 Hold the pulley arm in position and tighten the adjustment screw.

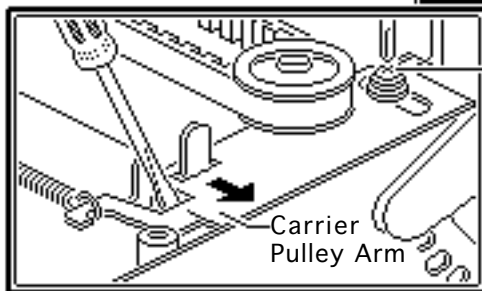

Adjustment
Screw

Carrier
Pulley Arm





Paper Guide

Before you begin, remove the covers.

Caution: Review the ESD precautions in Bulletins/Safety.

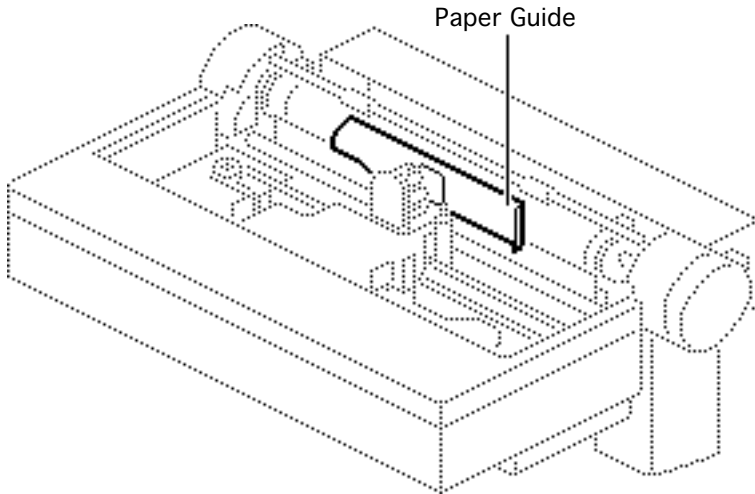

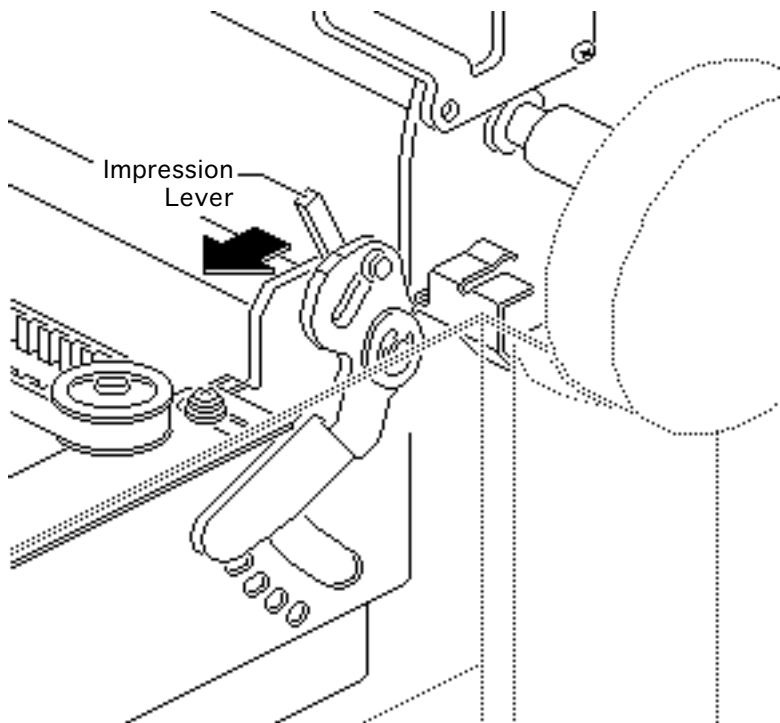

- 1 Slide the impression lever all the way forward.



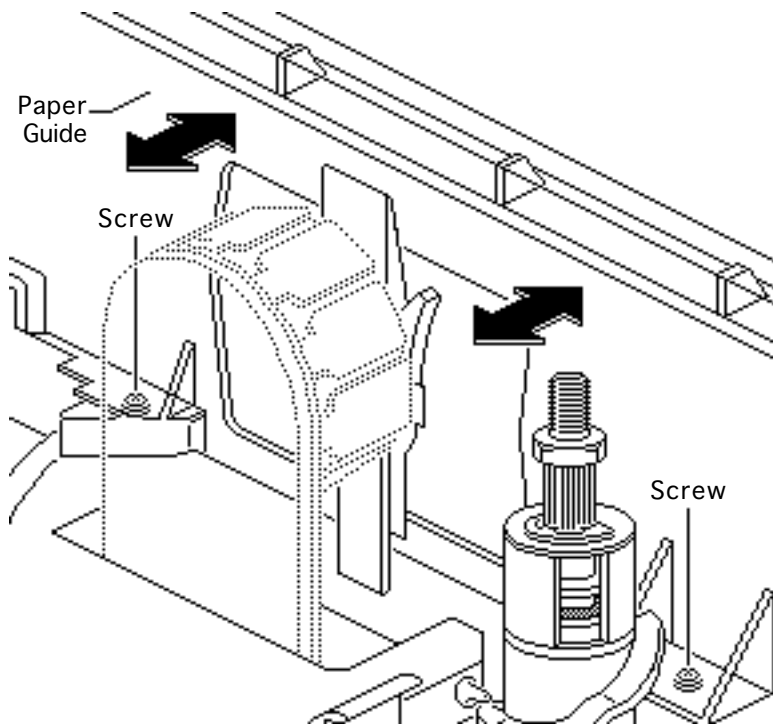

- 2 Loosen the two screws and slide the paper guide forward or backward until the gap is the correct width (approximately .0005 inch or 0.127 mm).
- 3 Tighten the screws.



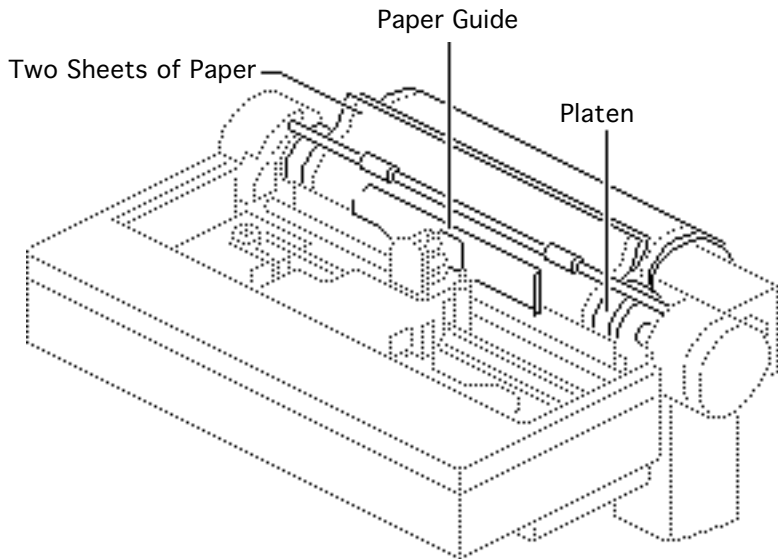

- 4 Roll two sheets of paper under the platen. The paper guide should be snug with little or no movement toward the platen.



