

# Transtar 315

A Vivitar Computer Product

Color Graphics Printer

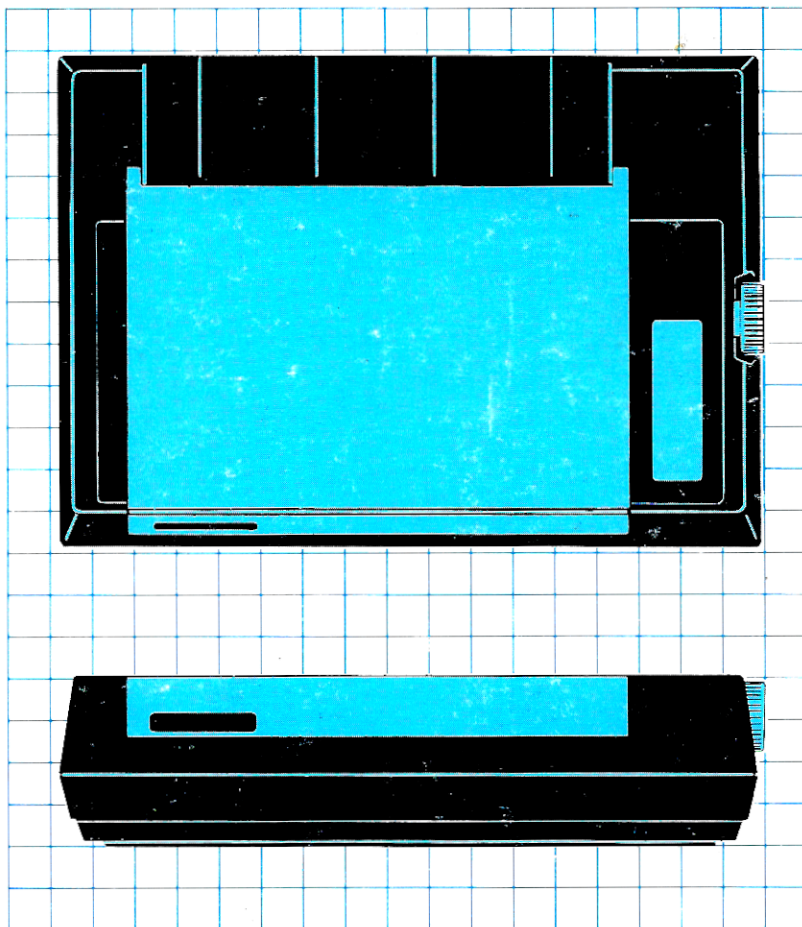

## Operator's Manual

## Installation Checklist

1. Carefully unpack the printer from the box, noting the ribbon, top cover, and paper separator.
2. Lift open the top cover and remove the head lock tube.
3. Install the ribbon according to the directions in Section 2.
4. Load paper into the printer as instructed in Section 2.
5. Plug the power cord into a 110V AC outlet.
6. With the power turned OFF, depress and hold the Line-Feed switch down and turn the power ON. The printer will automatically perform a self-test to check its operation. When the printer stops printing, turn the power OFF.
7. Connect the Transtar 315 to your computer with the cable.
8. Transmit characters to your printer by running one of the sample programs in Section 4.
9. Refer to the Troubleshooting Guide if you encounter any difficulties.
10. Read the Warranty Statement in Appendix F.

# **Transtar 315**

A Vivitar Computer Product

**Color Graphics Printer**

# **Operator's Manual**

The following trademarks are acknowledged in the Transtar 315 Operator's manual:

Apple II/IIe -- Apple Computer, Inc.

Centronics -- Centronics

CP/M -- Digital Research

Mbasic -- Microsoft

IBM PC -- International Business Machines

Transtar -- Transtar

Softcard -- Microsoft

Version 2.0  
Second Printing July 1983

Copyright 1983  
Vivitar Computer Products  
2100 116th Avenue N.E.  
P.O. Box C-96975  
Bellevue, Washington 98009  
phone (206) 454-9250

Printed in the United States of America

Transtar and Seikosha reserve the right to change the contents as stated herein at any time and without notice. Although every effort has been made to insure that the contents as stated herein are complete and without error, Transtar and Seikosha cannot be responsible for any damage that may occur should this not be the case.



# Table of Contents

---

|   |           |
|---|-----------|
| Installation Checklist                                  |           |
| FCC Notice  |           |
| <b>Introduction</b>                                     | <b>1</b>  |
| <b>Part 1: Getting Acquainted with the Transtar 315</b> | <b>2</b>  |
| Product Description                                     | 2         |
| Specifications  | 3         |
| Parts of the Printer                                    | 4         |
| <b>Part 2: Installation and Use</b>                     | <b>7</b>  |
| Installing and Removing the Ink Ribbon Cassette         |           |
| Ink Cartridge Replacement                               |           |
| Loading Paper   |           |
| continuous forms  |           |
| single sheets   |           |
| Head Position Adjustment                                | 14        |
| Self-test Printing                                      | 15        |
| Automatic Printing Function                             | 15        |
| Error Conditions  | 15        |
| Caring for your Printer                                 | 16        |
| <b>Part 3: Configuring your Printer</b>                 | <b>17</b> |
| Making a Cable  | 18        |
| Electrical Condition                                    | 20        |
| Timing Chart  | 21        |
| Setting the Dip Switches                                | 22        |
| <b>Part 4: Programming your Printer</b>                 | <b>23</b> |
| <b>Appendix A: Using the Optional PICS Interface</b>    | <b>55</b> |
| <b>Appendix B: ASCII Code Table</b>                     | <b>58</b> |
| <b>Appendix C: Troubleshooting Guide</b>                | <b>59</b> |
| <b>Appendix D: Color Tips</b>                           | <b>61</b> |
| <b>Appendix E: Using the PICS Card Under CP/M</b>       | <b>62</b> |
| <b>Appendix F: Warranty Statement</b>                   | <b>65</b> |
| <b>Glossary</b>   | <b>66</b> |
| <b>Index</b>  | <b>67</b> |
| <b>User Comment Form</b>                                | <b>69</b> |

# Introduction

---

**Part 1** of this manual will acquaint you with your new Transtar 315 color printer, its physical aspects and specifications. **Part 2** shows you how to use the printer in everyday applications. **Part 3** provides the information you need to do the initial set-up of the printer. **Part 4** provides technical details for those persons interested in programming the Transtar 315. Appendices, a glossary of selected terms, and an index will provide further assistance as you learn to use the Transtar 315.

# Part 1

---

# Getting Acquainted with the Transtar 315

## Product Description

The Transtar 315 color printer provides color text and graphics at an affordable price. Its special programming code and design make it simple to use. Seikosha's unique "four-hammer" technology provides 7-color mixing in a single pass of the printhead.

The Transtar 315 uses a Centronics® -compatible parallel interface. An optional Apple II/IIe® and Franklin® PICS interface allows for software-independent graphics printing. Thus, most business and entertainment programs can be printed by simply depressing the printer's COPY button. The optional Serial Interface Board allows for interfacing with computers that do not provide a parallel connector.

## Specifications

### 1. Printing specifications

|                       |  |
|-----------------------|--|
| Printing method       | Impact type dot matrix<br>(Seikosha's unique 4-hammer method)  |
| Printing direction    | Unidirectional (left to right)   |
| Printing colors       | Black, cyan, purple, magenta, red, yellow,<br>green (colors can be specified down to the<br>individual dot level)  |
| Character composition | 5 x 8 (horiz x vert) + 1 dot space<br>7 x 8 (horiz x vert) + 1 dot space   |
| Character types       | Alphanumeric English character set and symbols   |
| Character size        | .8" x .9" (horiz x vert) 10.0 cpi<br>.6" x .9" (horiz x vert) 13.3 cpi   |
| Character spacing     | 10 cpi and 13.3 cpi  |
| Characters per line   | 80 cpl and 106 cpl   |
| Printing speed        | 38 cps and 50 cps  |
| Line spacing          | 1/6, 1/8 and N/120 inch (software selectable)  |
| Number of copies      | Original + 2 copies (15 lb. paper)<br>(color is only on the original)  |
| Graphics              | Arbitrary combinations of any color of dot in<br>in an 8-dot column with up to 640 columns<br>per line. Text and graphics can be mixed on<br>the same line |

### 2. Paper feed specifications

|                      |   |
|----------------------|---|
| Paper feed direction | Forward direction only, loaded from the rear  |
| Minimum line feed    | 1/120 of an inch  |
| Line feed speed      | 10 lines per sec (1/6" continuous line feeds)<br>15 lines per sec (1/10" continuous line feeds) |
| Paper feed method    | Pin feed and friction feed used together.   |

### 3. Ink ribbon specifications

|                                 |                              |
|---------------------------------|------------------------------|
| Cassette type                   | Order #TR-70050              |
| Ink colors                      | Black, cyan, magenta, yellow |
| Individual re-inking cartridges | Set of four, order #TR-70500 |

### 4. Operating environment

|                     |  |
|---------------------|--|
| Power supply        | 120, 220/240 VAC $\pm$ 10% 50/60 Hz                          |
| Power consumption   | 30 watts (continuous printing of text)<br>13 watts (standby) |
| Temperature         | 41°F – 104°F   |
| Humidity            | 20% – 80% (no condensation)                                  |
| External dimensions | 17.7"W x 4.4"H x 12.6"D<br>(15.5"D with paper shelf)         |
| Weight              | 13.2 lbs   |



## Parts of the Printer

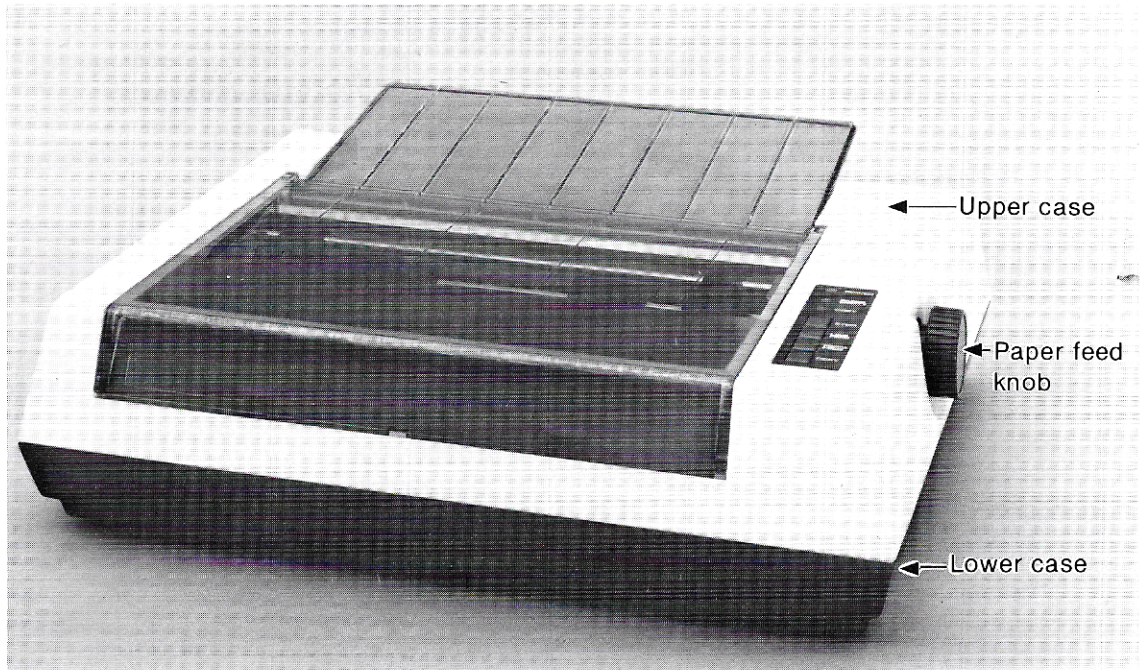

Figure 1

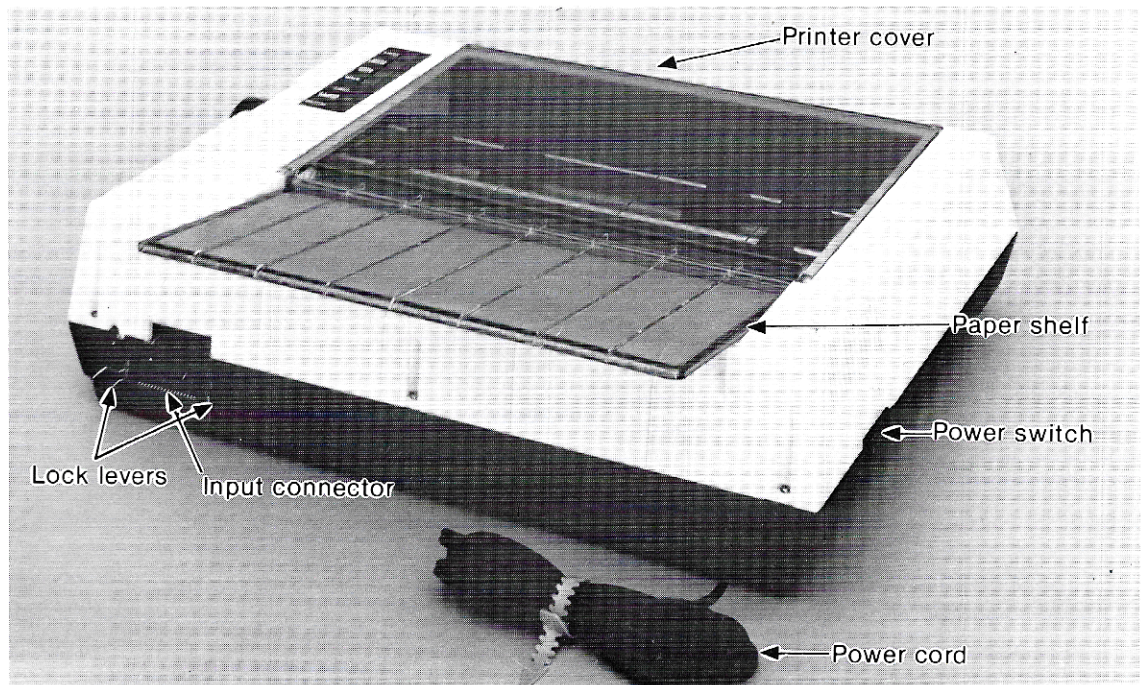

Figure 2



## Operator Switches and Indicators

### 1. POWER switch

The power switch is located on the left side of the printer toward the rear.

### 2. STOP switch

a) Pushing the STOP switch causes the printer to stop, or if stopped, it clears the STOP condition.

b) Pushing the STOP switch the first time causes the PAPER EMPTY light to blink on and off, and temporarily stops printing.

c) If the STOP switch is pushed while doing a screen copy, the COPY lamp blinks and the screen copy is temporarily halted. Pushing the STOP switch again causes the STOP condition to be cleared and printing resumed.

\* The screen copy condition does not function without the optional PICS interface board.

### 3. LINE FEED switch

a) A 1/6 inch line feed is executed each time it is pushed.

b) If held down, line feeds are continuously executed.

c) Line feeds are performed only in the STOP condition.

### 4. FORM FEED switch

a) Pressing this switch causes a form feed to the top of the next page or next Top of Form.

b) This switch is valid only in the STOP condition.

### 5. COPY switch

a) Pressing this switch causes a screen copy to occur.

b) After a single screen copy is complete, the copying condition is automatically terminated.

c) If the STOP condition is entered during a screen copy process, pushing this switch will reset the screen copy condition.

\* Without the optional PICS card, this switch does not function.

### 6. POWER lamp (red)

a) This lamp is on when the power is on.

b) It blinks during an error condition.

### 7. PAPER EMPTY lamp (red)

a) This lamp blinks when the printer is out of paper. The Paper Empty signal is output to the host device.

b) It also blinks when the STOP switch is pressed (except when pressed during a screen copy).



- c) When a PAPER EMPTY condition occurs, insert paper and push the STOP switch to clear the PAPER EMPTY condition.
- d) When blinking because the STOP switch was pressed, press the STOP switch again to clear the condition.
- e) When a PAPER EMPTY condition occurs, pressing the STOP switch prints the data up to one print command. But when the paper is fed more than or equal to 128/120 inches (for instance, 7 lines in 1/6 inch line feed mode), printing won't be executed unless paper is inserted to clear the PAPER EMPTY condition.

### 8. COPY lamp (green)

- a) This lamp blinks when a screen copy starts.
- b) It stops blinking when a screen copy terminates.
- c) The lamp blinks when the STOP switch is pressed during a screen copy. Pressing the STOP switch again causes the lamp to stay on and the screen copy to continue.
- d) If the COPY switch is pressed while the lamp is blinking, the screen copy condition is reset and the lamp goes out.

\*Without the optional screen copy board, the lamp remains off.

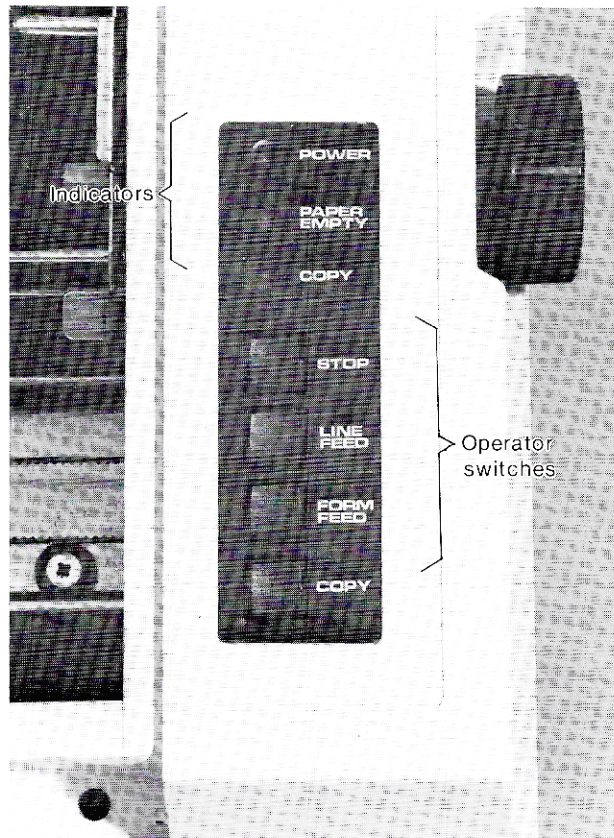

Figure 3

# Part 2

---

## Installation & Use

## Installing and Removing the Ink Ribbon Cassette

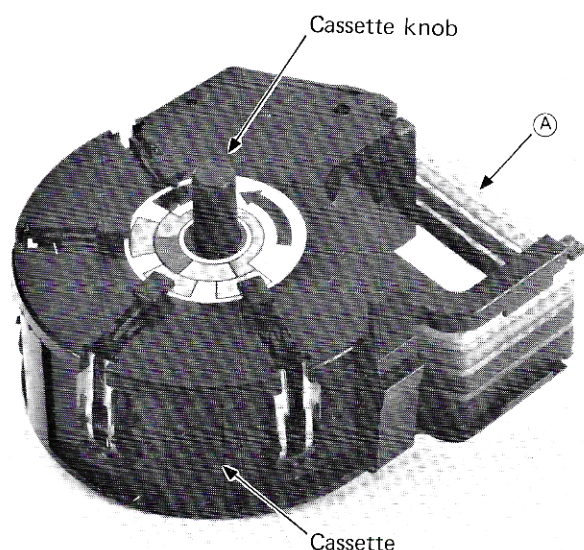

Figure 4

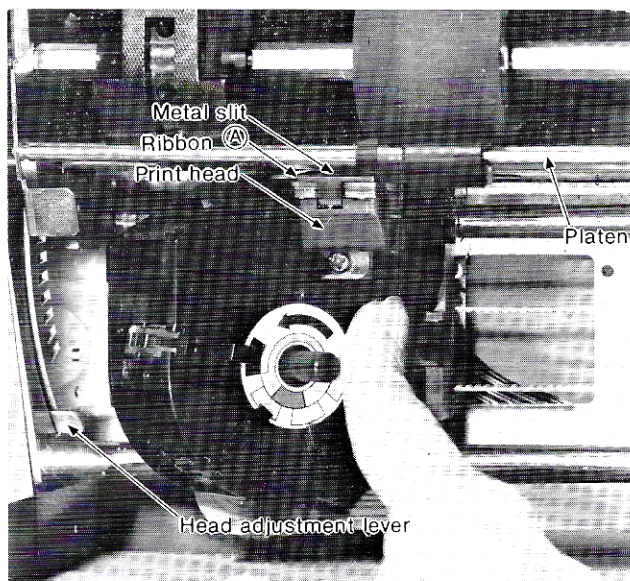

Figure 5

### 1. Installation

- a) Unwrap the ribbon cassette.
- b) Turn the cassette knob in the direction of the arrow to draw the ribbon taut (figure 4).
- c) Move the head adjustment lever all the way toward the front of the printer. (This moves the printhead away from the platen.)
- d) To insert the ribbon cassette, hold the cassette at an angle (figure 5) and put into position from the right side. The A portion of the ribbon must slide between the printhead and the metal slit.
- e) Push on the lower right side of the cassette with the index finger as shown in figure 5. The cassette should click into place. If you don't hear a click, turn the cassette knob a little more in the direction of the arrow and press again on the right side of the cassette until it clicks. With the cassette installed, turn the cassette knob again in the direction of the arrow to tighten the ribbon.
- f) Return the head adjustment lever to its original position.



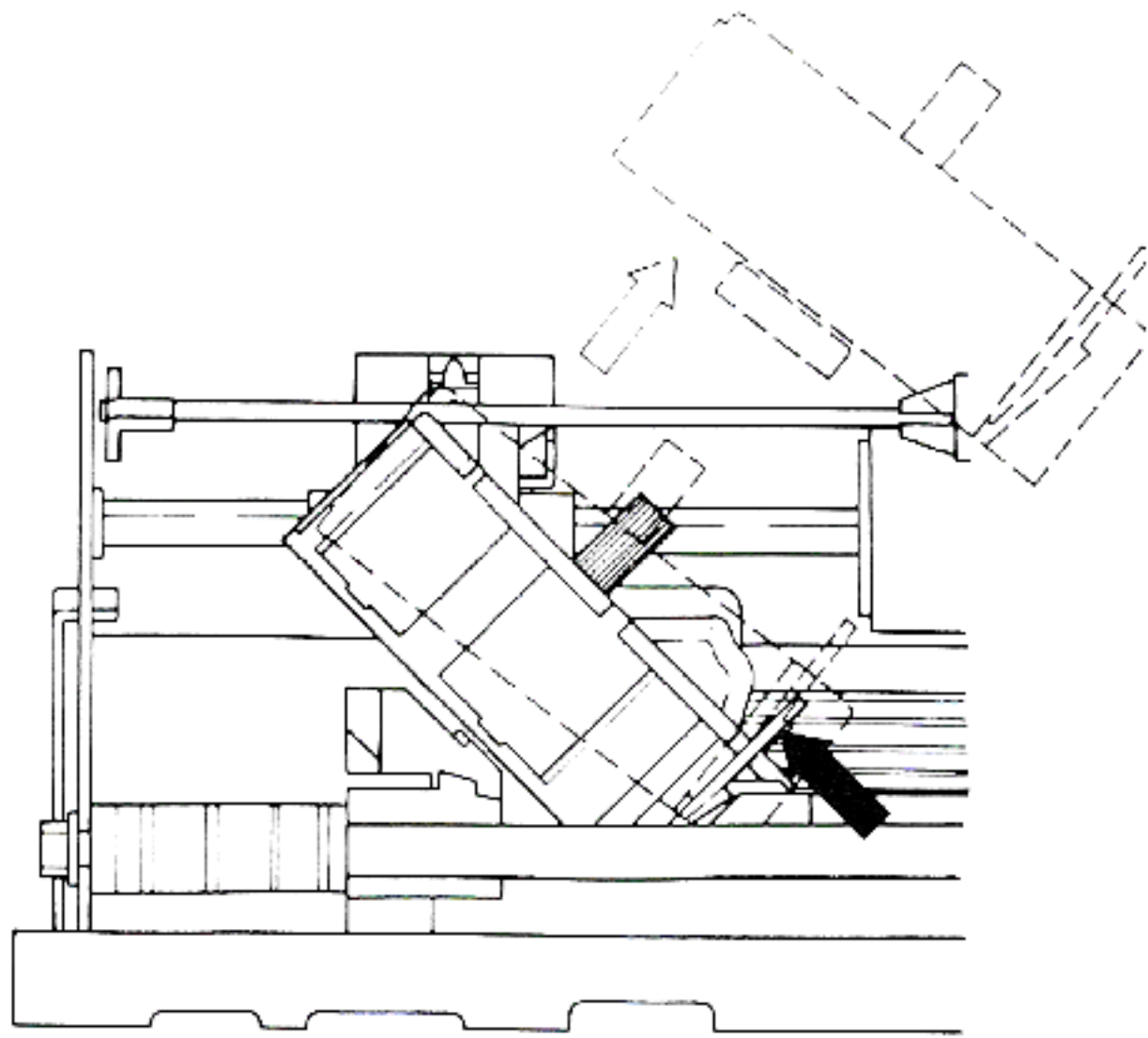

Figure 6

g) Figure 6 illustrates a front view of the ribbon cassette installation. The white arrow shows the direction for putting the cassette on the carrier, and the black arrow shows where to press in order to snap the cassette into position.

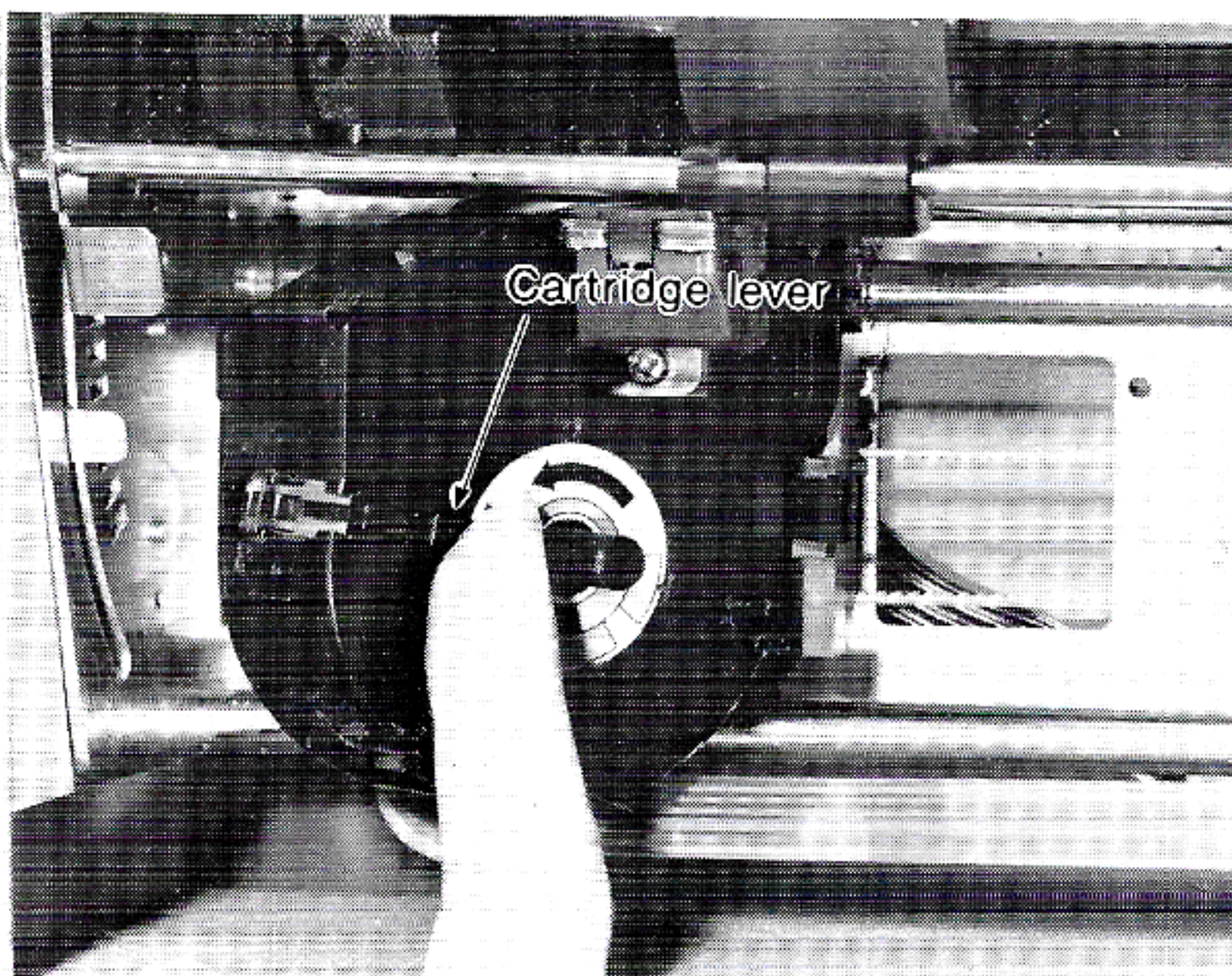

Figure 7

h) If a given ink color is not going to be used, the transfer of ink from that cartridge to the ribbon can be turned off by pushing the respective cartridge lever (figure 7) toward the outside of the cassette. Pushing in the cartridge lever starts the transfer of ink again.

It is important to turn off the ink transfer from unused colors. Failure to do so will cause over inking of the ribbon leading to streaking.

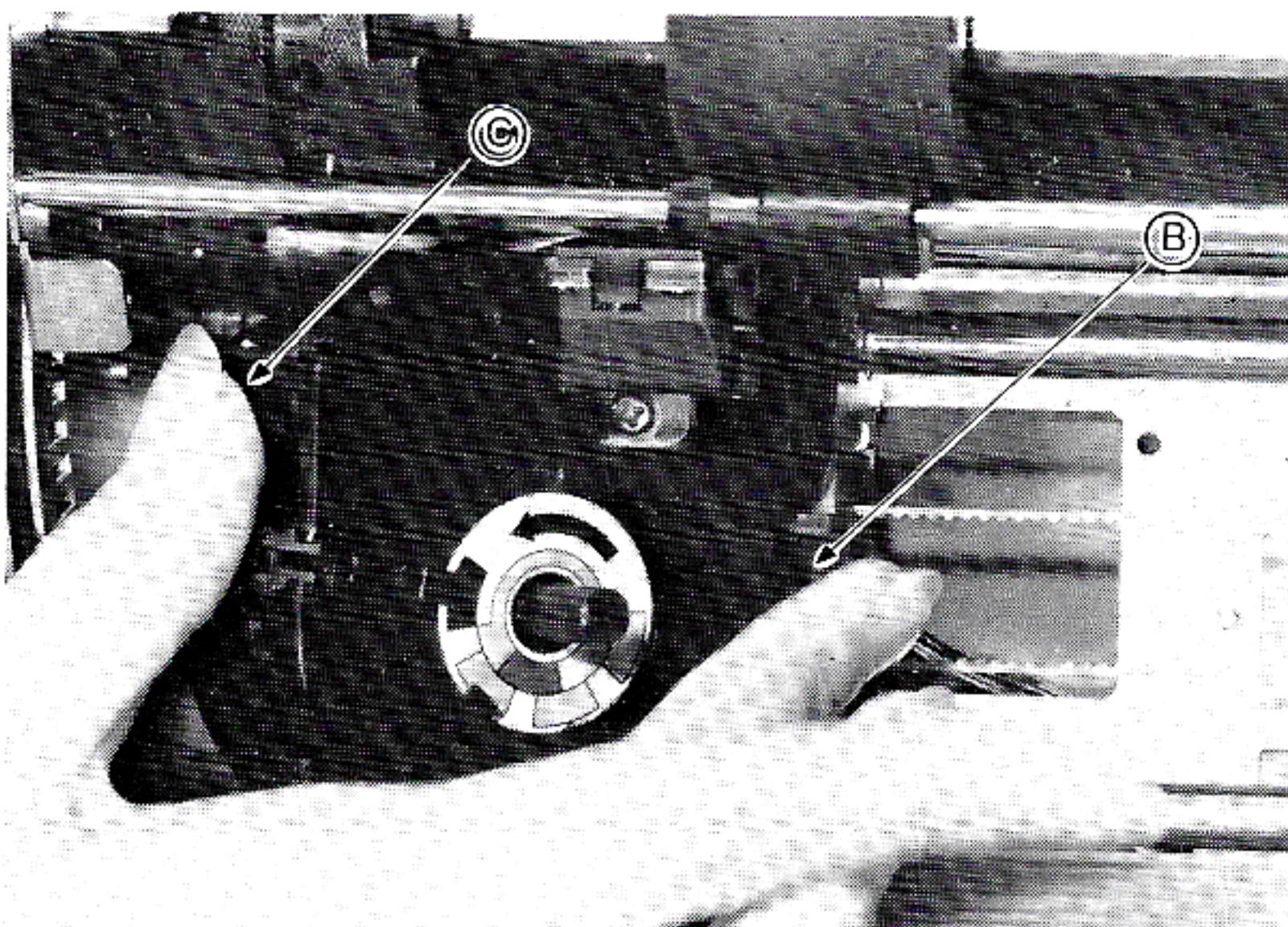

Figure 8

## 2. Removal

a) The ink cassette is easily removed by grasping the cassette as shown in figure 8 with the thumb on part C and the middle finger on part B, squeezing gently, and lifting up. The cassette knob should be turned in the direction of the arrow to tighten the ribbon.



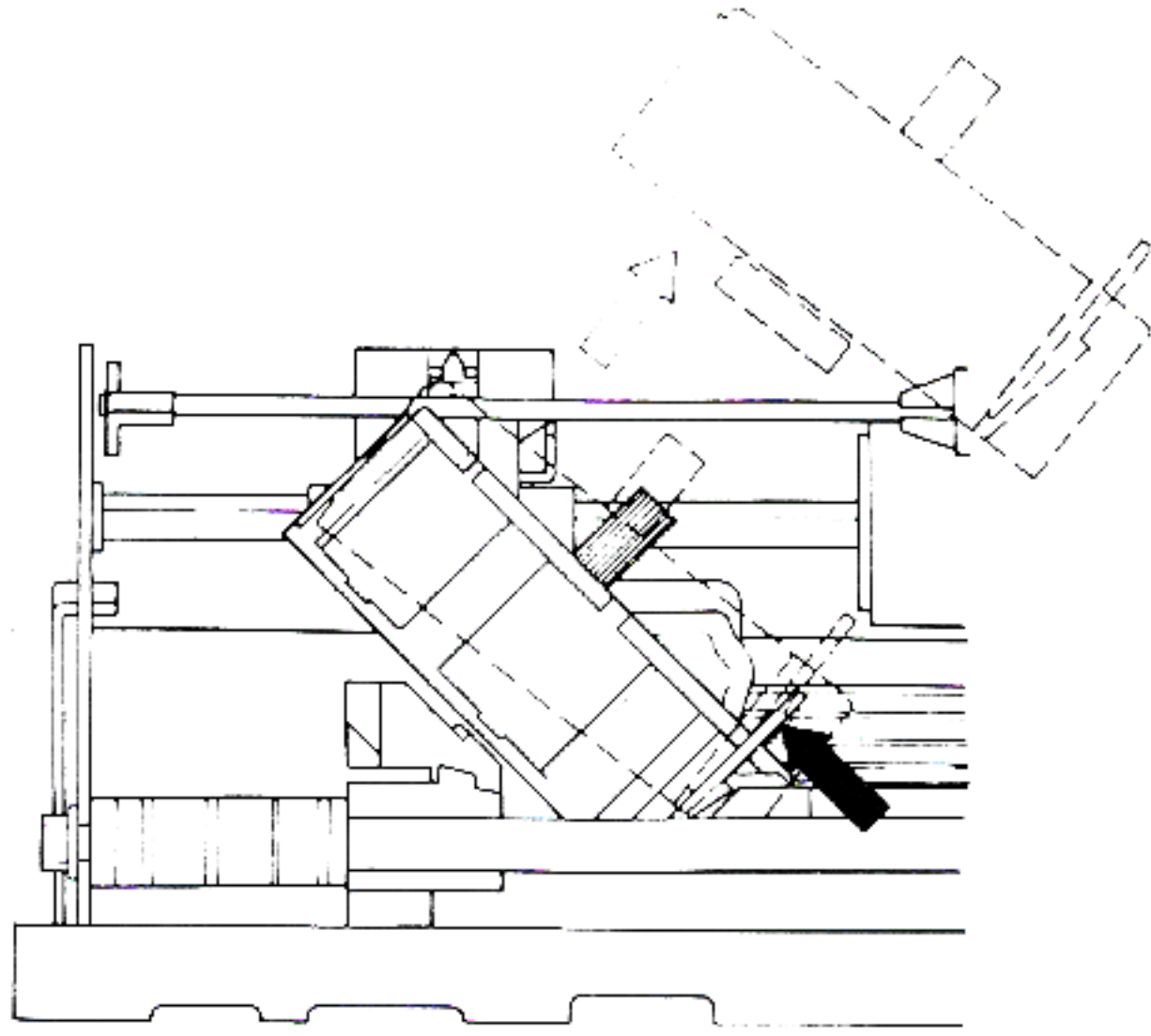

Figure 9

b) Figure 9 shows the removal of the ribbon cassette. Press the part indicated by the black arrow to tighten the ribbon, and raise the cassette in the direction of the white arrow.

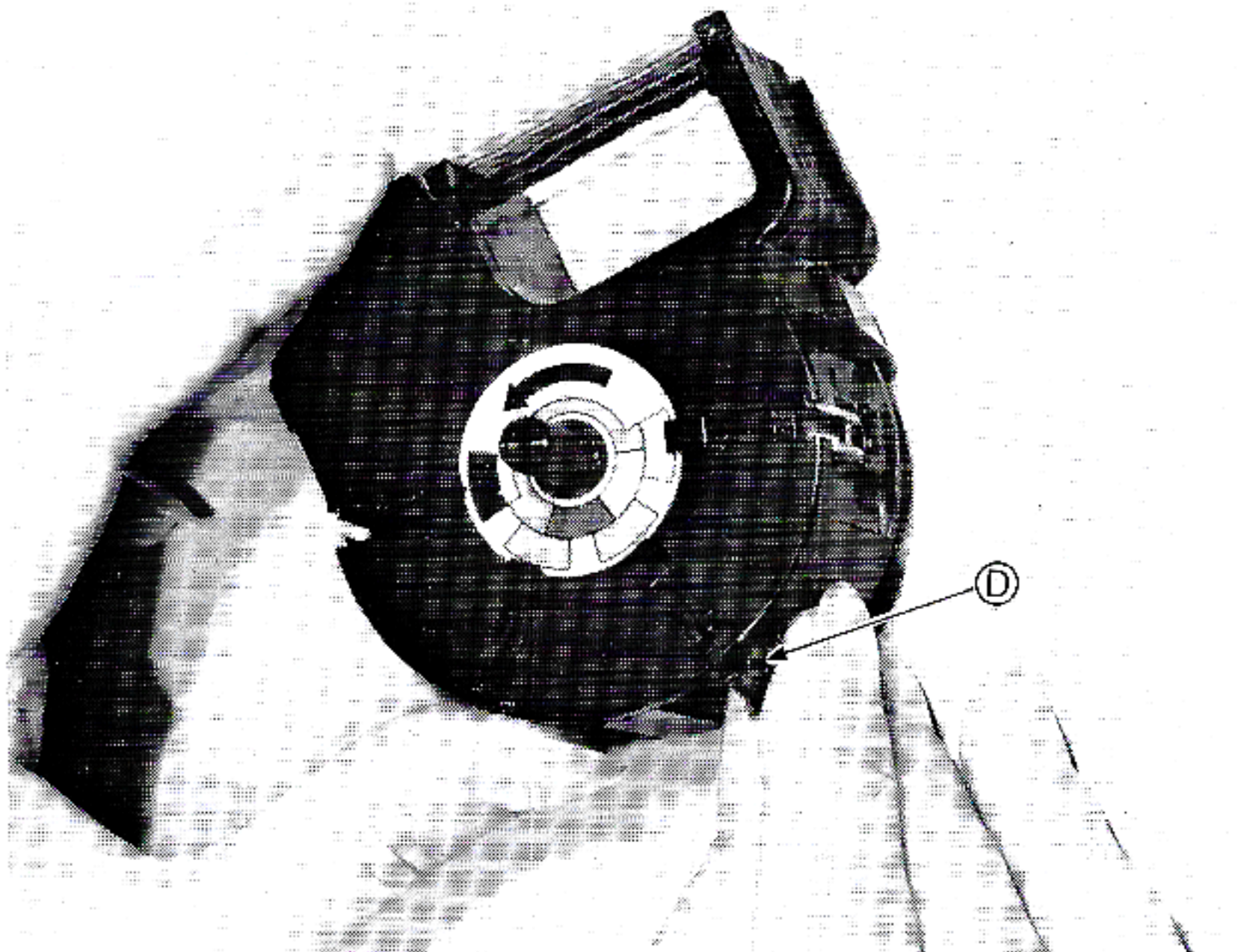

Figure 10

### 3. Ink cartridge replacement

a) The T315 cassette is designed so that a single ink cartridge can be replaced when that particular color is used up. Remove the cartridge by gently pinching inward on the metal clip D as shown in figure 10.

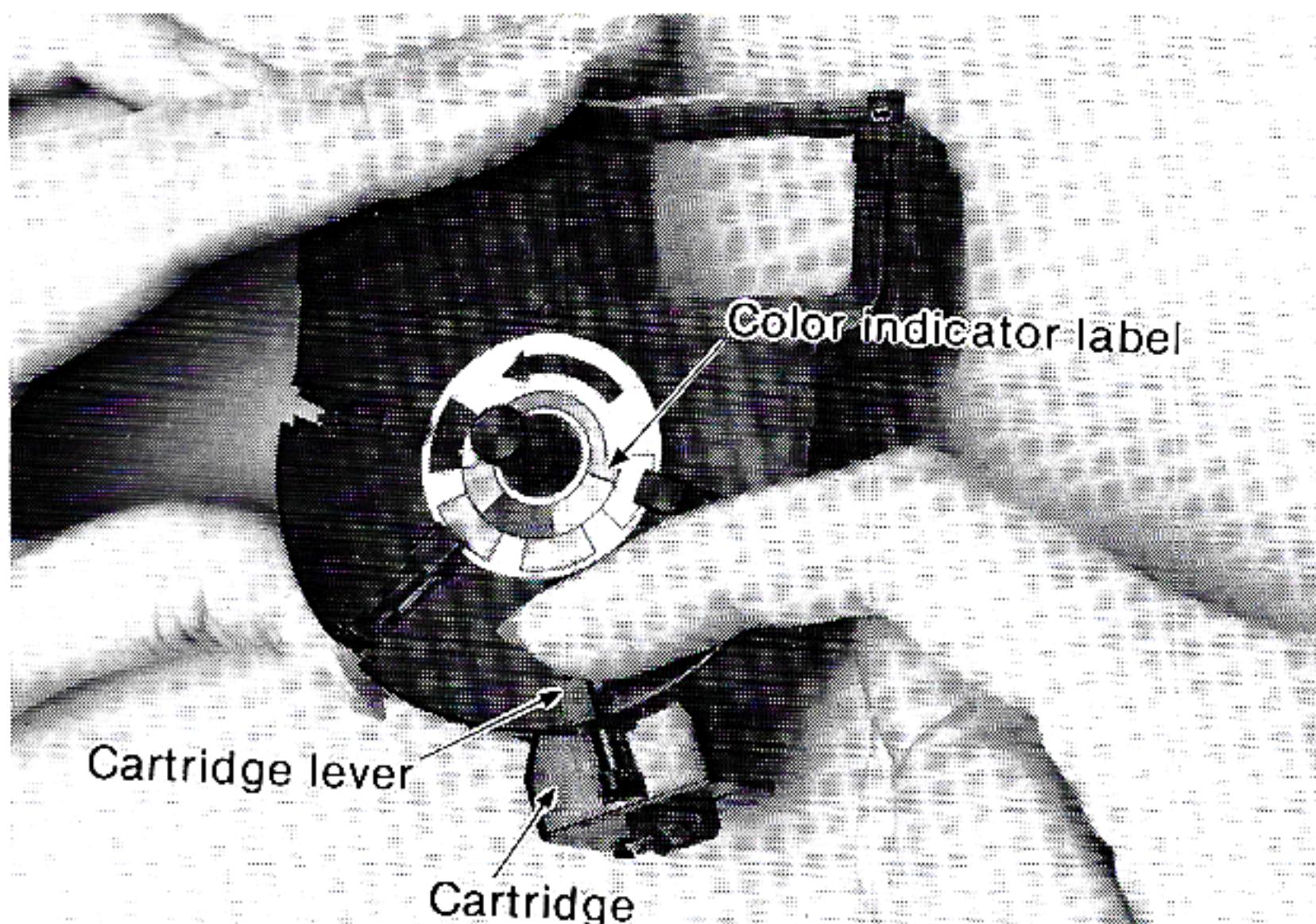

Figure 11

b) Then push outward on the cartridge lever as shown in figure 11. Insert the new ink cartridge. (Be sure that the color of the new ink cartridge matches the color indicator label on the top of the cassette.) Pinch the metal clip gently and set it into place.



## Loading the Paper

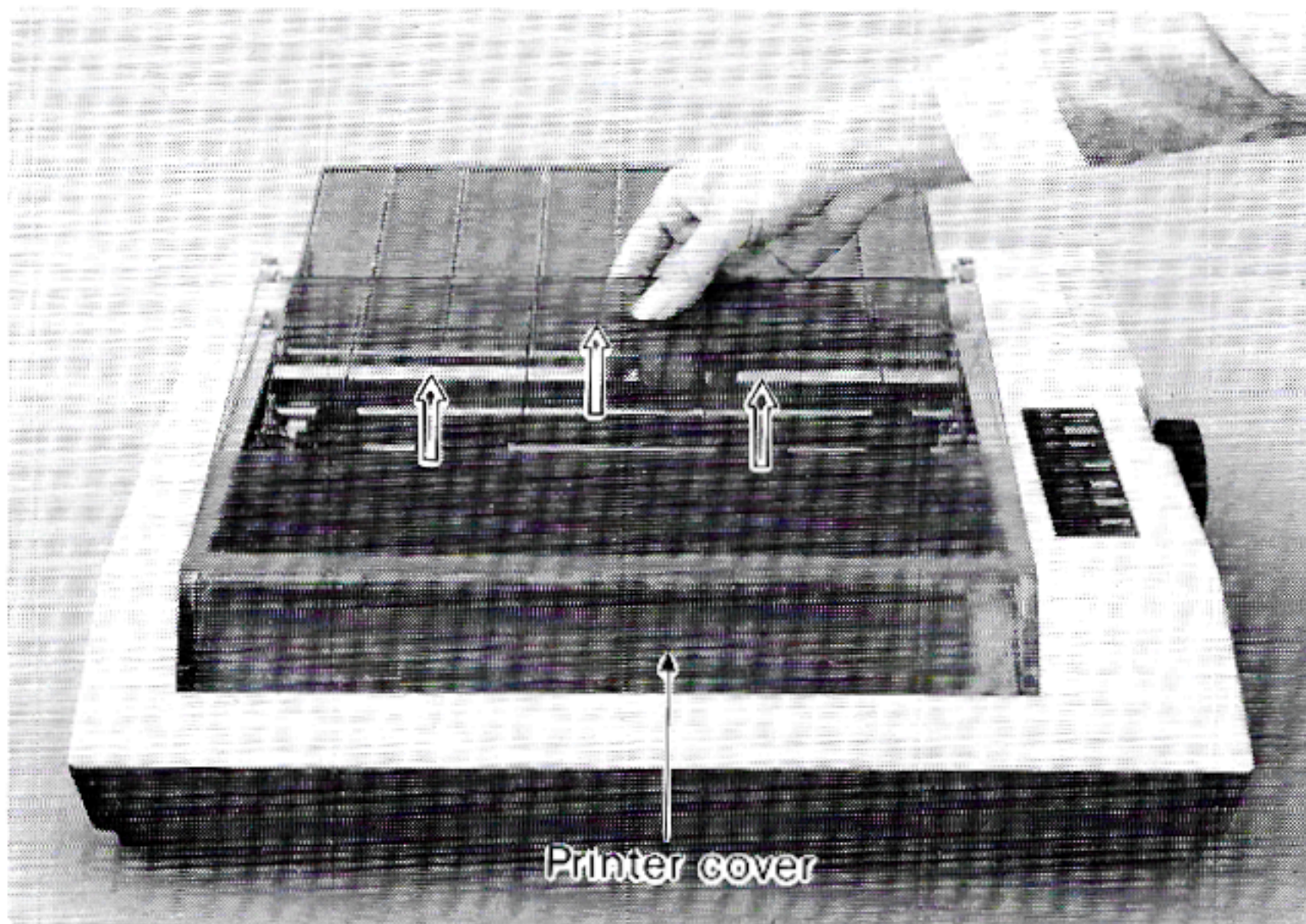

Figure 12

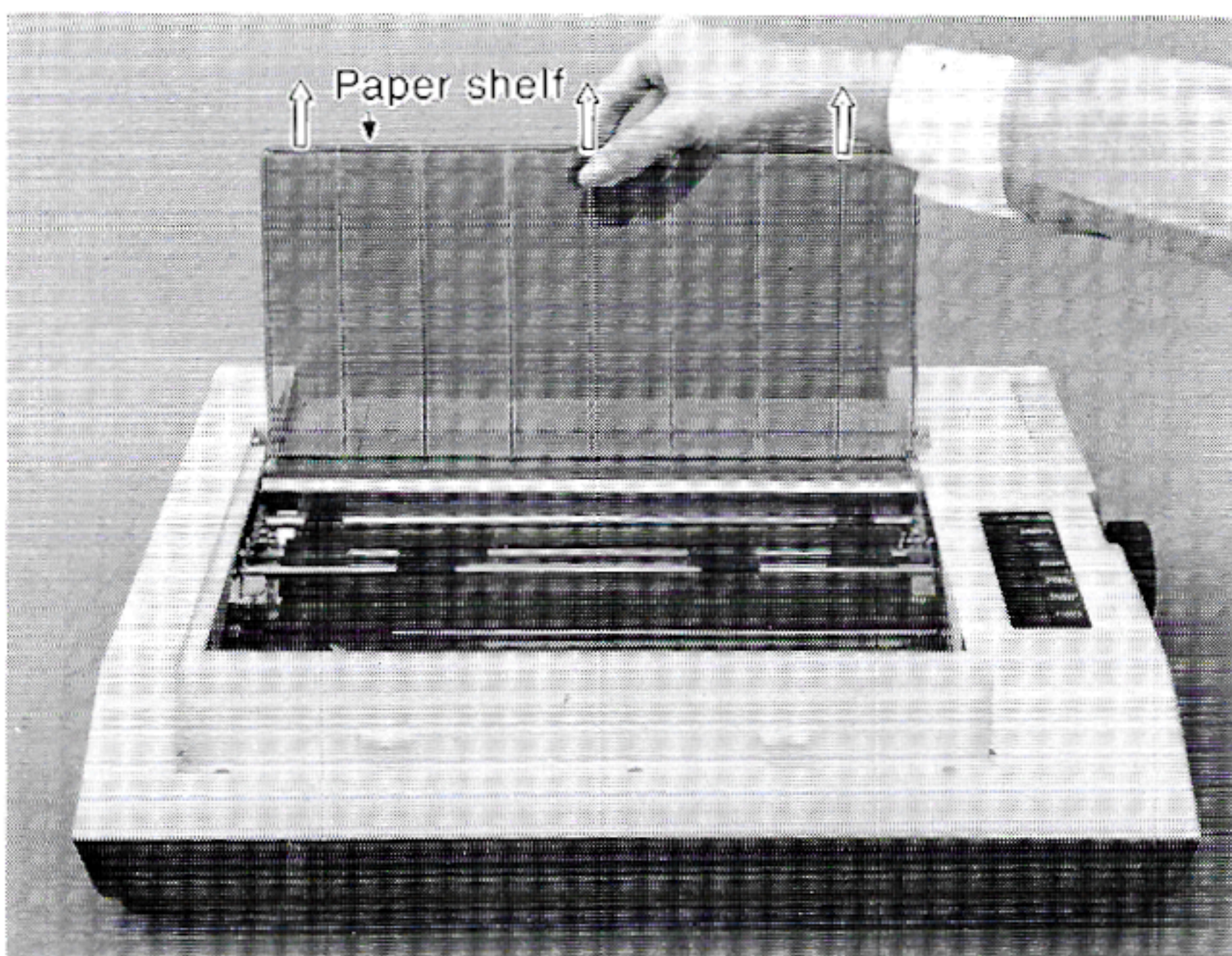

Figure 13

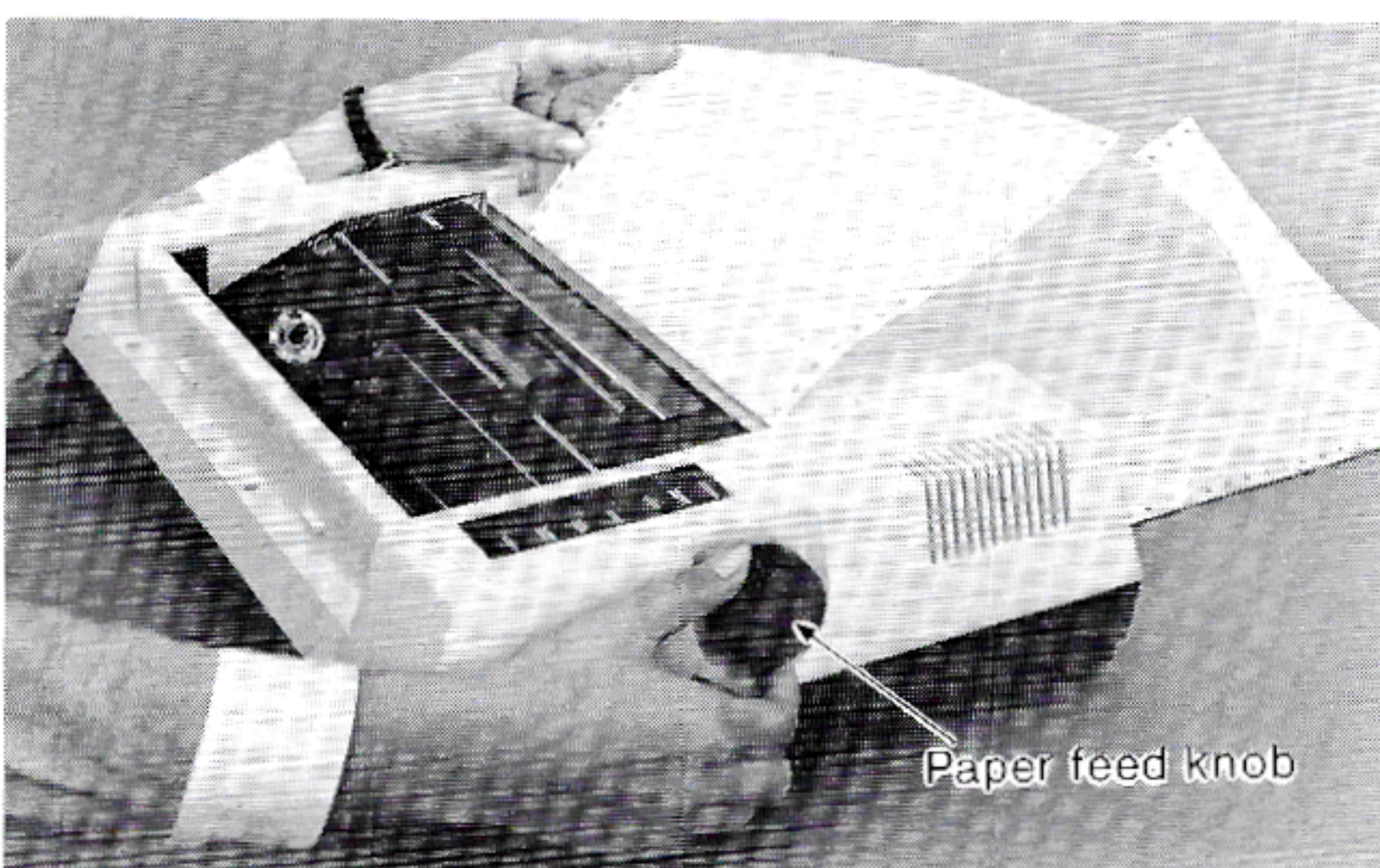

Figure 14

### 1. Continuous forms

a) Grasp the back of the printer cover and remove it by lifting upwards (figure 12).

b) Rotate the paper shelf to a vertical position and remove it by lifting upwards (figure 13). Move the head adjustment lever all the way toward the front of the printer (refer to the section on the Head Position Adjustment).

c) Use both hands to insert the paper from the rear and turn the right paper feed knob in a clockwise direction (figure 14). This causes the paper to feed around the printhead and the platen.

Note that the paper feed knob can be rotated in either the clockwise or counter-clockwise direction.



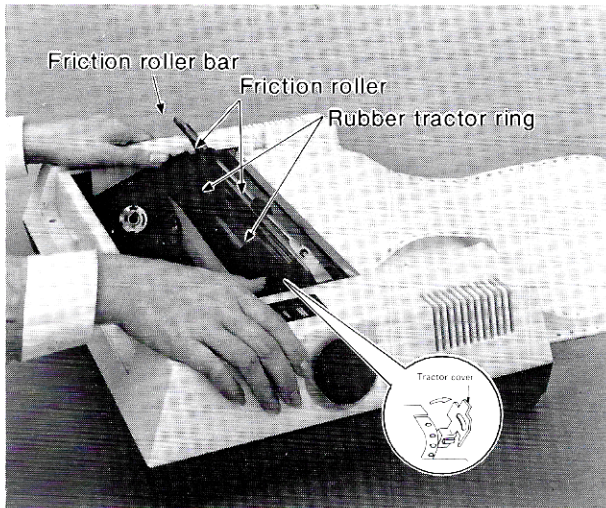

Figure 15

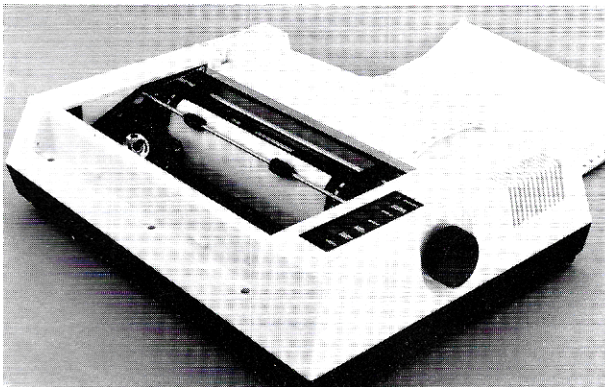

Figure 16

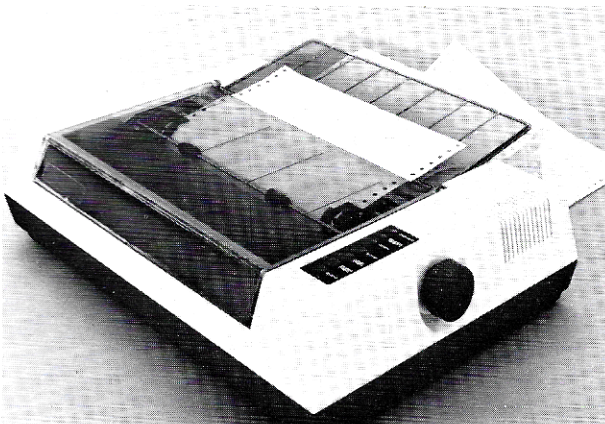

Figure 17

d) Next, lift up the friction roller bar and open the left and right tractor covers by lifting them up and turning them to the outside (figure 15).

e) With the holes along both edges of the paper matched up with the paper feed pins on the left and right tractors, close the tractor covers. Lower the friction roller bar, positioning the friction rollers on the bar so that they rest directly on top of the two large rubber tractor rings (figures 15 and 16).

If the tractor spacing does not match the paper width, slide the tractors to the left or right as needed. Make sure that the paper is positioned so that the first and last print positions are on the paper.

f) Return the head adjustment lever to its original position. Replace the paper shelf and printer cover in that order (figure 17). Adjust the print position by turning the paper feed knob.



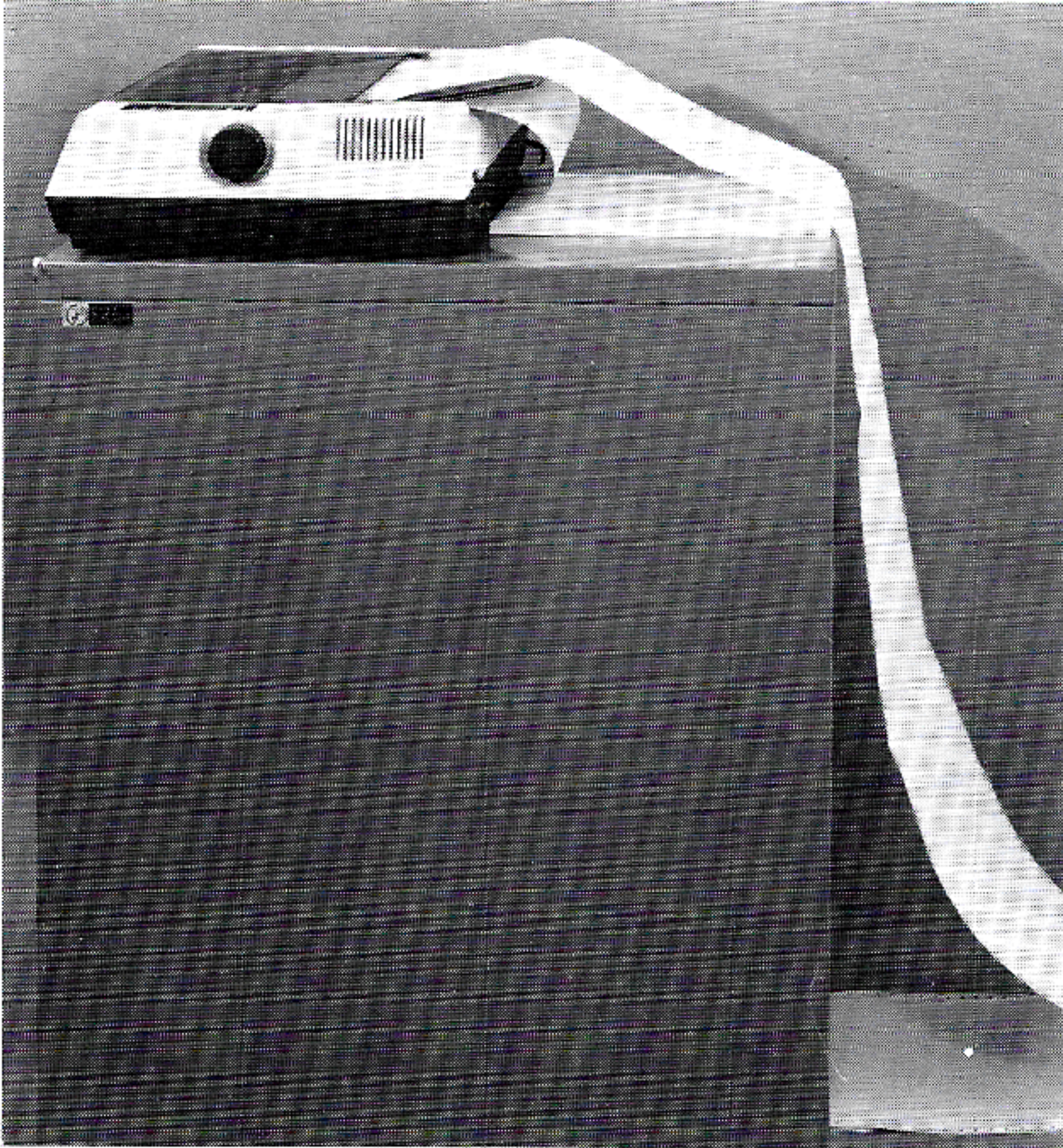

Figure 18

When using continuous forms, the paper supply should rest on the same surface as the printer, and the printed paper should go to a lower position, such as the floor or a paper catch tray.

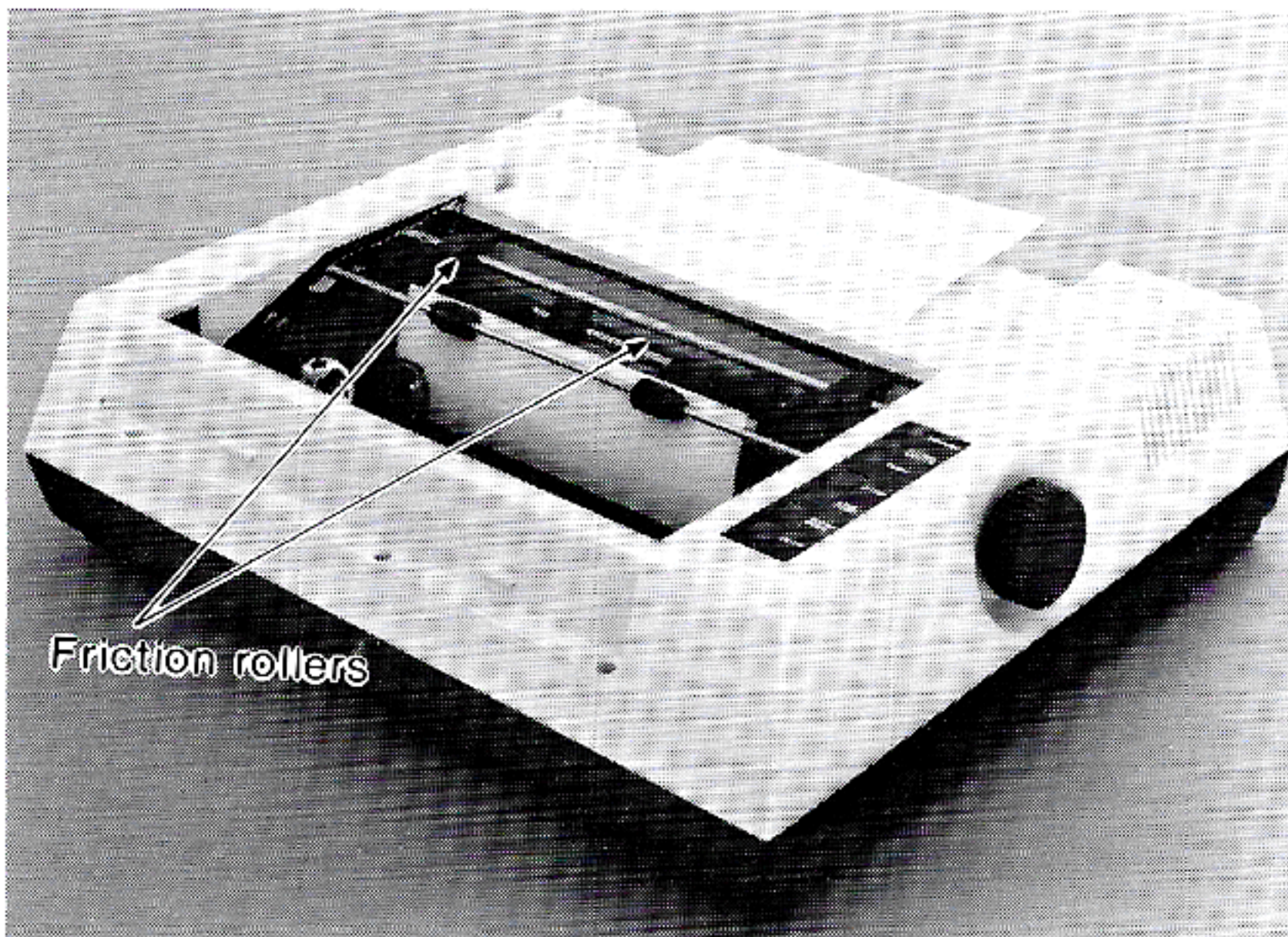

Figure 19

## 2. Single sheets of paper

Except for those involving the tractors, all of the operations are the same.

Note: 1. For proper friction feed, be sure that the friction rollers are positioned directly on top of the rubber tractor rings and that these two sets of rollers properly grasp the paper (figure 19).

2. The paper empty switch is located about 2¼" inside the left side of the printer case on the metal base plate. The left edge of the single sheet paper must cover the switch in order to avoid the PAPER EMPTY condition.



## Head Position Adjustment

The head adjustment lever is moved by pressing it toward the outside as it is moved back and forth. When adjusting, make sure that the foot of the lever is set in one of the click holes. The head is adjusted by moving the lever toward 8 for thick paper or multiple copies and toward 1 for single sheets of lightweight paper. The printer is shipped with the lever foot set to position 3, the ideal position for a single sheet.

The lever foot should be set to 8 for insertion and removal of the ribbon.

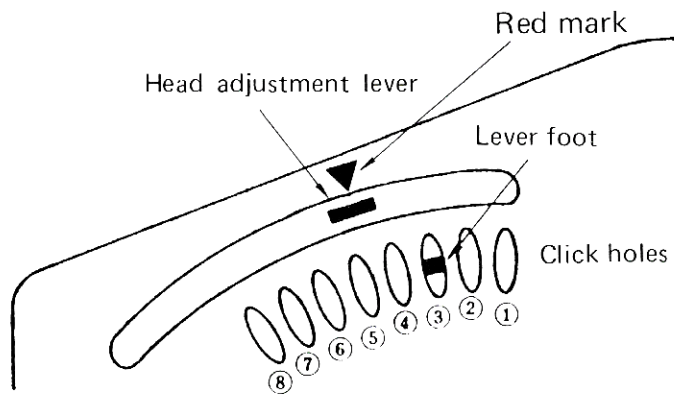

Figure 20

## Self Test Printing

1. To activate the Self Test, load paper into the printer with the printer turned off, then hold down the LINE FEED switch as you turn the printer power on. The printer will go through its normal initialization routines and proceed to print the test pattern in order of the ASCII code numbers stored inside.
2. Push the STOP switch to halt the self test.
3. Attempting to perform a self test with no paper in the printer will result in movement of the printhead, but no printing performed.
4. If self test does not function, check Dip Switch 2, assuring that it is turned on.

## Automatic Printing Function

If text data is input by the printer that exceeds the length of one line, the text starts printing even though a print command was not received. The portion of the text that exceeds the line length is printed on the next line.

If, however, graphics data (including repeated graphics printing) is input that exceeds the line length, that portion of the data exceeding the line is ignored. The mode is not changed in either case.

## Error Conditions

When the printer enters an error condition, the POWER lamp starts blinking and an ERROR signal is output to the computer. An error condition is cleared by either turning power off and then back on again, or by the input of an INITIAL signal from the computer. Apple or Franklin users may send an INITIAL signal from the computer with a CONTROL RESET. Depressing a CTRL ALT DEL on the IBM Personal Computer will clear the error condition. A printer error condition arises only when abnormal sensor timing is detected.

## Caring for Your Printer

- Wait at least 2 seconds after turning power off before turning it back on again. The initialization process may not be performed correctly if this is not done.
- The printer should not be used in high humidity, direct sunlight or dusty conditions.
- The operating temperature range is 41°F – 104°F. Rapid temperature changes should be avoided.
- Be sure that power is turned off to both the printer and computer before connecting or disconnecting the signal cable from the computer.
- Do not turn power off while the printer is printing.
- Regardless of whether the power is ON or OFF, do not try to move or apply undue force to the printhead. Also, do not touch any of the moving parts of the printer while it is in operation.
- Do not operate the printer without the ribbon cassette and paper properly installed. Failure to do so may cause damage to the printhead and/or platen.
- Be careful to insure that paper is being supplied properly to the printer. Be particularly careful when using multiple part forms. The paper should be placed as near to the printer as possible and at the same height as the printer. (With the printer on a table, avoid supplying paper from a lower level, like the floor.)
- Set the connector lock levers in place when attaching the input signal cable.
- Normal character pattern dot densities are the most desirable. Continuous printing of very high density patterns may affect the life of the printhead.
- As a general rule, the upper case of the printer should not be removed. If it must be removed (for example to set the dip switches), be sure to unplug the power cord from the outlet before doing so.

### Maintenance (Daily care)

This printer needs little or no daily maintenance. Like any other electrical equipment, keep your printer clean, dust-free and in good operating condition.



# Part 3

---

## Configuring Your Printer

Now that you have become familiar with the physical features of the Transtar 315, it is time to learn how to setup the printer for your particular computer.

The Transtar 315 will easily configure to most operating systems available for personal computers. If you will be printing color graphics, you must determine if your software supports the Transtar 315. The following is a guide to using the Transtar 315 with several popular computer systems for color graphics.

Apple II/IIe or Franklin users can easily use all of the features of the Transtar 315 with the optional PICS interface. This interface card allows the printing of color graphics by simply depressing the COPY button on the printer. A software graphics driver routine is available through your local dealer for non-PICS card use.

IBM Personal Computer users can print high and medium resolution and the special IBM character set with the available T315-PC DOS 1.10 driver program. This routine loads above DOS and activates the PrtSc key to print graphics. The software driver requires a color graphics board. Your dealer can provide you with a copy of the driver disk.



## Making a Cable

Most users will have purchased a cable designed for use with their printer and computer. The optional PICS interface is supplied with a cable and connector. The following information is supplied for persons interested in understanding or making their own cable.

The Transtar 315 should easily configure to most computers that support the standard Centronics parallel port. Input in the Input/Output column indicates an input signal into the printer. Output refers to the output from the printer.

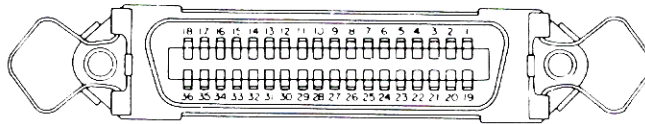

| PIN | SIGNAL         | IN/OUT | PIN | SIGNAL      | IN/OUT |
|-----|----------------|--------|-----|-------------|--------|
| 1   | STROBE         | IN     | 19  | GROUND      |        |
| 2   | DATA 1         | ”      | 20  | ”           |        |
| 3   | DATA 2         | ”      | 21  | ”           |        |
| 4   | DATA 3         | ”      | 22  | ”           |        |
| 5   | DATA 4         | ”      | 23  | ”           |        |
| 6   | DATA 5         | ”      | 24  | ”           |        |
| 7   | DATA 6         | ”      | 25  | ”           |        |
| 8   | DATA 7         | ”      | 26  | ”           |        |
| 9   | DATA 8         | ”      | 27  | ”           |        |
| 10  | ACK            | OUT    | 28  | ”           |        |
| 11  | BUSY           | ”      | 29  | ”           |        |
| 12  | PAPER EMPTY    | ”      | 30  | ”           |        |
| 13  | NC             |        | 31  | INITIAL     | IN     |
| 14  | GROUND         |        | 32  | ERROR       | OUT    |
| 15  | NC             |        | 33  | GROUND      |        |
| 16  | ”              |        | 34  | NC          |        |
| 17  | CHASSIS GROUND |        | 35  | COPY SWITCH | OUT    |
| 18  | NC             |        | 36  | NC          |        |

NC: No connection

### 2. Explanation of the input/output signals

a) Signals input to the printer.

- DATA 1            These are the eight lines that supply the 8-bit parallel data.
- DATA 2            “1” = HIGH
- DATA 3
- DATA 4
- DATA 5
- DATA 6
- DATA 7
- DATA 8
  
- $\overline{\text{STROBE}}$             This is the signal line used to strobe the eight bits of data into the printer. Data is strobed in when the line goes “LOW.”
  
- $\overline{\text{INITIAL}}$             This signal is used to set the printer to its initial state. This pin is normally “HIGH,” at “LOW,” the clearing sequence is executed to return it to the initial condition.

b) Signals output from the printer:

- BUSY            This signal indicates that the printer is BUSY. When “HIGH,” new data cannot be input.
  
- $\overline{\text{ACK}}$             This signal is always output at the very end of the BUSY signal. It can be used to indicate that the printer is requesting more data.  
 Note: The BUSY and  $\overline{\text{ACK}}$  signals are always output every time the printer inputs data.
  
- $\overline{\text{ERROR}}$             This signal goes “LOW” when the printer enters an error condition. In this case, the printer’s control circuitry shuts down. There are 2 ways to clear this condition:
  - 1) Turn the printer off for a few seconds and back on again.
  - 2) Input the  $\overline{\text{INITIAL}}$  signal.
  
- PAPER EMPTY            When the printer is out of paper, this signal goes “HIGH” and the printer stops processing data. Insert paper and push the STOP switch to clear this condition.
  
- $\overline{\text{COPY SWITCH}}$             This signal stays “LOW” while the copy switch is pressed. This switch is activated only with the optional PICS interface.

### 3. Electrical conditions

#### a) Signal levels

All input/output signals are TTL level.

“HIGH” level +2.4 5.0 [V] At the receiving pin

“LOW” level +0.0 0.4 [V] on printer side.

T = the value as shown on the timing chart.

$$T_f, T_r \leq 100 \text{ ns}$$

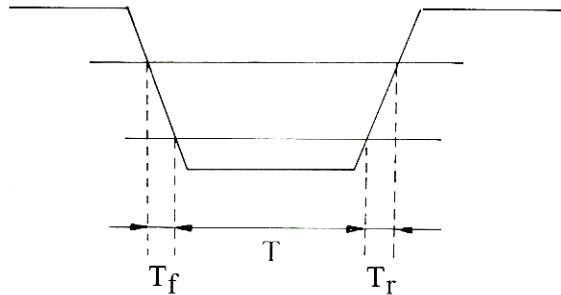

#### b) Input/output conditions

Except for the  $\overline{\text{STROBE}}$  and  $\overline{\text{INITIAL}}$  signals, all input/output lines are pulled up to +5.0 [V] with a 10K [ohm] resistor.

##### ▪ Input signals

The input loading is equivalent to a single 74LS04 gate input.

##### ▪ Output signals

The output is equivalent to the output of a single 74LS04 gate. The recommended load for the outputs is a single TTL or LSTTL input gate.

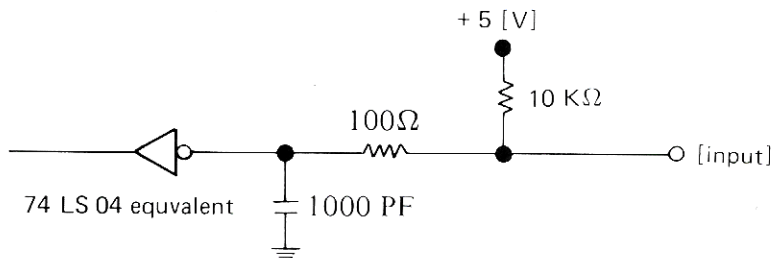

The  $\overline{\text{STROBE}}$  and  $\overline{\text{INITIAL}}$  signals are pulled up to +5.0 [V] with a 1000 ohm resistor. One hundred (100) ohms and 1000 PF are added to the  $\overline{\text{STROBE}}$  and  $\overline{\text{INITIAL}}$  signals only.

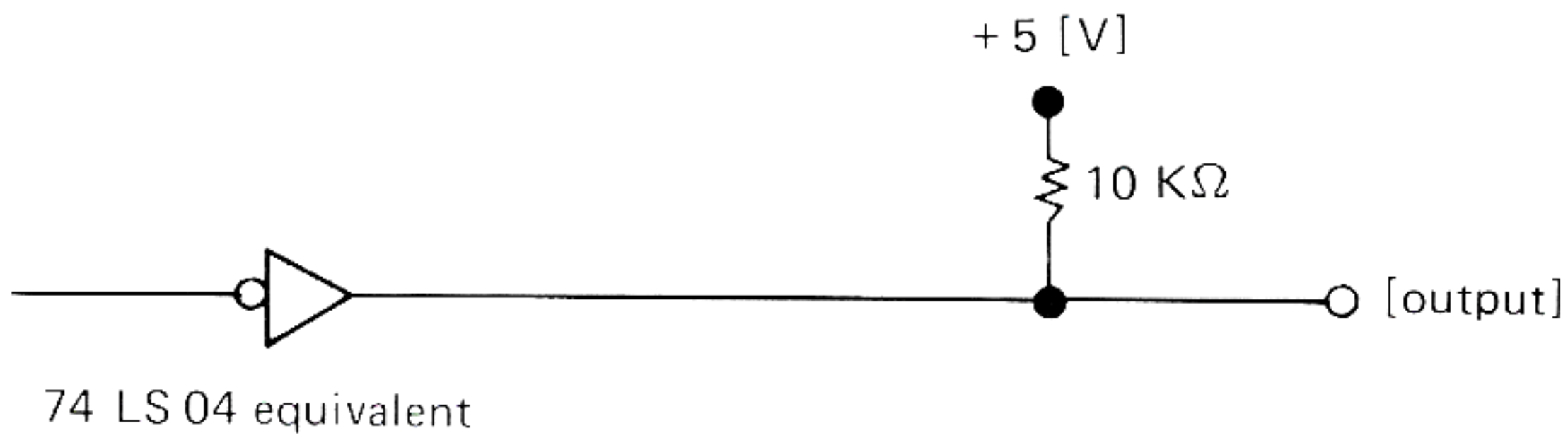

c) Signal cable length

The maximum length for the signal cable is 6½ feet. The following signals should be run as twisted pairs with the GND lines, or alternated with GND lines when flat cable is used.

STROBE, INITIAL, BUSY, ACK, ERROR

Timing chart

a) During data input

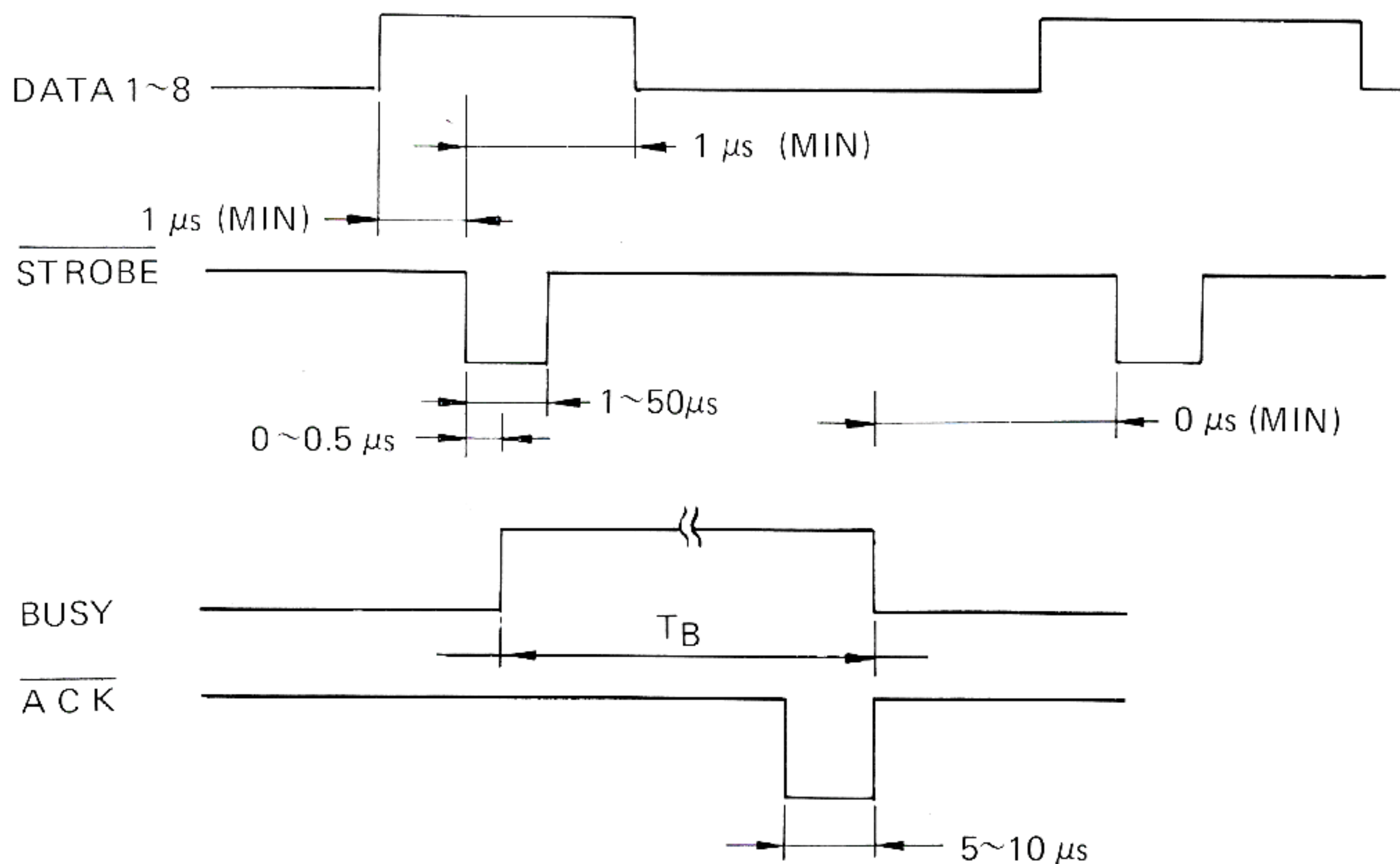

TB; character codes  
FF/CR/LF codes

50 μs or longer (varies with the data)  
printing + line feed and carriage return



## Dip Switch Settings on the Control Circuit Board

The dip switches, located on the main circuit board, are accessible by removing the upper case. To do so, remove six screws connecting the upper and lower cases, and slide the upper case off. Special care should be taken in gently removing the upper case, as it and the circuit board are connected with a cable.

| No. | Function                               | ON  | OFF                                       | Factory Setting |
|-----|--|---|---|-----------------|
| 1   | Selection of black and white on screen | Print black on screen as black on printer | Print black on screen as white on printer | OFF             |
| 2   | Self test printing                     | Activate printing                         | No printing                               | OFF             |
| 3   | CR code meaning                        | Carriage return and line feed             | Carriage return only                      | OFF             |
| 4   | Not used                               |   |   | OFF             |

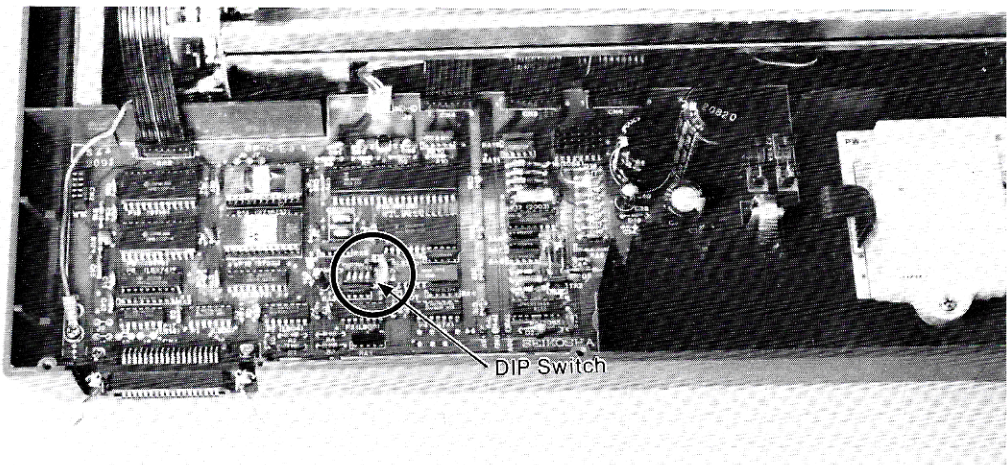

Figure 21 Control PCB

---

# Part 4

---

## Programming Your Printer

The Transtar 315 can perform color and graphics printing and many other special functions such as double width characters with the use of simple programming codes. In this section you will find examples (in MBASIC®) of how to program the printer for each of these functions. Each code is described followed by the Mbasic listing as you should type it and the resulting output as it will be printed on the paper. These examples will help you become acquainted with the printer's features and how to access them. The outline of the video screen displays what you should type on your keyboard. The resulting printer output follows below.



## Converting the Programs to Apple II/IIe Format

The MBASIC listings in this section can easily be converted to run on the Apple II or IIe personal computers. The following changes need to be made in each example:

- 1) Add line 1 to read: ]PR #1
- 2) Add line 1000 to read: ]PR #0
- 3) Change all lines that read LPRINT to PRINT

Example:

```
10 REM REPEATED GRAPHICS PRINTING
20 REM PRINT DECIMAL (75)- 70 TIMES
30 LPRINT:LPRINT:LPRINT
40 LPRINT CHR$(28);CHR$(70);CHR$(75)
```

Before

```
1 PR#1
10 REM REPEATED GRAPHICS PRINTING
20 REM PRINT DECIMAL (75)- 70 TIMES
30 PRINT:PRINT:PRINT
40 PRINT CHR$(28);CHR$(70);CHR$(75)
1000 PR#0
```

After

## Programming Code Summary

| Code          | Function   |
|---------------|--|
| CR            | Print buffer and execute a Carriage Return and Line Feed (depending on setting Dip Switch 3).  |
| LF            | Print buffer and execute a Carriage Return and Line Feed.  |
| FF            | Print buffer and execute a Form Feed to the pre-defined page length set by an ESC Z n or ESC Z 0 n.  |
| SO            | Turn on Double Width Print.  |
| SI            | Turn off Double Width print and return to normal print.  |
| CAN           | Clear buffer.  |
| ESC T n1 n0   | Set line feed spacing in n1n0/120th increments. n1n0 is a number equal-to or between 0 but equal to but not greater than 99.                 |
| ESC A         | Set line feed spacing to 6 lines per inch.   |
| ESC B         | Set line feed spacing to 8 lines per inch.   |
| POS n2 n1 n0  | Specifies print position by character location. This three-digit decimal number is equal-to or greater-than 0 but less-than or equal-to 105. |
| ESC POS nH NL | Specifies print position in dot units. This two byte hexadecimal number must be equal-to or greater-than 0 but less-than or equal-to 639.    |
| ESC Z n       | Specifies page length by number of lines. The value of n is a hexadecimal number equal-to or greater-than 1 but less-than or equal-to 127.   |
| ESC Z (00)H n | Specifies page length by inches. The value of n is greater-than or equal-to 0 but less-than or equal-to 22.                                  |
| ESC N         | Specifies the 10 characters per inch font.   |
| ESC G         | Specifies 13.3 characters per inch printing.   |

| Code                      | Function  |
|---------------------------|---|
| ESC K n2n1n0<br>GD1...GDn | Specifies graphics data in the form of 8 vertical dot columns. n2n1n0 represents the number of vertical columns. Graphics Data (GD) is then input with the same number as sent in n2n1n0. |
| FS n GD                   | Prints graphics data repeatedly. n is equal-to or greater-than 0 but less-than or equal-to 255.   |
| ESC R CD                  | Specifies repeated printing of characters.  |
| DC4 n                     | Specifies color selection. This may be used in both graphics and text mode.   |
| ESC C<br>n2n1n0m2m1m0     | Specifies color for individual dots in the horizontal RGB raster scan graphics mode.  |
| ESC P<br>n2n1n0m2m1m0     | Specifies color for individual dots in the horizontal 'head hammer' raster scan graphics mode.  |
| ESC D                     | Specifies single-pass of graphics printing.   |
| ESC E                     | Specifies 2-pass color graphics printing. Effective for large color fill areas.   |

## Programming Codes

Following are detailed explanations of the programming codes that allow you to take advantage of all the features of your printer.



Input of this code causes the information in the printer's buffer to be printed. The execution of a line feed after printing is determined by the setting of switch number 3. The printer is shipped with the switch in the OFF position which means that no line feed is executed. (Refer to Part 3 on Dip Switch Settings for instructions on changing switches). If there is no data in the buffer, or if all of the data are spaces, the printhead does not move.

```
10 REM CARRIAGE RETURN EXAMPLE
20 LPRINT:LPRINT:LPRINT
30 LPRINT "THIS IS A SAMPLE LINE.";
40 LPRINT CHR$(13);
50 LPRINT "WITHOUT LINE 40 THIS WOULD
    BE ON THE SAME LINE AS ABOVE."
```

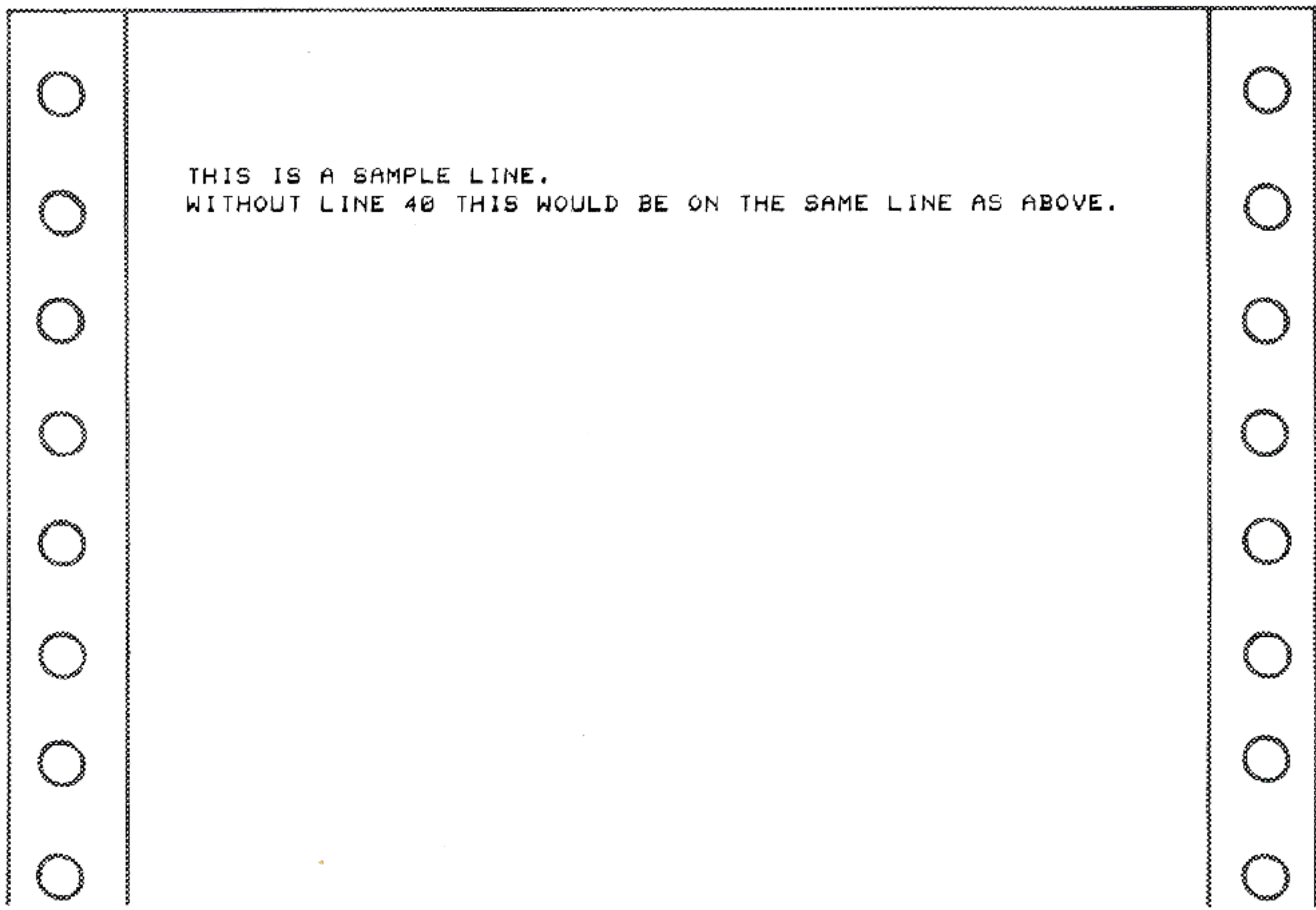

Input of this code causes the data in the printer's buffer to be printed, then a line feed and carriage return executed. If there is no data in the buffer, or if all of the data are spaces, a line feed alone is executed. The line feed spacing is set by any of the following commands:

ESC T n1 n0    ESC A    ESC B

```
10 REM LINE FEED EXAMPLE
20 LPRINT:LPRINT:LPRINT
30 LPRINT "HERE IS THE LINE FEED EXAMPLE.";
40 LPRINT CHR$(10);:REM LINE FEED COMMAND
50 LPRINT "TEXT AFTER A LINE FEED."
```

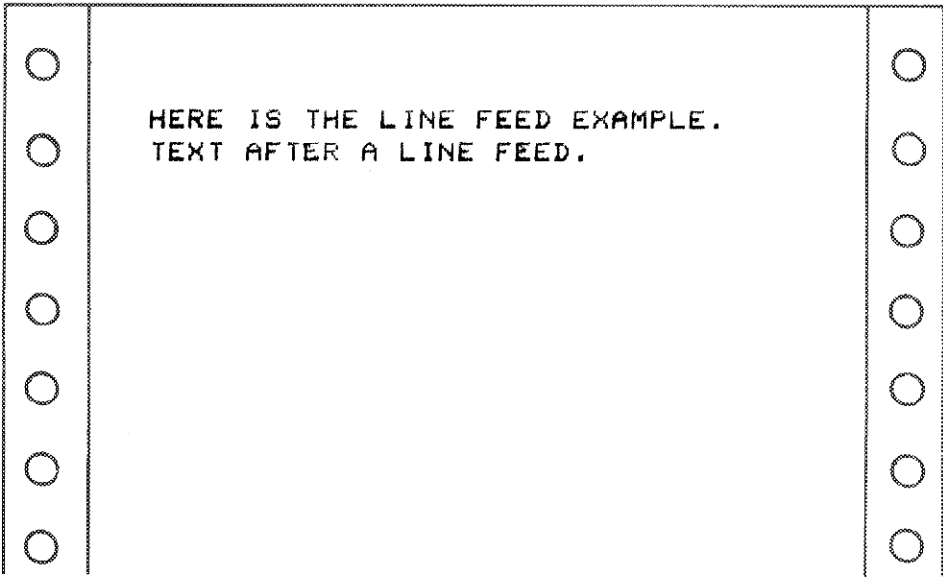

Input of this code causes the data in the printer's buffer to be printed and a form feed executed. The length of the form feed is the preset page length. When the power is turned on, or when an INITIAL signal is input, the page length is set to eleven inches (66 lines). If there is no data in the buffer, or if all of the data are spaces, a form feed alone is executed. The page length can be changed by:

ESC Z n            ESC Z 0 n

```
10 REM FORM-FEED EXAMPLE
20 LPRINT "PAGE 1 -----"
30 LPRINT CHR$(12):REM SEND FORM FEED
40 LPRINT "PAGE 2 -----"
```

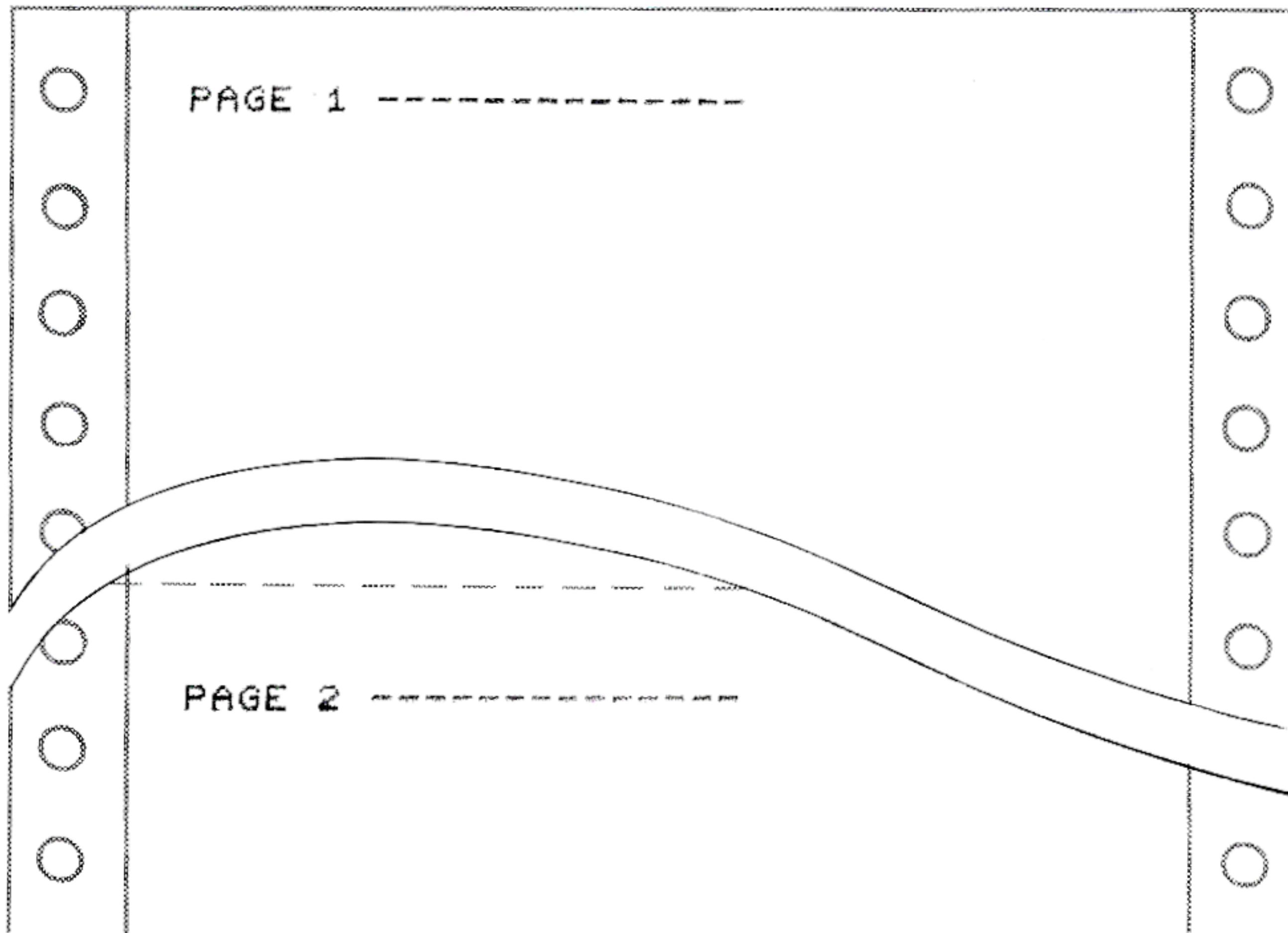



## Double Width Printing

SO (ON) (0E) Hex (14) Decimal  
SI (OFF) (0F) Hex (15) Decimal

After input of the SO code, the characters that follow are printed in the double width format. This code may be input at any position and remains in effect until the input of an SI code or power off of the printer. The SI code is used to clear double width printing and return to standard width print. When the power is turned on or when an INITIAL signal is sent from the computer, the printer is set to the standard width print format (SI).

```
10 REM DOUBLE WIDTH PRINT EXAMPLE
20 LPRINT:LPRINT:LPRINT
30 LPRINT "NORMAL WIDTH ";
40 LPRINT CHR$(14);:REM TURN ON
   DOUBLE WIDTH PRINT
50 LPRINT "DOUBLE WIDTH ";
60 LPRINT CHR$(15);:REM TURN OFF
   DOUBLE WIDTH PRINT
70 LPRINT "NORMAL PRINT AGAIN!"
```



NORMAL WIDTH DOUBLE WIDTH NORMAL PRINT AGAIN!

Data that is entered into the buffer prior to the input of the CAN code is cleared. However, the printer mode is not cleared.

```
10 REM CLEAR BUFFER EXAMPLE
20 LPRINT "THIS IS BEING INPUT TO THE
    BUFFER";
30 LPRINT CHR$(24):REM SEND CAN CODE
40 LPRINT "THIS IS PRINTED AFTER
    THE CLEAR BUFFER CODE."
```

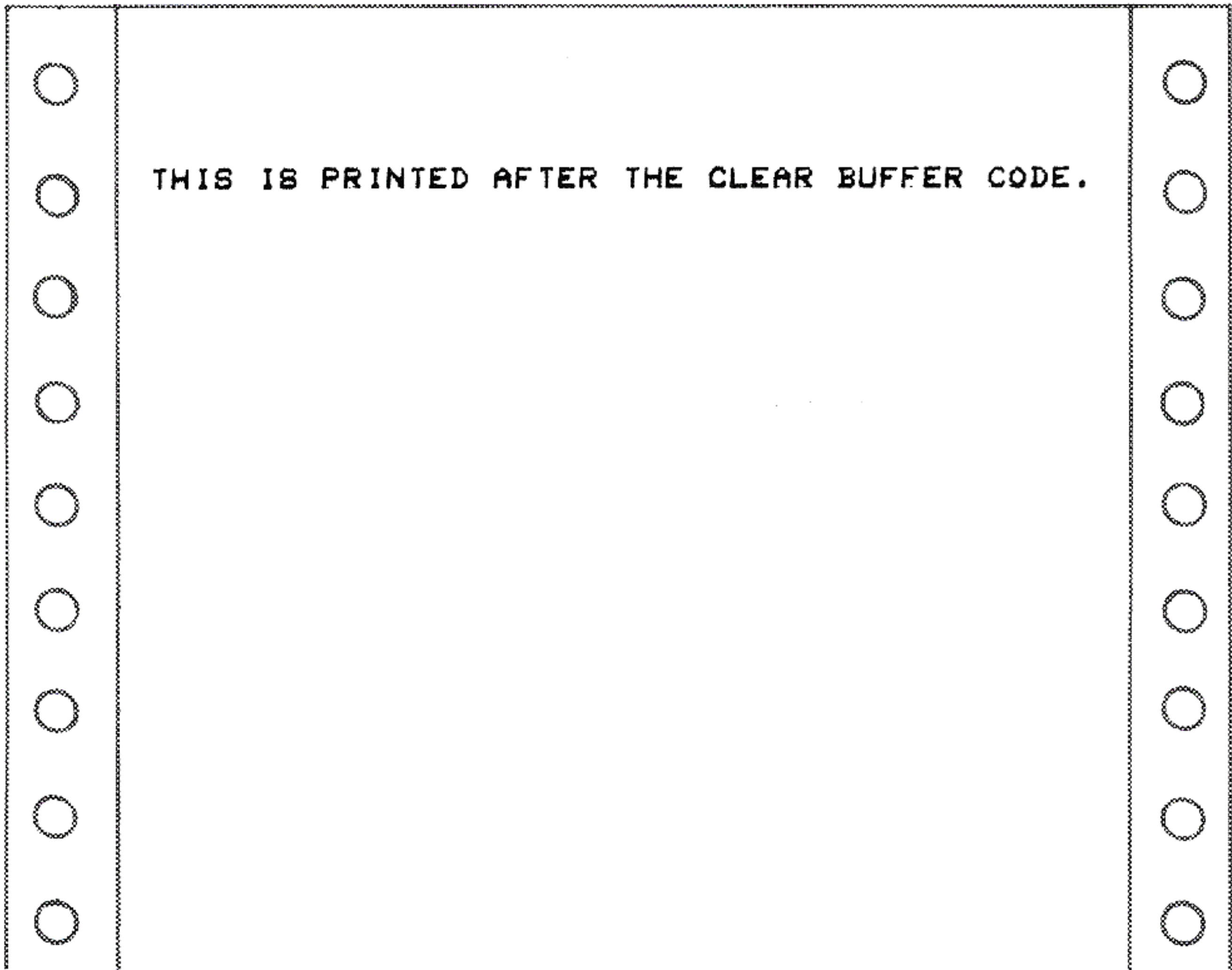



n1n0 are ASCII codes for a two-digit decimal number greater-than or equal-to 0 but less-than or equal-to 99. The amount of movement for a line feed is set to n1n0/120 inch increments. All line feed commands that are executed thereafter will move the paper in accordance with this setting. For n1n0 = 12, the 8th dot (bottom dot) of a row just connects with the first dot (top dot) of the lower row. This is especially useful in the graphics mode since the patterns then appear continuous. The line feed spacing remains unchanged until the input of another line feed spacing command such as:

ESC A

ESC B

```

10 REM VARIABLE LINE SPACING
20 FOR N=1 TO 10
30 IF N<10 THEN N$="0"+STR$(N):GOTO 50
40 N$=STR$(N)
50 LPRINT CHR$(27)+"T"+N$
60 LPRINT "VARIABLE LINE SPACING"
70 NEXT N
    
```

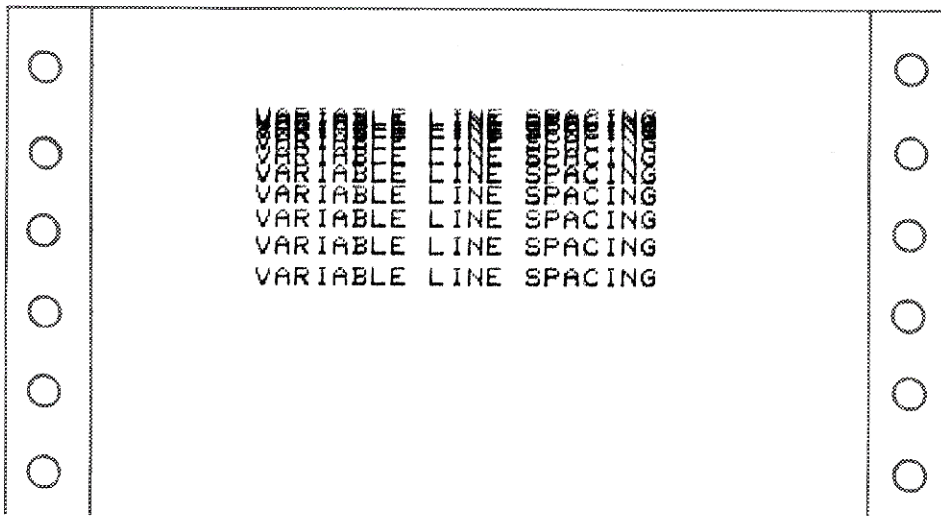

This command causes the line feed spacing to be set to six lines per inch. When the power is turned on or when an INITIAL signal is input, the line feed spacing is automatically set to 1/6 inch. The setting remains unchanged until the input of another line feed spacing command such as:

ESC B

ESC T n1n0

```
10 REM 1/6 LINES PER INCH SPACING
20 LPRINT CHR$(27);CHR$(65):REM SET
   1/6TH LINES PER INCH
30 FOR K=1 TO 3
40 LPRINT "6 LINES PER INCH SPACING"
50 NEXT K
```

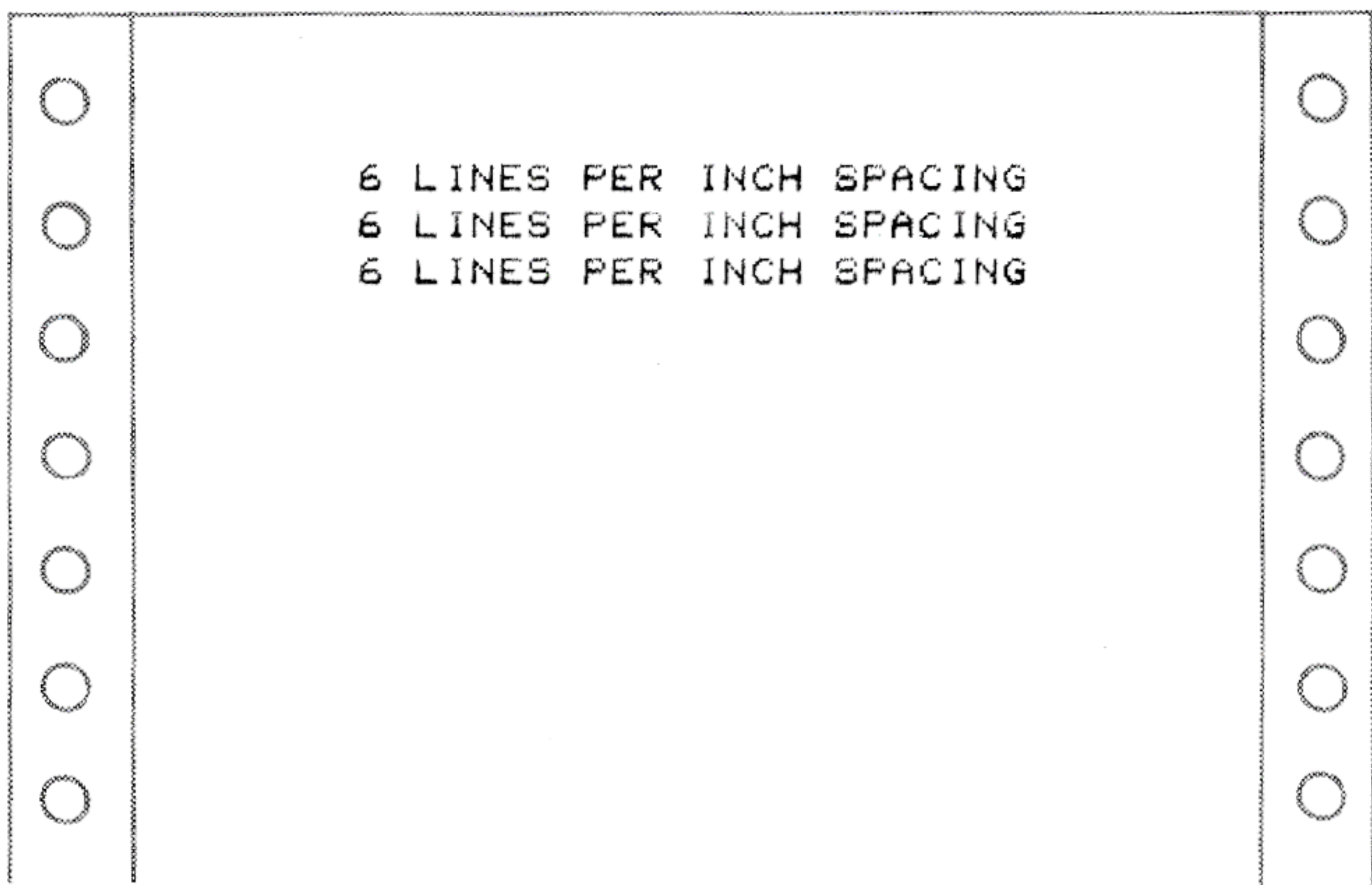



This command causes the line feed spacing to be set to eight lines per inch. The setting remains unchanged until the input of another line feed spacing command such as:

ESC A

ESC T n1n0

```
10 REM 1/8 LINES PER INCH SPACING
20 LPRINT CHR$(27);CHR$(66):REM SET
   1/8TH LINES PER INCH
30 FOR K=1 TO 3
40 LPRINT "8 LINES PER INCH SPACING"
50 NEXT K
```

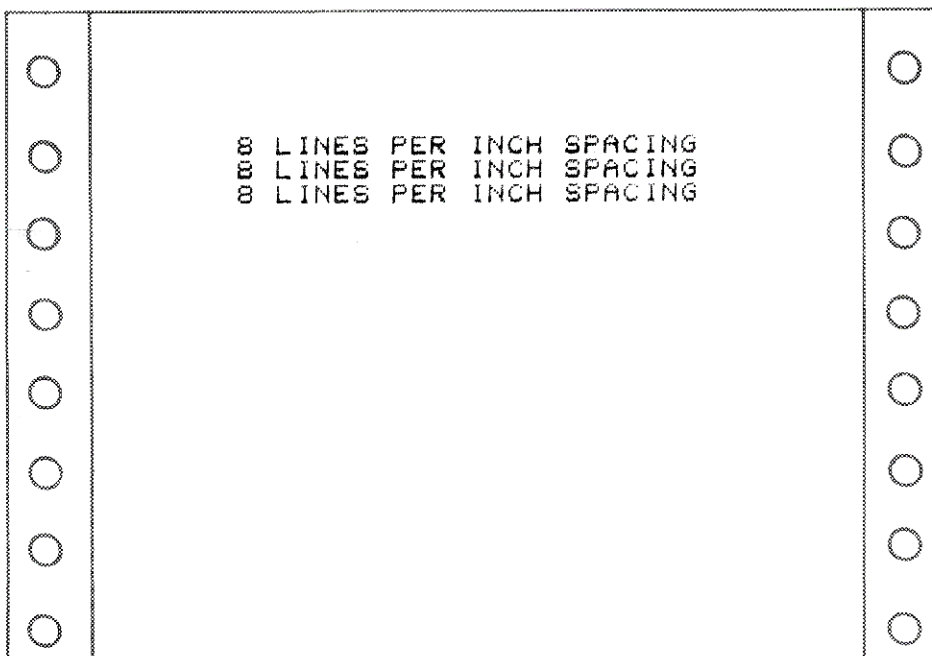

## Specifying Print Position by Character

POS n2n1n0 (10)n2n1n0 Hex  
(16)n2n1n0 Decimal

n2n1n0 is an ASCII code for a three-digit decimal number greater-than or equal to 0 but less-than or equal-to 105. Input of this code causes printing to start at the character column specified by n2n1n0 away from the home or starting left column position (n2n1n0 = 000). The 80th character position is n2n1n0 = 079. This specification can be made in either text or graphics mode. In double width printing mode, n2n1n0 is still calculated to be the number of standard size character spaces.

```
10 REM CHARACTER POSITION EXAMPLE
20 LPRINT "1";
30 LPRINT CHR$(16)+"020";:REM MOVE TO THE
    20TH POSITION
40 LPRINT "20";
50 LPRINT CHR$(16)+"040";:REM MOVE TO THE
    40TH POSITION
60 LPRINT "40";
70 LPRINT CHR$(16)+"041";:REM MOVE TO THE
    41ST POSITION
80 LPRINT "+1"
```

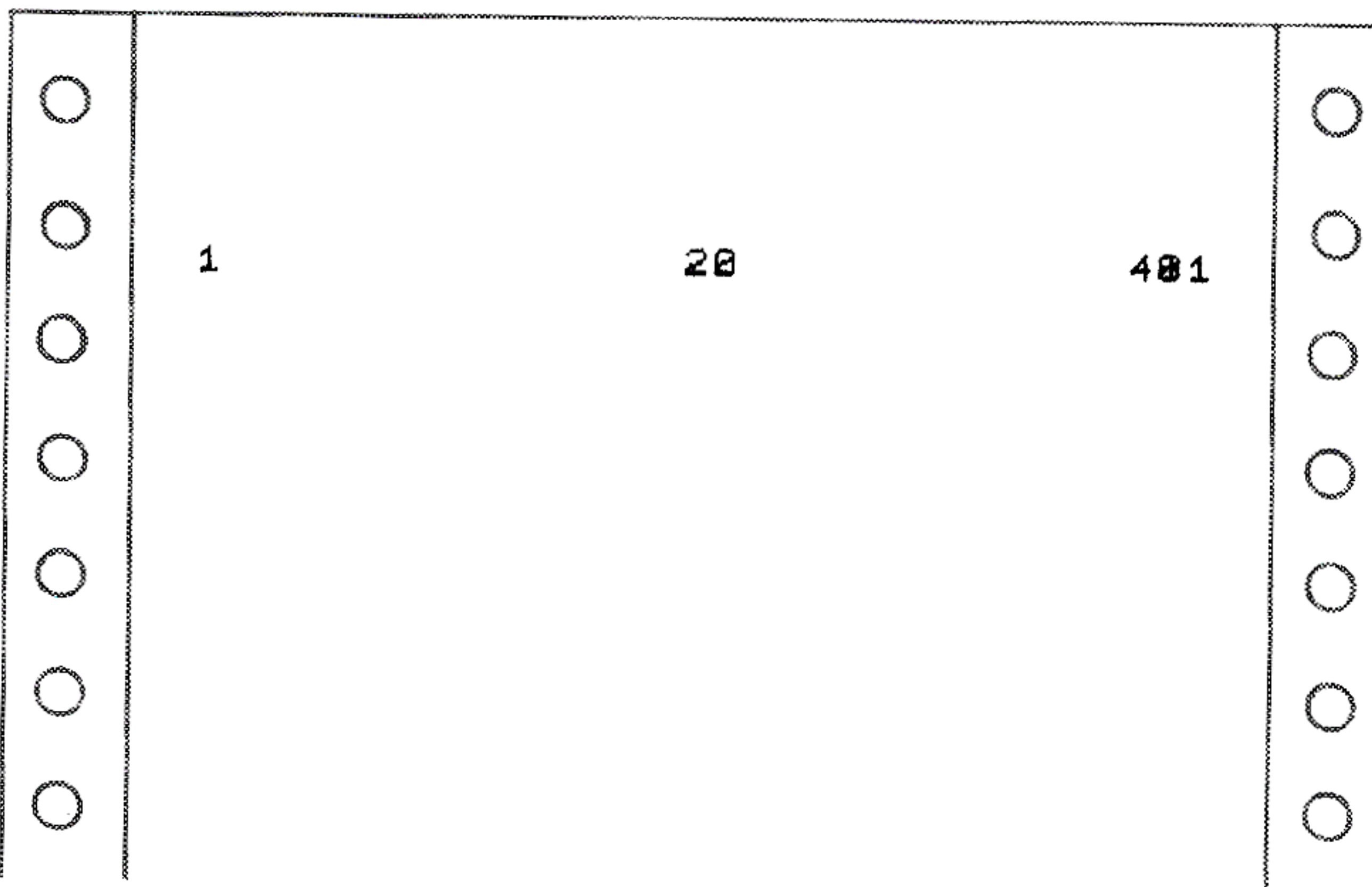



**Specifying Print Position by Dot Column** ESC POS nHnL (1B)(10)nHnL Hex  
(27)(16)nHnL Decimal

nHnL are 2 byte hexadecimal numbers between 0 and 639. nHnL is used to specify the dot position from which printing starts. With this command it is possible to specify in dot units exactly where printing is to begin within a line.

|             |                    |       |         |    |    |    |    |     |    |
|-------------|--------------------|-------|---------|----|----|----|----|-----|----|
| 1st byte nH | 0                  | 0     | 0       | 0  | 0  | 0  | 0  | P10 | P9 |
|             | P8                 | P7    | P6      | P5 | P4 | P3 | P2 | P1  |    |
|             |                    |       |         |    |    |    |    | nH  | nL |
| Example:    | 16th dot position  | (0)10 | ( 15)10 |    |    |    |    |     |    |
|             | 401st dot position | (1)10 | (144)10 |    |    |    |    |     |    |
|             | 601st dot position | (2)10 | ( 88)10 |    |    |    |    |     |    |

The specification of printing position can be performed as many times as desired. However, if a position is specified that already has data there, the resultant output will be as though two characters or graphics patterns were printed one on top of the other.

```

10 REM POSITION BY DOT COLUMN
20 LPRINT "1";
30 LPRINT CHR$(27)+CHR$(16)+CHR$(0)+CHR$(15);:
   REM MOVE TO THE 16TH DOT POSITION
40 LPRINT "16";
50 LPRINT CHR$(27)+CHR$(16)+CHR$(1)+CHR$(144);:
   REM MOVE TO THE 401ST POSITION
60 LPRINT "401";
70 LPRINT CHR$(27)+CHR$(16)+CHR$(2)+CHR$(88);:
   REM MOVE TO THE 601ST POSITION
80 LPRINT "601"

```

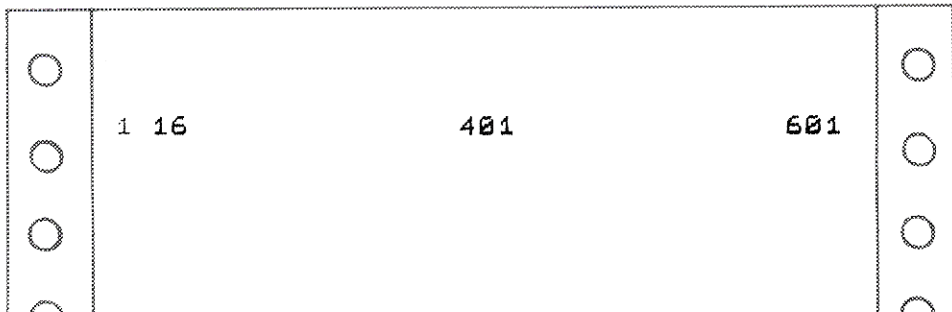

**Specifying Page Length by Number of Lines** ESC Z n (1B) (5A) (n) Hex  
(27) (90) (n) Decimal

---

This command is used to set the length of a page to the number of lines specified by the value of n. N is a hexadecimal number equal-to or greater than 1, but less-than or equal-to 127. The spacing for one line is 1/6 inch. Therefore, n = 6 will set the page length to 1 inch (1/6 x 6 = 1 inch). The top of page one is redefined as the paper position when this code is input. The page length counting begins there and is done by lines.

```
10 REM PAGE LENGTH BY LINES
20 REM SET 12 LINES
30 LPRINT CHR$(27)+"Z"+CHR$(12):REM
   SET TO 12 LINES
40 LPRINT "TOP OF PAGE ONE"
50 LPRINT CHR$(12):REM SEND FORM FEED
60 LPRINT "TOP OF PAGE TWO"
```

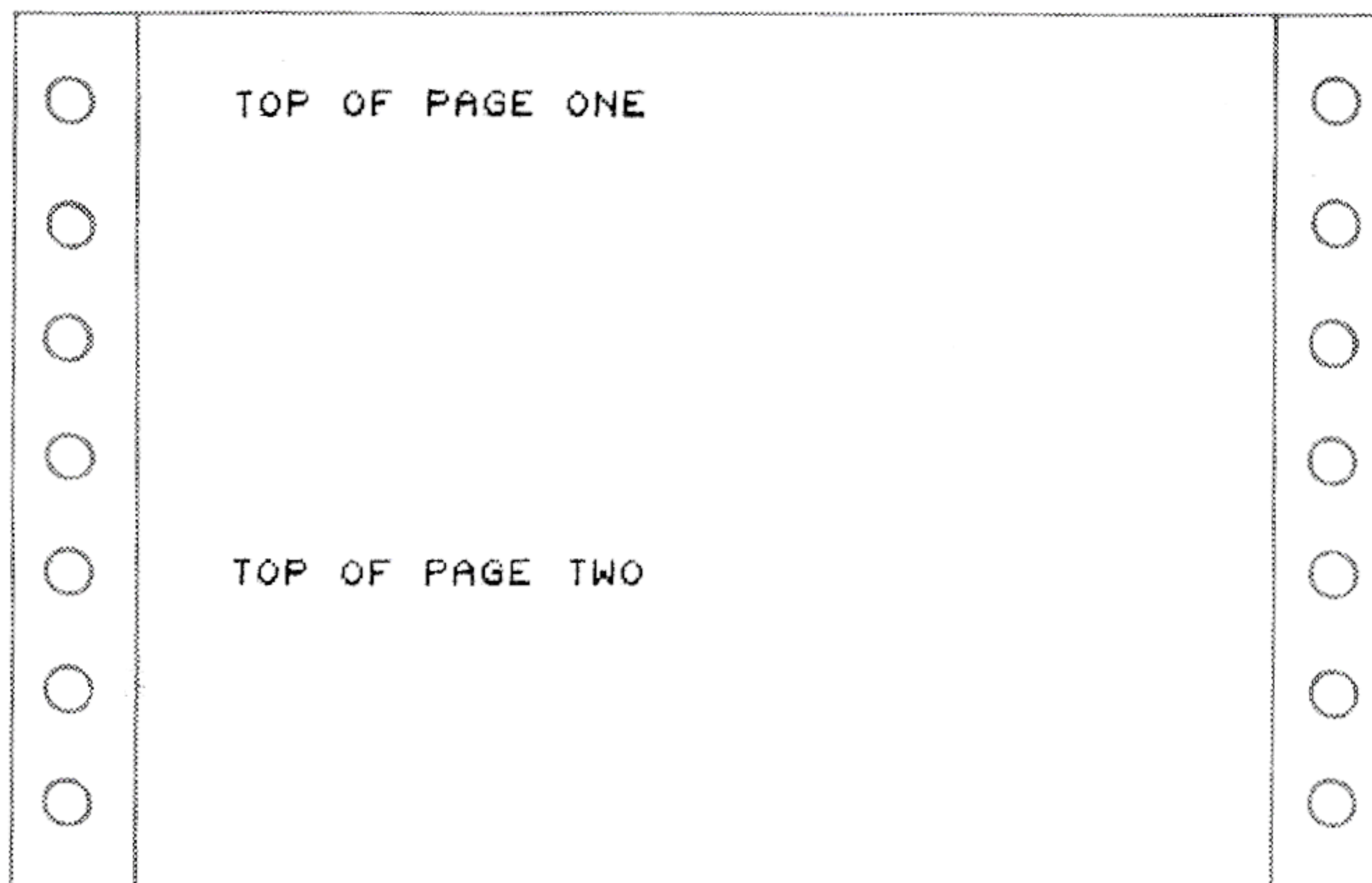



## Setting Page Length in Inches

ESC Z (00) (n) (1B)(5A)(00)(n) Hex  
(27)(90)(00)(n) Decimal

This command is used to set the length of a page to the number of inches as specified by n. N is a hexadecimal number equal-to or greater-than 0, but less-than or equal-to 22. If the setting is 0 or greater than 22, the result is as if 22 were set. The top of page one is redefined as the paper position when this code is input. The page length counting begins there and is done by inches. On power on of the printer, eleven inch paper is assumed.

```
10 REM SET PAGE LENGTH IN INCHES
20 LPRINT CHR$(27)+"Z"+CHR$(00)+CHR$(3):
   REM SET LENGTH TO 3-INCHES
30 LPRINT "TOP OF PAGE ONE"
40 LPRINT CHR$(12):REM SEND FORM-FEED
50 LPRINT "TOP OF PAGE TWO"
```

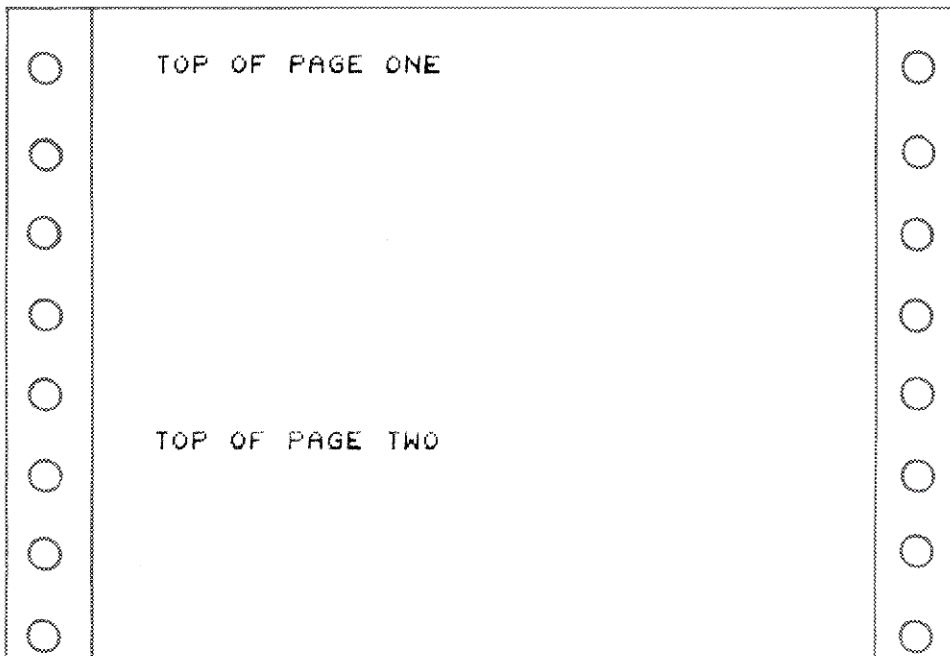

Entering this code selects printing at 10 characters per inch. When the power is turned on or when the computer sends an INITIAL signal, this print size is selected. This size may be combined with SI and SO for double width printing. This print mode is cleared with an ESC G.

```
10 REM 10 CHARACTERS PER INCH PRINT
20 LPRINT CHR$(27);CHR$(78)
30 LPRINT "10 CHARACTERS PER INCH"
```

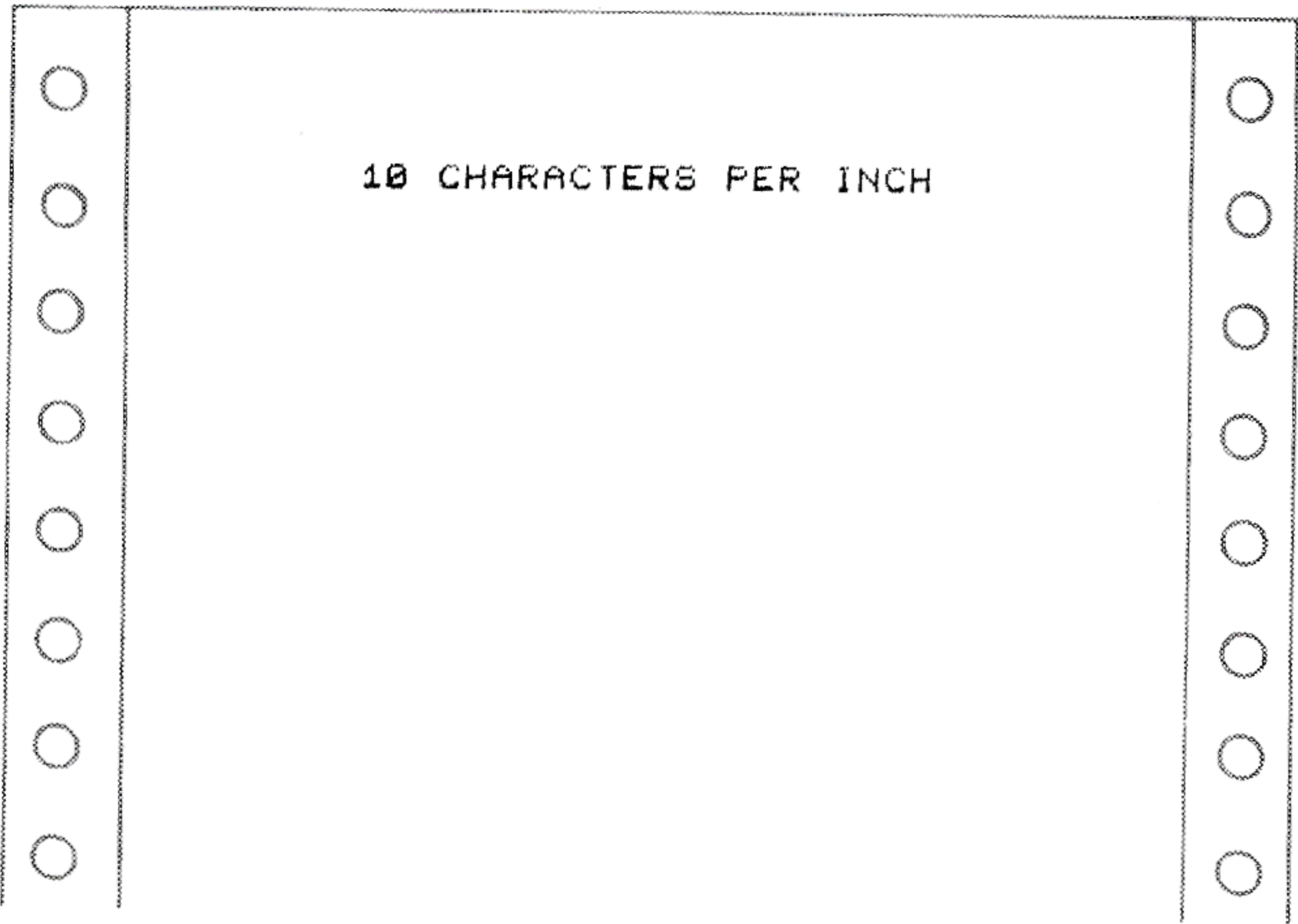



Input of this code selects printing in the 13.3 characters per inch mode. This is ideal for use with business spreadsheet programs requiring more printing columns. This mode can be used with SI and SO for double width printing. Clearing of this mode is accomplished with an ESC N code or by turning the printer off.

```
10 REM 13.3 CHARACTERS PER INCH
20 LPRINT CHR$(27);CHR$(71)
30 LPRINT "13.3 CHARACTERS PER INCH"
40 LPRINT CHR$(27);CHR$(78):REM
   BACK TO 10 CHARACTERS PER INCH
50 LPRINT "NOW BACK TO 10 CPI."
```

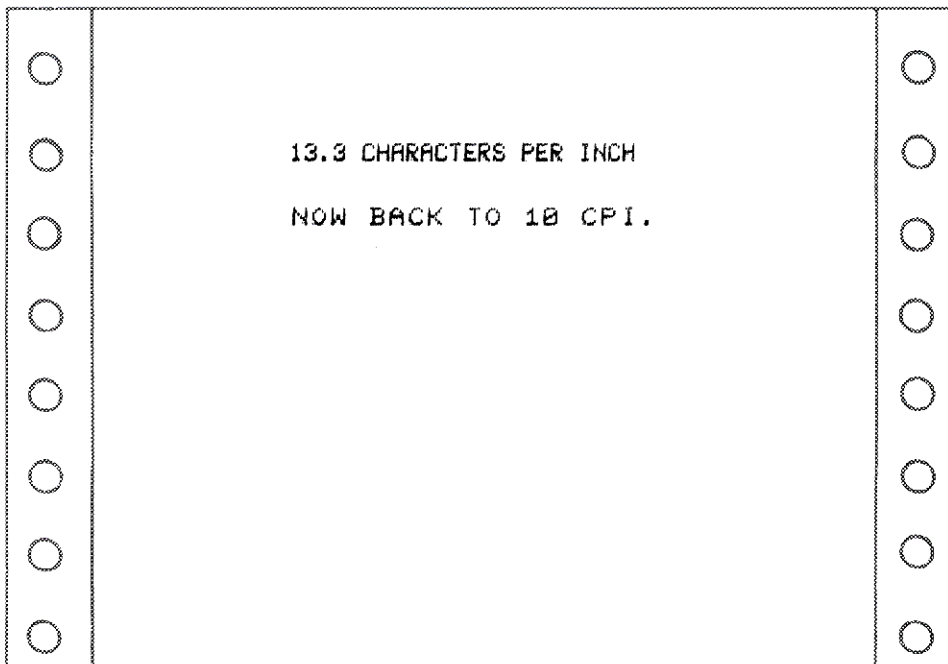

Forming a graphics pattern on the printer requires dots to be individually addressed. On a single pass of the printhead, eight dot rows may be printed, giving you complete control of which dots are printed or ignored. You may print eighty dots per inch horizontally across the page. The graphics resolution is 80 dots vertical by 80 dots horizontal.

ESC K specified the graphics mode. All input of graphics data will be in the form of 8-dot vertical columns. n2n1n0 are ASCII codes for a decimal number representing the number of vertical columns to be input. GD1...GDn are the same number of graphics data as represented by n2n1n0. n2n1n0 is a three digit decimal number equal-to or greater than 1, but less-than or equal-to 640. If n2n1n0 is 0, the command string ESC K n2n1n0 are ignored. The correspondence between graphics data and the dots printed is that the uppermost dot, dot 1, is represented by the lowermost bit, D1, and the lowermost dot, dot 8, is represented by the uppermost bit, D8.

|          |     |   |         |    |  |  |  |    |    |    |    |    |    |    |    |
|----------|-----|---|---------|----|--|--|--|----|----|----|----|----|----|----|----|
| Example: | 1   | ● | 1st dot |    |  |  |  |    |    |    |    |    |    |    |    |
|          | 2   | ● | 2nd dot |    |  |  |  |    |    |    |    |    |    |    |    |
|          | 4   | o | 3rd dot |    |  |  |  | D8 | D7 | D6 | D5 | D4 | D3 | D2 | D1 |
|          | 8   | ● | 4th dot | or |  |  |  | 0  | 1  | 0  | 0  | 1  | 0  | 1  | 1  |
|          | 16  | o | 5th dot |    |  |  |  |    |    |    |    |    |    |    |    |
|          | 32  | o | 6th dot |    |  |  |  |    |    |    |    |    |    |    |    |
|          | 64  | ● | 7th dot |    |  |  |  |    |    |    |    |    |    |    |    |
|          | 128 | o | 8th dot |    |  |  |  |    |    |    |    |    |    |    |    |

Looking at the ASCII Code Table, Appendix B, find the first four bits in the upper bit column. You will find that (0100) is in column 4. The last four bits, (1011), are located in row B or the lower bit chart. These meet at letter K or decimal 75 or hex 4B.

This data can now be programmed to print one column of graphics data:

| Upper Bit | Hex. | 0      | 1    | 2    | 3    | 4    | 5    | 6    | 7    | 8    |      |
|-----------|------|--------|------|------|------|------|------|------|------|------|------|
| Lower Bit | Hex. | Binary | 0000 | 0001 | 0010 | 0011 | 0100 | 0101 | 0110 | 0111 | 1000 |
| 0         | 0000 |        | 0    | POS  | SP   | 0    | (a   | P    | *    | p    |      |
|           |      |        | 0    | 16   | 32   | 48   | 64   | 80   |      |      |      |
|           |      |        |      | !    | 1    | A    |      |      | 104  | 120  | 13   |
| 9         | 1001 |        | 9    | 25   | 41   | 57   | 73   | 89   | 105  | 121  | 13   |
| A         | 1010 | LF     | 10   | 26   | 42   | 58   | 74   | 90   | 106  | 122  | 13   |
| B         | 1011 |        | ESC  | +    | :    | K    |      | k    | {    | }    | 13   |
|           |      |        | 11   | 27   | 43   | 59   | 75   | 91   | 107  | 123  | 13   |
| C         | 1100 | FF     | FS   | .    | <    | L    |      | l    | !'   | '!   | 14   |
|           |      |        | 12   | 28   | 44   | 60   | 76   | 92   | 108  | 124  | 14   |
| D         | 1101 | CR     |      | =    | M    |      |      | m    | }    | }    | 14   |
|           |      |        | 13   | 29   | 45   | 61   | 77   | 93   | 109  | 125  | 14   |
| E         | 1110 | SO     |      | >    | N    |      |      | n    | ~    | ~    | 14   |
|           |      |        | 14   | 30   | 46   | 62   | 78   | 94   | 110  | 126  | 14   |
| F         | 1111 | SI     |      | /    | ?    | O    |      | o    | SP   |      | 14   |
|           |      |        | 15   | 31   | 47   | 63   | 79   | 95   | 111  | 127  | 14   |



Dot Graphics Example

---

```
10 REM EXAMPLE GRAPHICS
20 LPRINT CHR$(27)+"K001"+CHR$(75)
30 LPRINT
```

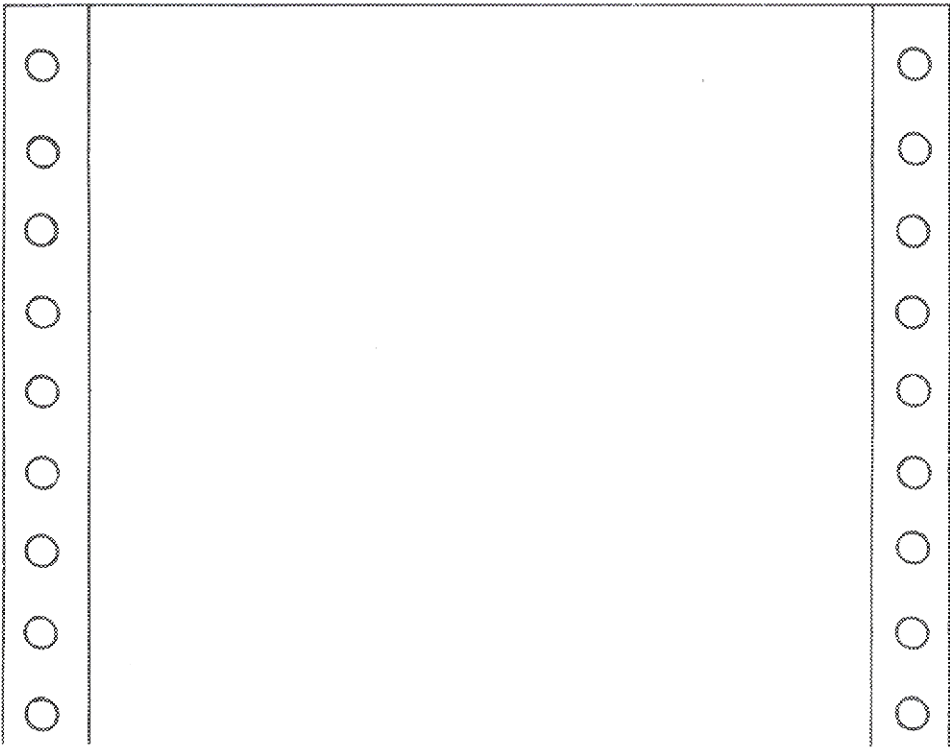

**Repeated Printing of Graphics Data** FS n GD (1C)(n)(GD) Hex  
(28)(n)(GD) Decimal

---

This command is used to specify repeated printing of a single byte of graphics data. n specifies the number of times the graphics data is to be printed when n is equal-to or greater than 0, but less-than or equal-to 255. Using the same graphics data you created in the Dot Graphics section, the example below will illustrate how to print the graphics data 70 times.

```
10 REM REPEATED GRAPHICS PRINTING  
20 LPRINT CHR$(28);CHR$(70);CHR$(75)
```

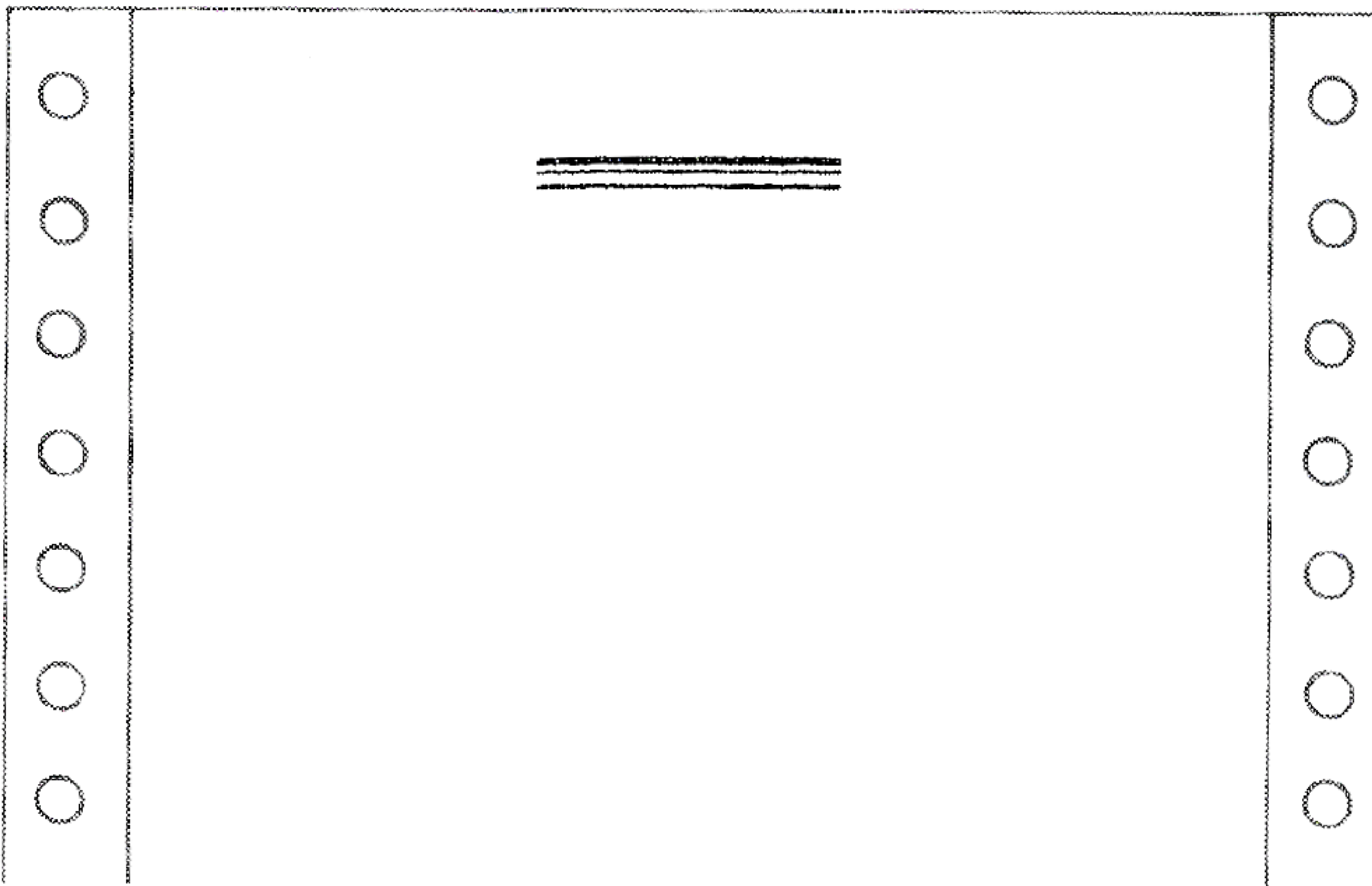



## Selecting Colors

DC4 n

(14)(n) Hex

(20)(n) Decimal

This code is used to specify the color for both text and graphics. The value of n is used to select one of seven colors. The color will not change until the next DC4 n is input or the power is turned off then on again, or an INITIAL signal is input from the computer.

- n = 0 Black
- n = 1 Magenta (pink)
- n = 2 Red
- n = 3 Purple
- n = 4 Green
- n = 5 Cyan (light blue)
- n = 6 Yellow

```
10 REM COLOR IN TEXT EXAMPLE
20 LPRINT CHR$(20);CHR$(0):REM BLACK
30 LPRINT "THIS IS BLACK"
40 LPRINT CHR$(20);CHR$(1):REM MAGENTA
50 LPRINT "HERE IS MAGENTA"
60 LPRINT CHR$(20);CHR$(2):REM RED
70 LPRINT "HOW ABOUT RED"
80 LPRINT CHR$(20);CHR$(3):REM PURPLE
90 LPRINT "PURPLE"
100 LPRINT CHR$(20);CHR$(4):REM GREEN
110 LPRINT "MY LAWN IS GREEN"
120 LPRINT CHR$(20);CHR$(5):REM CYAN
130 LPRINT "THE SKY IS BLUE"
140 LPRINT CHR$(20);CHR$(6):REM YELLOW
150 LPRINT "THE BANANA IS YELLOW"
```



An actual sample of this program would produce the colors noted.

This command is used to specify the repeated printing of a single character. n specifies the number of times the character is to be printed where n is equal-to or greater-than 0, but less-than or equal-to 255. If n = 0, the character is printed 256 times.

```
10 REM REPEATED CHARACTER PRINTING  
20 LPRINT CHR$(27)+CHR$(82)+CHR$(8)+"A"
```

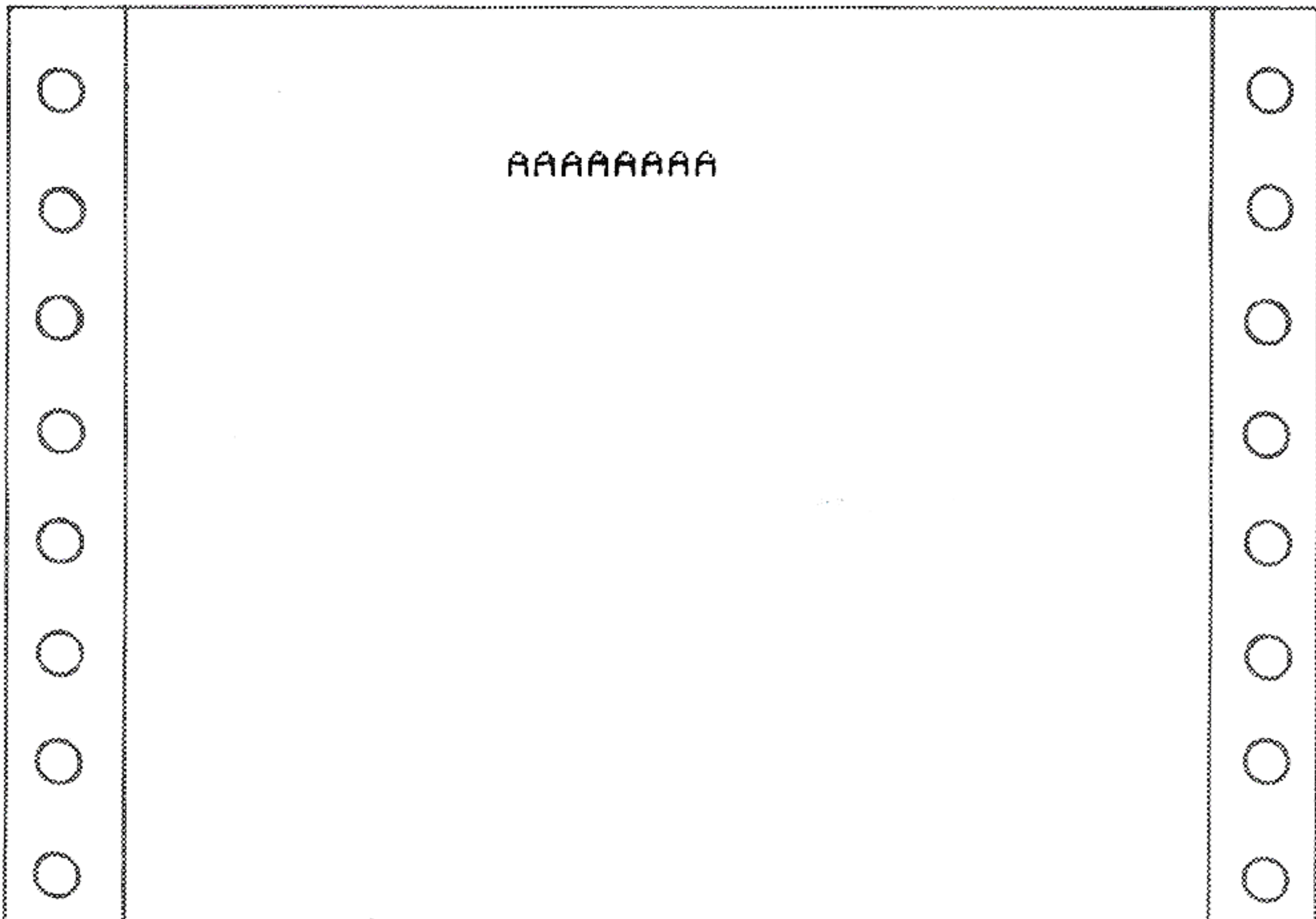



**RGB Raster Scan Graphics Mode** ESC C n2n1n0 m2m1m0 data  
 (1B)(43) n2n1n0 m2m1m0 data Hex  
 (27)(67) n2n1n0 m2m1m0 data Decimal

One means of input (RGB correspondence) allows the color for each dot to be individually specified in a raster scan type of horizontal sweep that is similar to the way a television screen is scanned from the upper left to the lower right.

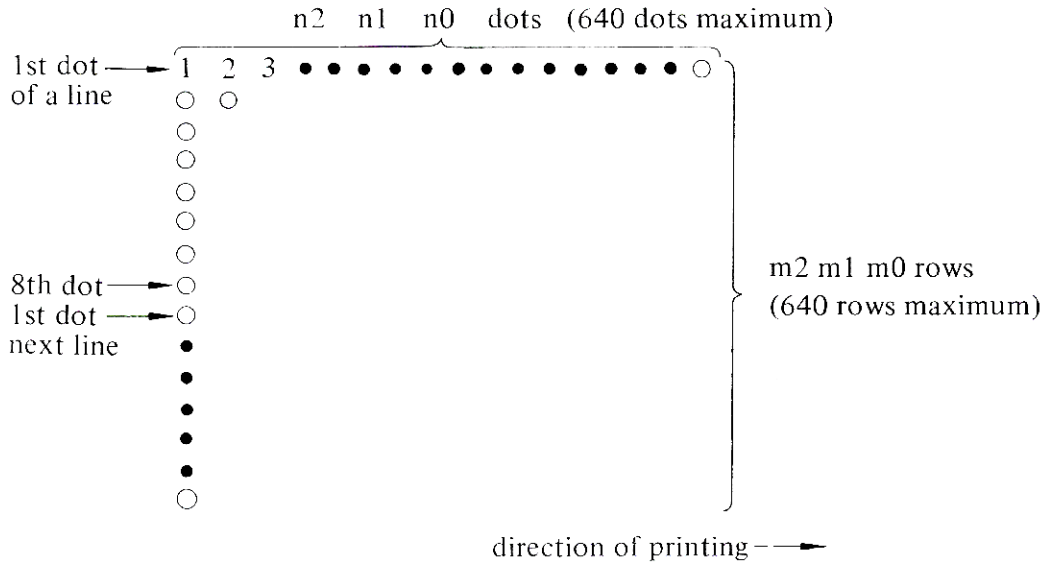

ESC C specifies the raster scan (RGB) mode, followed by n2n1n0 and m2m1m0 which specify the number of dots to be printed in the horizontal direction and the number of dots to be printed in the vertical direction. This is then followed by N x M bytes of data (N = n2n1n0 and M = m2m1m0). Both N and M must be within a range of 001 and 640. Each dot is represented by one byte which specifies the color for that dot as follows.

| D8 | D7 | D6 | D5 | D4 | D3 | D2 | D1 |              |
|----|----|----|----|----|----|----|----|--------------|
| X  | X  | X  | X  | X  | B  | G  | R  | X = not used |

RGB or Red, Green and Blue are the primary colors that make up white light. This corresponds to the three colors that are used to make up the color for output from personal computers to color video monitors. There are eight RGB color combinations shown as follows with the corresponding color that is printed:

| B | G | R | COLOR PRINTED  | REMARKS                       |
|---|---|---|----------------|-------------------------------|
| 0 | 0 | 0 | white or black | Depends on DIP switch No. 1   |
| 0 | 0 | 1 | red            | Mixture of yellow and magenta |
| 0 | 1 | 0 | green          | Mixture of yellow and cyan    |
| 0 | 1 | 1 | yellow         |                               |
| 1 | 0 | 0 | purple         | Mixture of cyan and magenta   |
| 1 | 0 | 1 | magenta        | (reddish purple)              |
| 1 | 1 | 0 | cyan           | (light blue)                  |
| 1 | 1 | 1 | black or white | Depends on DIP switch No. 1   |

Note: White means that the printer prints nothing.

```

10 REM RASTER SCAN RGB EXAMPLE
20 FOR I=0 TO 6
30 LPRINT
40 LPRINT CHR$(27)+"C050016";:REM
   '050'=HORIZONTAL DOTS, '016'=
   VERTICAL DOTS
50 FOR J=1 TO 800:LPRINT CHR$(I);:NEXT
   J
60 NEXT I

```

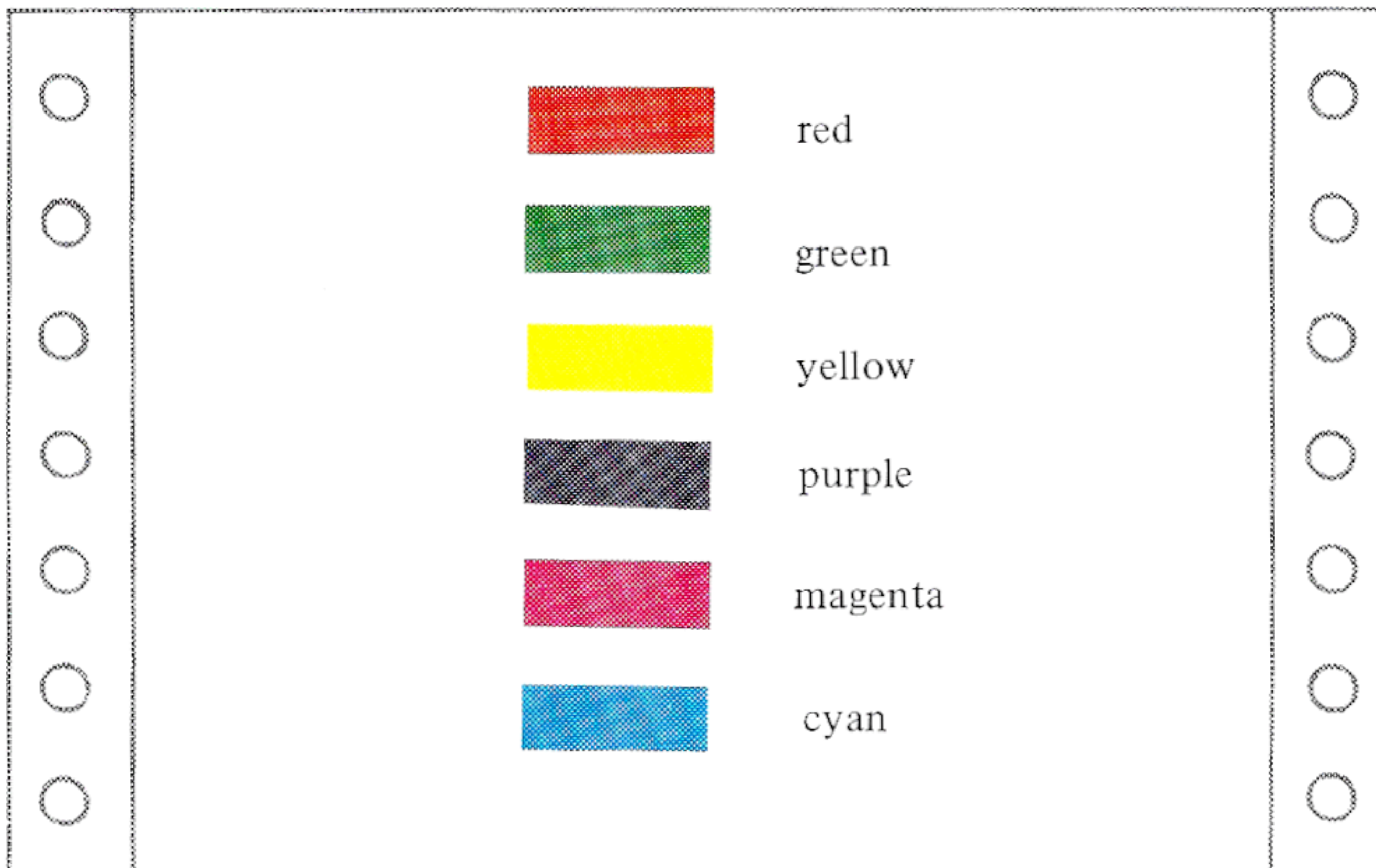



**Print Hammer Raster Scan Graphics** ESC P n2n1n0 m2m1m0 data  
 (1B)(50) n2n1n0 m2m1m0 data Hex  
 (27)(80) n2n1n0 m2m1m0 data Decimal

---

Another means of input that allows the color for each dot to be individually specified is the ‘print hammer’ correspondence method. It is a raster scan method similar to the RGB method except that the color code is a correspondence to each of the four hammers (and the colors they reproduce).

ESC P specifies the ‘print hammer’ mode. This is followed by n2n1n0, which is the number of columns, and m2m1m0, the number of rows of data that will be input. This is then followed by the exact number of data specified in n2n1n0 and m2m1m0. Each dot is represented by one byte with the color being selected as shown below:

|    |    |    |    |    |    |    |    |
|----|----|----|----|----|----|----|----|
| D8 | D7 | D6 | D5 | D4 | D3 | D2 | D1 |
| X  | X  | X  | X  | P4 | P3 | P2 | P1 |

P4, P3, P2, P1 corresponds to the colors produced by the individual hammers. P1 = yellow, P2 = magenta, P3 = cyan, P4 = black. There are eight combinations of P1, P2, P3, and P4. These are listed in the table below:

| P4 | P3 | P2 | P1 | COLOR PRINTED | REMARKS                     |
|----|----|----|----|---------------|-----------------------------|
| 0  | 0  | 0  | 0  | white         | The printer prints nothing. |
| 0  | 0  | 0  | 1  | yellow        |                             |
| 0  | 0  | 1  | 0  | magenta       | (reddish purple)            |
| 0  | 0  | 1  | 1  | red           |                             |
| 0  | 1  | 0  | 0  | cyan          | (light blue)                |
| 0  | 1  | 0  | 1  | green         |                             |
| 0  | 1  | 1  | 0  | purple        |                             |
| 1  | 0  | 0  | 0  | black         |                             |

Note: Combinations other than the above are printed as black.

## Print Hammer Raster Scan Graphics Example

---

```
10 REM PRINT-HAMMER EXAMPLE
20 FOR I=0 TO 6
30 LPRINT
40 LPRINT CHR$(27)+"P050016";:
    REM '050' = HORIZONTAL DOTS,
    '016' = VERTICAL DOTS
50 FOR J=1 TO 800
60 LPRINT CHR$(I);
70 NEXT J
80 NEXT I
90 LPRINT
```

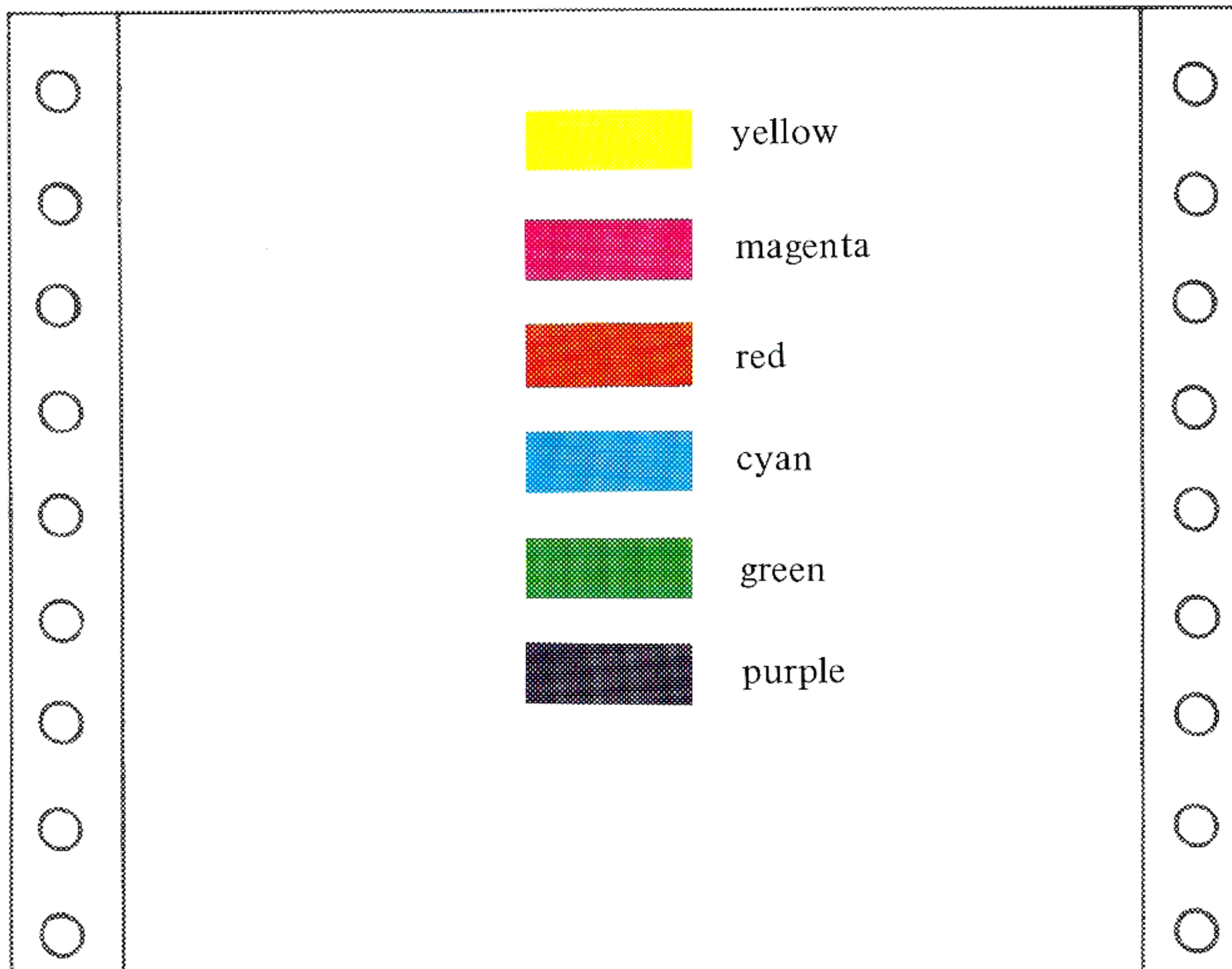



## Single Pass Graphics Printing

ESC D

(1B)(44) Hex

(27)(68) Decimal

---

This command specifies that all graphics will be printed in the single pass mode. When the power is turned on or when an INITIAL signal is sent from the computer, this mode is automatically selected. Most of your normal graphics should be printed in this mode. This mode is cleared only by an ESC E control code.

```
10 REM SINGLE PASS GRAPHICS PRINTING
20 LPRINT CHR$(27);CHR$(68):REM
    SELECT SINGLE PASS GRAPHICS
```

NOTE: No example is provided. Use of the Apple Screen Output software or the optional Apple PICS interface will demonstrate its use more fully. You may wish to try running this program, then typing in the RGB raster scan graphics example.

This command specifies printing graphics in two-passes of the printhead. The two-pass mode is recommended when printing large graphics pictures that print every dot (color fill). This gives the ribbon time to re-ink and also extends the life of the ribbon.

```
10 REM DOUBLE-PASS GRAPHICS MODE
20 LPRINT CHR$(27);CHR$(69):REM
    SELECT DOUBLE PASS MODE
```

NOTE: No example is provided. Use of the Apple Screen Output software or the optional Apple PICS interface will demonstrate its use more fully. You may wish to try running this program, then typing in the RGB raster scan graphics example.



## Advanced Graphics Example

---

The Transtar 315 can be programmed to print beautiful color pictures. It will individually print 640 horizontal dots across the page. The following illustrates how to develop and print a graphic symbol. Assume we wish to create a “spades” character. First you need to plot the character on graph paper. Remember that on a single pass of the printhead 8 vertical dot columns may be printed.

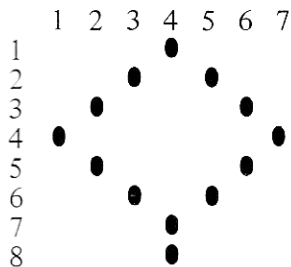

Next, convert the columns to binary digits. Read columns 1 thru 7 from the bottom up.

|          | A       | B    |
|----------|---------|------|
| Column 1 | -- 0000 | 1000 |
| 2        | -- 0001 | 0100 |
| 3        | -- 0010 | 0010 |
| 4        | -- 1100 | 0001 |
| 5        | -- 0010 | 0010 |
| 6        | -- 0001 | 0100 |
| 7        | -- 0000 | 1000 |

Now using Appendix B, the ASCII code table, convert the binary numbers to their decimal equivalent. Column A refers to the top column and Column B refers to the rows. For column 1, find '0000', then look down the side rows to find '1000'. This value is 8.

|          |         |      |       |
|----------|---------|------|-------|
| Column 1 | -- 0000 | 1000 | = 8   |
| 2        | -- 0001 | 0100 | = 20  |
| 3        | -- 0010 | 0010 | = 34  |
| 4        | -- 1100 | 0001 | = 193 |
| 5        | -- 0010 | 0010 | = 34  |
| 6        | -- 0001 | 0100 | = 20  |
| 7        | -- 0000 | 1000 | = 8   |

Now you are ready to begin programming. Let's also make use of character position (POS n2n1n0) and color selection (DC4+n).

## Advanced Programming Example continued

```
10 REM ADVANCED PROGRAMMING EXAMPLE
20 FOR K = 10 TO 20: REM PRINT STARTI
   NG IN COLUMN 10 TO 20
30 L PRINT CHR$ (16) + "0" + STR$ (K)
   ;: REM CHARACTER POSITION
40 IF CL = 7 THEN CL = 0: REM INCREME
   NT COLOR
50 L PRINT CHR$ (20) + CHR$ (CL);: REM
   SET COLOR
60 L PRINT CHR$ (27) + "K007" + CHR$
   (8) + CHR$ (20) + CHR$ (34) + CHR$
   (193) + CHR$ (34) + CHR$ (20) +
   CHR$ (8)
70 CL = CL + 1: REM INCREMENT COLOR
80 NEXT K
90 END
```

In line 60, CHR\$(27)+"K", sets the graphics mode. The "007" is the number of graphics data that will follow. The "CHR\$(8)+CHR\$(20)+..." are seven graphics data calculated earlier.

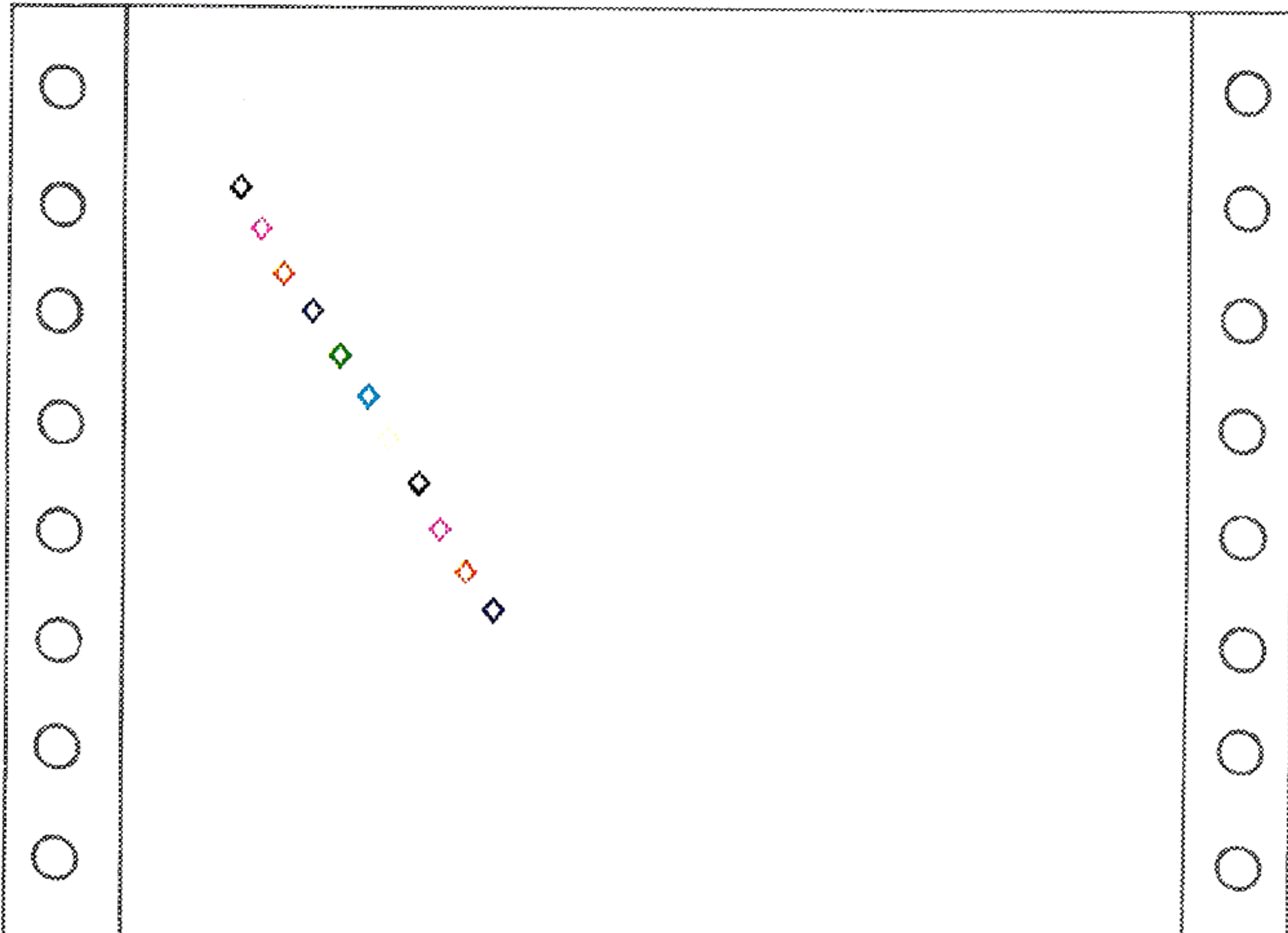



## Getting Fancy . . . Highlighting Example

You have probably at times used a blue or yellow highlighter to accentuate a portion of a document. The Transtar 315 can be programmed to highlight text in different colors. It requires some calculations as to how many dot columns are required to highlight a word. You will want to print the lighter color (highlight color) first, then the darker text characters.

```
10 REM HIGHLIGHTING EXAMPLE
20 L PRINT CHR$ (16) + "020";: REM MO
   VE TO THE 20TH CHARACTER POSITION
30 L PRINT CHR$ (20) + CHR$ (5);: REM
   SELECT CYAN
40 L PRINT CHR$ (28) + CHR$ (90) + CHR$
   (255);: REM PRINT 90 COLUMNS OF Y
   ELLOW
50 L PRINT CHR$ (20) + CHR$ (0);: REM
   SELECT BLACK
60 L PRINT CHR$ (16) + "020";: REM MO
   VE TO THE 20TH CHARACTER POSITION
70 L PRINT "HIGHLIGHTED"
80 END
```

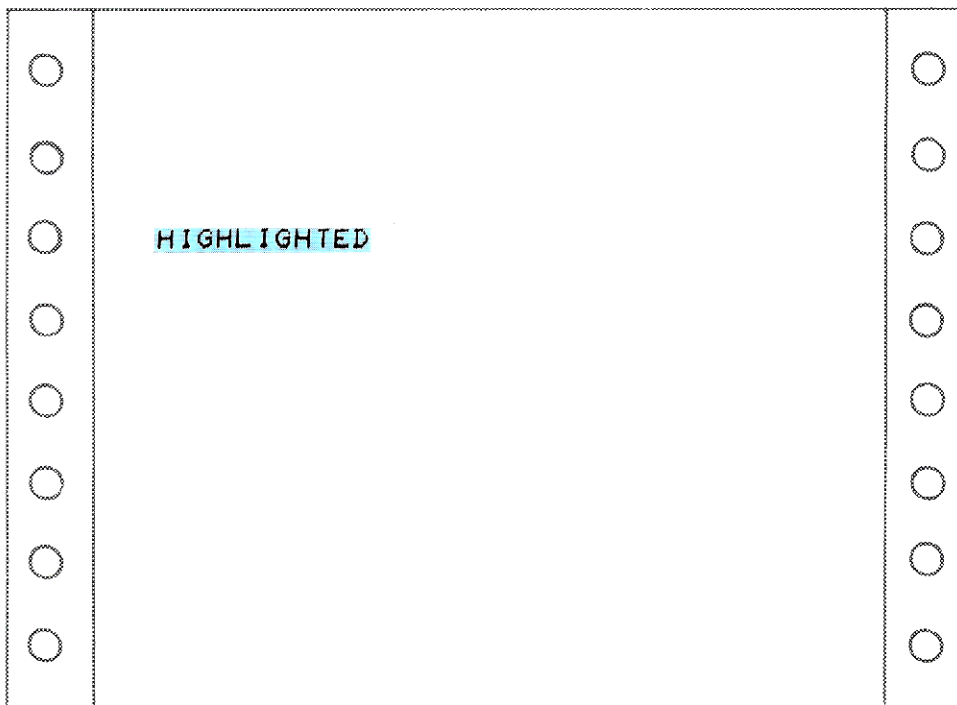



## Appendix **A**

### Using the Optional PICS Interface with the Apple II/Ile or Franklin Computers

The PICS Interface is the first interface specifically designed to activate a graphics COPY button on the T315 printer. This allows you to print any graphics image, either high or low resolution, from the Apple II/Ile or Franklin computers to the T315 without the use of utility software or imbedded codes. The PICS card is software independent, allowing you to dump graphics screens by simply pressing the COPY button.

#### Installing the PICS Interface

If you have 64K of memory in your Apple or II Plus or an Extended 80-column card in your Apple Ile, you will need to switch either of the two dip switches to the ON position. To determine this, check to see if you have a language card or RAM card in slot #0 of the Apple. If you own an Apple Ile without the Extended 80-column card, both dip switches should be in the ON position. Franklin computer users must turn either of the dip switches OFF.

##### 1. Inserting the PICS Interface in your Computer

The PICS Interface is designed to work in Apple's or Franklin's slot number 1. Before installation, make sure the power to your Apple is turned **OFF**. Failure to do so when installing the PICS card could result in damage to your computer and to the interface card. Gently open the top cover and insert the PICS card into slot #1. You may have to rock it into place. Slot #1 on the Apple II or II Plus is the second slot from the left. On the Apple Ile, slot #1 is the first slot on the back left.

##### 2. Plugging in the Cable

Looking at the PICS card, match the triangle on the connector receptacle with the triangle on the connector (red wire on the ribbon cable will be toward the dip switch side of the card), then press in the connector firmly. Plug the amphenol connector (36 pin) into the printer receptacle.

##### 3. Turn the Transtar 315 ON

Assuming you have set up the T315 according to the installation instructions, load paper and turn the power switch on.

##### 4. Turn the Apple/II Plus or Ile or Franklin ON

Before turning the computer power on, you need to be aware that the PICS interface must be 'initialized.' This is accomplished by accessing the slot with a PR #1. Once the card is initialized, the copy function will operate. A PR #1 may be inserted into your disk programs for automatic initialization of the PICS card. Insert your DOS 3.3 System Master disk into disk drive #1 and turn the computer power on. Your DOS master will 'boot-up' and return with a square bracket prompt. Type in ]PR #1 then depress the RETURN key.



Follow this with a ]PR #0 and RETURN. Start by running any graphics demo program on the System Master. A good demo is Brian's Theme. Type in ]RUN BRIAN'S THEME then depress the RETURN key. Whenever you wish to print the graphics image, depress the COPY button on the T315, then depress the SPACE BAR. The program will stop execution until the printer has completed printing the picture.

## Changing the PICS Option

Upon depressing the COPY button on the printer, you may change any of the pre-set options. The normal options are:

- White-on-screen prints black on the printer
- High resolution Page 1
- Left-justified
- Dot-to-dot printing
- 1-pass color printing
- Standard Horizontal and Vertical Size
- 24 lines

These can easily be changed to fit your application program. After depressing the COPY button, the computer waits for a letter sequence. If any other letter other than the ones listed below are depressed, the printer starts printing. All options are toggles on-or-off by depressing the appropriate letters. The default selections are in bold-face.

| Letter | Option   |
|--------|--|
| D      | Dot Pattern ( <b>Dot-per-dot</b> or Fill)            |
| H      | Horizontal Size ( <b>Normal</b> or Expanded)         |
| V      | Vertical Size ( <b>Normal</b> or Expanded)           |
| J      | Location ( <b>Left Justified</b> or Centered)        |
| I      | Inversion ( <b>White-to-black</b> or Black-to-Black) |
| P      | High-resolution Page ( <b>Page 1</b> or Page 2)      |
| R      | Resolution ( <b>High</b> or Low)                     |
| K      | Color Mode ( <b>Color</b> or Black-and-White only)   |
| T      | Print Mode ( <b>1-pass</b> or 2-pass)                |
| L      | Graphic lines ( <b>24</b> or 20)                     |

With the same example program running, depress the COPY button and key in the letters KJ, then depress the SPACE BAR. Notice that the picture will be printed in black-and-white and centered.

If you depress the COPY button, then the KJ letters again, the picture will again appear left justified and in color.

## Printing Pictures of Application or Entertainment Programs

Turn the printer on, then turn the power to your computer on **without** a disk in your drive. Holding the CTRL key down, depress the RESET key to exit to BASIC. Type in]PR #1 then depress the RETURN key followed by a ]PR #0 and the RETURN key. Insert your application program in disk drive #1 then type in]PR #6 followed with a RETURN. Anytime a graphics picture is on the screen, you may depress the COPY switch, type the option letter sequence, and press the RETURN or SPACE BAR key.

## Compatibility

The PICS Interface is compatible with software programs that do not use the 6502 microprocessor interrupts. Apple Pascal is compatible with the PICS card. However, because CP/M uses the Z80 microprocessor, it is not compatible.

### BOTH Dip Switches

|                      |     |
|----------------------|-----|
| Apple II/II Plus 48K | ON  |
| Apple II/II Plus 64K | OFF |
| Apple IIe 64K        | ON  |
| Apple IIe 128K       | OFF |
| Franklin             | OFF |

Certain entertainment software requires the removal of the language card for proper operation. See the booklet provided with the PICS interface card for further instructions on printing from the immediate mode.



# Appendix B

## ASCII Code Table

| Upper Bit | Hex. | 0      | 1    | 2    | 3    | 4    | 5    | 6    | 7    | 8    | 9    | A    | B    | C    | D    | E    | F    |      |
|-----------|------|--------|------|------|------|------|------|------|------|------|------|------|------|------|------|------|------|------|
| Lower Bit | Hex. | Binary | 0000 | 0001 | 0010 | 0011 | 0100 | 0101 | 0110 | 0111 | 1000 | 1001 | 1010 | 1011 | 1100 | 1101 | 1110 | 1111 |
| 0         | 0000 | 0      | POS  | SP   | 0    | €    | P    | ‘    | p    |      |      | à    | À    | P    | p    |      |      |      |
| 1         | 0001 | 1      | 16   | 32   | 48   | 64   | 80   | 96   | 112  | 128  | 144  | 160  | 176  | 192  | 208  | 224  | 240  |      |
| 2         | 0010 | 2      | 17   | 33   | 49   | 65   | 81   | 97   | 113  | 129  | 145  | 161  | 177  | 193  | 209  | 225  | 241  |      |
| 3         | 0011 | 3      | 18   | 34   | 50   | 66   | 82   | 98   | 114  | 130  | 146  | 162  | 178  | 194  | 210  | 226  | 242  |      |
| 4         | 0100 | 4      | 19   | 35   | 51   | 67   | 83   | 99   | 115  | 131  | 147  | 163  | 179  | 195  | 211  | 227  | 243  |      |
| 5         | 0101 | 5      | DC4  | S    | 4    | D    | T    | d    | t    |      |      | é    | Ë    | T    | t    |      |      |      |
| 6         | 0110 | 6      | 21   | 37   | 53   | 69   | 85   | 101  | 117  | 133  | 149  | 165  | 181  | 197  | 213  | 229  | 245  |      |
| 7         | 0111 | 7      | 22   | 38   | 54   | 70   | 86   | 102  | 118  | 134  | 150  | 166  | 182  | 198  | 214  | 230  | 246  |      |
| 8         | 1000 | 8      | 23   | 39   | 55   | 71   | 87   | 103  | 119  | 135  | 151  | 167  | 183  | 199  | 215  | 231  | 247  |      |
| 9         | 1001 | 9      | 24   | 40   | 56   | 72   | 88   | 104  | 120  | 136  | 152  | 168  | 184  | 200  | 216  | 232  | 248  |      |
| A         | 1010 | 10     | 25   | 41   | 57   | 73   | 89   | 105  | 121  | 137  | 153  | 169  | 185  | 201  | 217  | 233  | 249  |      |
| B         | 1011 | 11     | 26   | 42   | 58   | 74   | 90   | 106  | 122  | 138  | 154  | 170  | 186  | 202  | 218  | 234  | 250  |      |
| C         | 1100 | 12     | 27   | 43   | 59   | 75   | 91   | 107  | 123  | 139  | 155  | 171  | 187  | 203  | 219  | 235  | 251  |      |
| D         | 1101 | 13     | 28   | 44   | 60   | 76   | 92   | 108  | 124  | 140  | 156  | 172  | 188  | 204  | 220  | 236  | 252  |      |
| E         | 1110 | 14     | 29   | 45   | 61   | 77   | 93   | 109  | 125  | 141  | 157  | 173  | 189  | 205  | 221  | 237  | 253  |      |
| F         | 1111 | 15     | 30   | 46   | 62   | 78   | 94   | 110  | 126  | 142  | 158  | 174  | 190  | 206  | 222  | 238  | 254  |      |
|           |      |        | 31   | 47   | 63   | 79   | 95   | 111  | 127  | 143  | 159  | 175  | 191  | 207  | 223  | 239  | 255  |      |

## Appendix C

### Troubleshooting Guide

Use the table below to diagnose any problems that may occur. If you cannot solve the problem, try to decide which part of your system is not working properly and then consult your dealer.

| PROBLEM   | Cause and Remedy   |
|---|--|
| The printer does not print.<br>The POWER lamp does not light.                     | 1) Power is not getting to the printer<br>· Check the power cord and power switch.<br>2) The fuse may be blown<br>· Replace it with exactly the same type of fuse.   |
| The printer does not print.<br>The POWER lamp is lit.                             | 1) The connection to the computer is not correct.<br>· Check to make sure that the cable connecting the printer and computer is correctly connected.<br>2) The ribbon cassette is not properly installed.<br>· Properly install the ribbon cassette.   |
| The printer is operating properly but the paper is not feeding through, properly. | 1) The paper is jammed in the printer.<br>· Remove the paper and reinsert it properly.   |
| The print is light or smeared.  | 1) The printhead position is not correct<br>· Move the head adjustment lever to match the type of paper being used.<br>2) The ribbon cassette is not properly installed.<br>· Properly install the cassette.<br>3) The transfer of ink from an ink cartridge to the ribbon is too much since the color is not used to print.<br>· Push the cartridge lever towards the outside of the cassette as shown in Figure 7. |



**PROBLEM****Cause and Remedy**

---

The print is light or smeared.

- 4) There is no ink in one of the ink cartridges.
    - Replace the old ink cartridge with a new ink cartridge.
  - 5) The ribbon has been used too long.
    - Replace the old ribbon cassette with a new one.
- 

The POWER lamp is blinking

- 1) An ERROR condition has occurred due to the detection of abnormal timing in a sensor.
  - Turn power off and then back on again or input the INITIAL signal.

## Appendix **D**

### Color Tips

The Transtar 315 color printer is designed so that lighter colors are printed before darker colors in a single pass. The color ribbon has four bands, yellow, magenta, cyan, and black. It is recommended that printing lighter colors on top of darker colors be avoided to prevent staining of the lighter colored bands on the ribbon. Continuous printing of lighter colors on top of darker colors will contaminate the lighter band on the ribbon. If this occurs, continuous printing and re-inking in the proper sequence of light color then dark color print will improve the color on the stained ribbon. In normal operation, the sequence of printing dark colors, then light colors should not occur. Only under special software programming can this be accomplished.



## Appendix E

### Using the PICS Card Under CP/M

To use the PICS card under CP/M, you must modify the operating system for proper interaction. The PICS card COPY feature will not function for graphics under CP/M because the CP/M card uses the Z-80 microprocessor chip.

This modification need be done only once. Keep the disk as your new System Master and use it whenever you copy the CP/M system onto a new diskette with the COPY/S command.

Here is the method for modifying CP/M for use with the PICS interface card.

1. Copy your CP/M System Master disk onto another working disk as explained in the Z-80 card manual.
2. Put this working disk in drive A and boot it up.
3. Enter DDT by typing: **DDT (RETURN)**
4. Enter the data needed to patch the CP/M I/O section by typing:  
**S100 (RETURN)**
5. DDT will prompt with:  
**0100 01**  
which means it is ready to accept the value to be placed at memory location 100. Enter all of the values in Table 1 by typing each value followed by a (RETURN).

| ADDRESS | DATA |    |    |    |    |    |    |    |
|---------|------|----|----|----|----|----|----|----|
| 0100    | 01   | 00 | F2 | 70 | 00 | 01 | 0A | 00 |
| 0108    | F2   | C3 | 03 | F2 | 21 | 00 | C1 | 3E |
| 0110    | 3D   | 32 | 01 | F2 | 79 | 32 | 5E | F2 |
| 0118    | 3E   | 09 | 32 | 45 | F0 | CD | 56 | F2 |
| 0120    | 0E   | 19 | CD | 3D | F2 | 0E | 19 | CD |
| 0128    | 3D   | F2 | 0E | 38 | CD | 3D | F2 | 0E |
| 0130    | 30   | CD | 3D | F2 | 0E | 4E | CD | 3D |
| 0138    | F2   | 0E | 0D | CD | 3D | F2 | 3A | 5E |
| 0140    | F2   | 4F | CD | 3D | F2 | C9 | 3E | FF |
| 0148    | 32   | 08 | F0 | 79 | FE | 0A | C2 | 4A |
| 0150    | F2   | 3E | 00 | EE | 80 | 32 | 45 | F0 |
| 0158    | 21   | 05 | C1 | CD | 56 | F2 | C9 | 22 |
| 0160    | D0   | F3 | 2A | DE | F3 | 77 | C9 |    |

TABLE 1 CP/M I/O PATCH DATA

## Appendix **E** continued

5. To end input, type:  
**(RETURN)**
6. Display the data by typing:  
**D100, 167 (RETURN)**
7. Check each data value to be sure that it is correct.
8. If you find an error, fix it by using the S command.  
Type: **Saaa**  
where aaa is the address of the error.  
DDT will prompt with:  
**aaa xx**  
where aaa is the address you entered, and xx is the incorrect data.  
Type in the correct value and depress **(RETURN)**.  
Type:  
**(RETURN)**  
to end correcting errors.  
Go back to step 7 to check your corrections.
9. When everything is correct, exit from DDT by typing:  
**GO (RETURN)**
10. Save the file that you have just created by typing:  
**SAVE 1 PATCH.COM (RETURN)**
11. Run the program to reconfigure your I/O by typing:  
**MBASIC CONFIGIO (RETURN)**
12. The computer will prompt:  
**Can your Apple Display Lower Case (Y/N)-**
13. Type in Y if you have a lower case adapter, N if you do not.
14. The program will then ask you to choose an I/O Configuration Program activity. After the word **Select**, Type:  
**3**
15. You will be prompted: **OBJECT FILE NAME**  
Type in: **PATCH.COM (RETURN)**
16. You will again be asked to **Select** an activity. This time type:  
**4**
17. The computer will prompt:  
**READ OR WRITE (R/W)**  
Type:  
**W**



## Appendix E continued

18. The computer will prompt:

Destination drive (A:-F:)

Type:

A:

The modified I/O routines are now a part of the CP/M system on this disk. Because CP/M treats Control I as a TAB function, this patch changes the control character to Control Y instead of the usual Control I.

## Appendix **F**

### Warranty

#### **Warranty Statement**

The Transtar 315 is warranted against defects in materials and workmanship for a period of six months from the date of sale to the end-user, provided that the sale to the end-user is made within six months of the date of shipment from Transtar. Transtar's obligation under this Limited Warranty is limited to repairing or replacing, at Transtar's option, any machine or parts returned to Transtar or its designated Service Centers within the warranty period, subject to the conditions stated below.

#### **Exclusions**

The Limited Warranty provided by Transtar does not cover:

- 1) Damage due to shipping or handling of the product.
- 2) Damage due to misuse or abuse of the product, either mechanical or electrical.
- 3) Misoperation due to unauthorized repair or modification.
- 4) Supplies (ribbons) or preventative maintenance.
- 5) Consequential damages of any sort.

This Limited Warranty is in lieu of all other warranties, whether expressed or implied, and imposes no obligation on Transtar concerning merchantability or fitness for a particular use.

#### **Warranty Service Procedures**

If service is required, please contact the Authorized Service Center nearest you.



## Glossary

**Bit** -- a binary digit (a 1 or 0 in binary notation).

**Buffer** -- a RAM chip that temporarily holds data received from the host computer until the printer can actually print them. Usually works on a first-in, first out (FIFO) sequence.

**Byte** -- a group of adjacent binary digits (bits) operated on by the computer as a unit. The most common size byte contains 8 bits.

**Carriage return** -- the movement of the printhead to the starting position of the next line (usually position '0').

**Control code** -- information sent to the printer by the computer to alter a print function.

**Control signal** -- signals between the computer and printer that regulate the operation of the printer.

**CPI** -- characters per inch. Ten cpi type are referred to as Pica; 12 cpi refers to elite.

**CPU** -- central processing unit. The central processor that controls all of the printer's functions.

**ESC sequence** -- a software code, ESC, followed by a sequence that is sent to the printer to alter the special print functions.

**Form feed** -- the movement of paper up a set amount of lines, usually to the next page or Top of Form.

**Friction feed** -- a mechanism for moving paper around the platen by pressing it between two rubber rollers. Similar to the function of a typewriter.

**LPI** -- lines per inch. The number of printable lines in a vertical inch.

**Line feed** -- the movement of paper one line or the amount of space set by ESC T nln0.

**Parallel interface** -- a type of interface in which all bits of data in a given byte are transmitted simultaneously, using a separate data line for each bit.

**Serial interface** -- a type of interface in which bits are transmitted sequentially (one after another), rather than all at one time as in parallel interfacing.

**Tractor feed** -- a mechanism that pulls continuous form paper through the printer in a controlled manner, minimizing slippage and misalignment. The paper is pulled through the tractors by means of guide holes on both edges.

# Index

---

- 6 lines per inch spacing 33
- 8 lines per inch spacing 34
  
- ACK 21
- Advanced Graphics Example 52,53
- Appendix A 55
- Appendix B 58
- Appendix C 59
- Appendix D 61
- Appendix E 62
- Appendix F 65
- Apple II/IIe 2,15,17,24
- Apple Screen Copy Program 51
- ASCII Code Table 41,58
- Automatic Printing Function 15
- BUSY 21
  
- Caring for Your Printer 16
- Carriage Return 27
- Cassette Type 3
- Centronics Parallel 2,18
- Changing the PICS option 56
- Character Position 52
- Clear Buffer 31
- Color Selection 52
- Color Tips 61
- Configuring your printer 17
- Continuous Forms 11
- Converting to Apple II Format 24
- Copy Button 2,17
- Copy Lamp 6
- Copy Switch 5
- CP/M 62
  
- Dip Switch 22,27
- Dip Switch Settings 22,27
- Dot Graphics 41,43
- Double Pass Graphics Printing 51
- Double Width Printing 30
  
- Electrical Conditions 20
- Error 21
- Error Conditions 15
- ESC A 25
- ESC B 25
- ESC D 26
- ESC E 26
- ESC G 25
- ESC K 26
- ESC K n2n1n0 26
- ESC N 25
- ESC P n2n1n0m2m1m0 26
- ESC POS nHnL 25
- ESC R CD 26
- ESC T n1n0 25
- ESC Z (00)H n 25
- ESC Z n 25
- External Dimensions 3
  
- FCC Notice ii
- FF 29
- Form Feed 29
- Form Feed Switch 5
- FS n GD 26
  
- General Specifications 3
  
- Head Adjustment Lever 14
- Head Position Adjustment 14
- Humidity 3
  
- Individual Re-inking Cartridge 3
- INITIAL 15,20,21,29,30,33,39,44,50
- Ink Cartridge Replacement 10
- Ink Cartridge Sets 3
- Ink Colors 3
- Ink Ribbon Removal 8
- Ink Ribbon Specifications 3
- Installing Ink Ribbon 8
- Interfacing 17
- Introduction 1
  
- LF 15,28
- Line Feed 15,28
- Line Feed Speed 3
- Line Feed Switch 5
- Line Spacing 3
- Loading the Paper 11



Maintenance 16  
 MBasic 23  
  
 Number of Copies 3  
  
 Operating Environment 3  
 Operator Indicators 5  
 Operator Switches 5  
  
 Page Length by Number of Lines 37  
 Page Length in Inches 38  
 Paper Empty 6,13  
 Paper Empty Lamp 5  
 Paper Feed Direction 3  
 Paper Feed Method 3  
 Paper Feed Specifications 3  
 Parts of the Printer 4  
 PICS Interface 2,5,17,51,62  
 POS n2n1n0 25  
 Power Consumption 3  
 Power Lamp 5  
 Power Supply 3  
 Power Switch 5  
 Print Hammer Raster Scan Graphics 48  
 Print Position by Character 35  
 Print Position by Dot Column 36  
 Printing Colors 3  
 Printing Direction 3  
 Printing Method 3  
 Printing Speed 3  
 Programming Code Summary 25  
 Programming Codes 26  
 Programming Your Printer 23  
  
 RGB Raster Scan Graphics 47  
 Removing Ink Ribbon 8  
 Repeated Character Printing 45  
 Repeated Printing of Graphics 43  
  
 Selecting 10 cpi Print 25  
 Selecting 13.3 cpi Print 25  
 Selecting Colors 44  
 Self Test 15  
 Serial Interface Board 2  
 Setting Variable Line Feed Spacing 32  
  
 SI 25  
 Signal Cable Length 21  
 Single Pass Printing 50  
 Single Sheets of Paper 13  
 SO 25  
 Stop Switch 5,6  
 Strobe 20,21  
  
 Temperature 3  
 Timing Chart 21  
 Troubleshooting Guide 59  
  
 Using the Optional PICS Card 55  
 Using the PICS Card under CP/M 62  
  
 Warranty 65  
 Weight 3

# Transtar 315 Printer

## User Comment Form

Name \_\_\_\_\_ Phone \_\_\_\_\_

Address \_\_\_\_\_

City, State \_\_\_\_\_ Zip \_\_\_\_\_

\*Printer Serial No. \_\_\_\_\_ Date Purchased \_\_\_\_\_

Dealer Name \_\_\_\_\_

1. Is the Operator's Manual easy to use and understand?      Yes      No

Comment \_\_\_\_\_

2. Are the illustrations clear and helpful?      Yes      No

Comment \_\_\_\_\_

3. Please note any errors detected in the manual:

Page \_\_\_\_\_ Error \_\_\_\_\_

Page \_\_\_\_\_ Error \_\_\_\_\_

4. What computer is this printer being used with?

Manufacturer \_\_\_\_\_ Model \_\_\_\_\_

5. What software is being used?

Manufacturer \_\_\_\_\_ Package \_\_\_\_\_

Manufacturer \_\_\_\_\_ Package \_\_\_\_\_

6. Please comment on the printer itself and any suggestions you have for additional features, etc.

\_\_\_\_\_

\_\_\_\_\_

Thank you for your feedback. If you have included your name and address, a copy of any future version of the manual or programming aids will be sent to you at no charge.

\*Serial number is located on the rear of printer on the right of base.

Return this form to: **Transtar** Box C-96975, Bellevue, Washington 98009



## FCC Notice

This equipment generates and uses radio frequency energy and if not installed and used properly (that is, in strict accordance with the manufacturer's instructions) may cause interference to radio and television reception. It has been type-tested and found to comply with the limits for a Class B computing device in accordance with the specifications in Subpart J of Part 15 of FCC Rules, which are designed to provide reasonable protection against such interference in a typical installation. However, there is no guarantee that interference will not occur in a particular installation. If this equipment does cause interference to radio or television reception, which can be determined by turning the equipment off and on, the user is encouraged to try one of the following measures:

- Reorient the receiving antenna
- Relocate the printer with respect to the receiver
- Move the printer away from the receiver
- Plug the printer into a different outlet so that the printer and receiver are on different branch circuits

If necessary, the user should consult the dealer or an experienced radio/television technician for additional suggestions. The user may find the following booklet prepared by the Federal Communications Commission helpful: "How to Identify and Resolve Radio-TV Interference Problems." It is available from the U.S. Government Printing Office, Washington, DC 20402, Stock No. 004-000-00345-4.

**Transtar**  
A **Vivitar** Computer Product

2100 116th Avenue N.E.  
P.O. Box C-96975  
Bellevue, Washington 98009

Printed in the U.S.A.  
V2.0 7-83